

PIEZA MÁS GRANDE
 BIGGEST PART
 LA PLUS GRANDE PIECE
 1440 x 1230 mm

PIEZA MÁS PESADA
 HEAVIEST PART
 LA PIECE LA PLUS LOURDE
 41 Kg

ÁREA LIBRE DE OBSTÁCULOS
 AREA FREE FROM OBSTACLES
 ZONE LIBRE D'OBSTACLES
 A+B

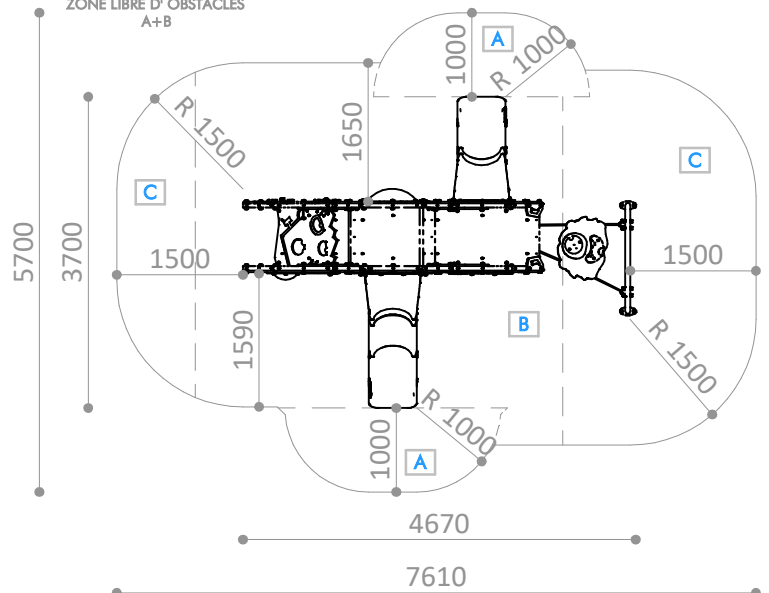

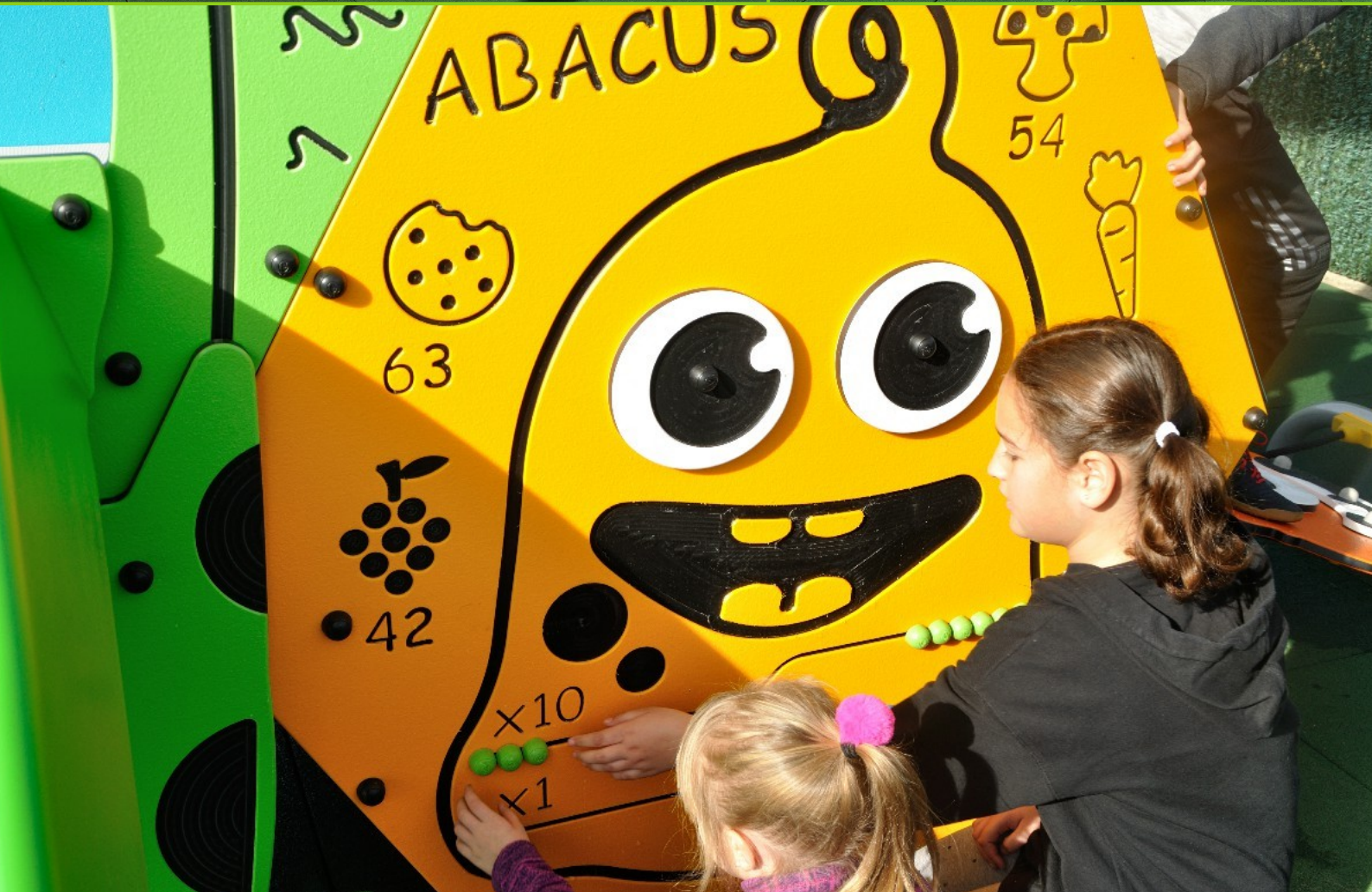
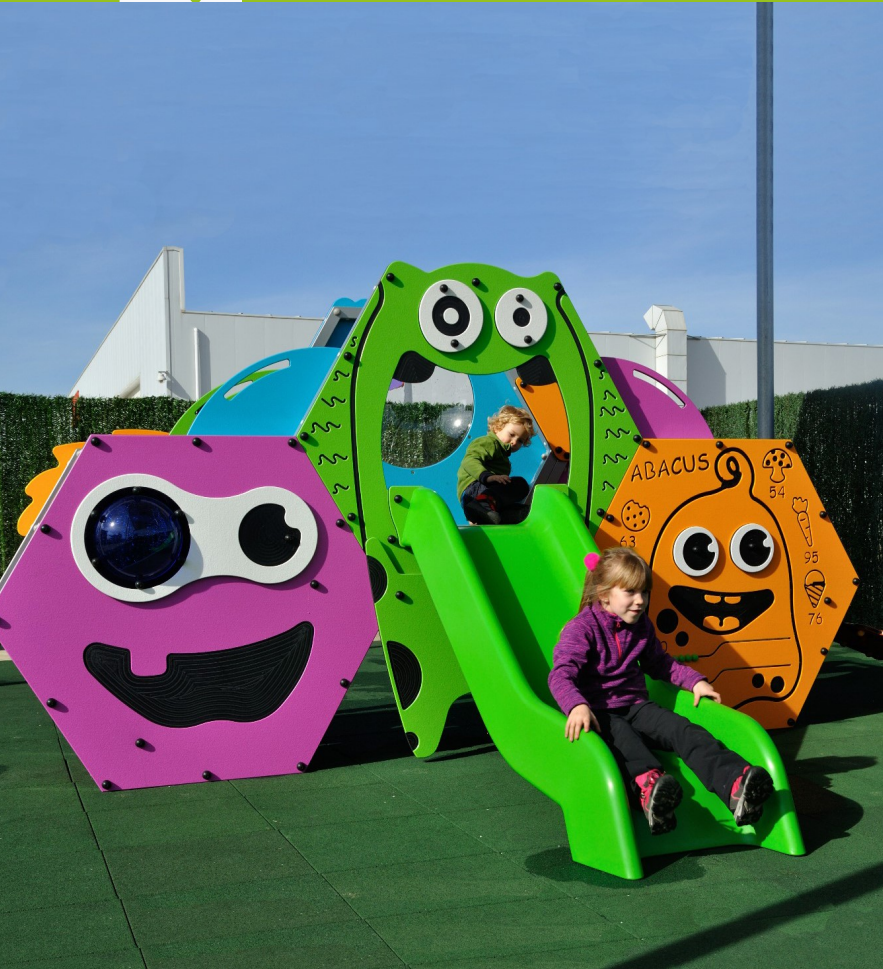





Descripción/ Multijuego formado por sistema patentado de módulos hexagonales apilados, formando una estructura celular de tipo 'Panal de abejas', con temática "SPOOKY". Diferentes niveles de juego 0/ 0,59/ 0,90m. Con 2 plataformas elevadas y 2 zonas de juego-reunión-escondite bajo las mismas. Dimensiones de área de juego 4,67 x 3,65 x 1,90m y 36,50m², incluidas las áreas de impacto. Incluye 14 elementos de juego tematizados:

- 2 toboganes de polietileno, de 0,9 y 0,6m de altura respectivamente.
- 4 monstruitos Spooky de gran formato, realizados en polietileno de alta densidad, bicolor, de 19mm de espesor.
- Panel interactivo "Spooky Quiz".
- Panel interactivo "Shop Abacus", para practicar matemáticas y psicomotricidad fina, con botones deslizantes de colores.
- Juego interactivo de psicomotricidad fina "Crazy Eyes" en monstruito del ábaco.
- Rampa-rocódromo antideslizante "Frankie".
- Rampa móvil colgante tematizado "Spooky Face", de polietileno engomado texturado y antideslizante.
- Gran Mirador-claraboya en plataforma superior, de policarbonato transparente.
- Mirador-claraboya mediana "Spooky Mask".
- Juego interactivo de psicomotricidad fina "Crazy Eye" en monstruito rampa "Frankie".

Materiales/

- Estructuras hexagonales en tubo de acero galvanizado y pintado con poliéster termoendurecido, de sección 50x50mm.
- Paneles de polietileno de alta densidad de 19mm, libre de mantenimiento y antigraffiti.
- Toboganes en polietileno de alta densidad.
- Plataformas y rampas en polietileno revestido de caucho antideslizante de 21mm de espesor.
- Claraboyas de policarbonato especial para la intemperie.
- Redes de poliamida de Ø16mm con 6 almas de acero.
- Tapones protectores de poliamida.
- Tornillería en acero inoxidable.
- Anclajes cincados / galvanizados.

Disponibilidad de repuestos durante 10 años.

Industrias Agapito se reserva el derecho a modificar sin previo aviso los elementos descritos en este documento.

**Description/**

Children Playset composed of a patented system of stackable hexagonal modules, forming a cellular “honeycomb” structure, under the “SPOOKY” theme and with three different levels for playing: 0 / 0.59 / 0.9m. It is composed of 2 elevated platforms and 2 playing- seek & hide – meeting zones underneath. Area dimensions 4.67 x 3.65 x 1.90m and playing area of 36.50 m² (impact areas included). It disposes of 14 elements of themed games:

- 2 HDPE slides of 0.90m and 0.60m high.
- 4 HDPE bicolor large format Spooky monsters, of 19mm thick.
- Interactive panel “Spooky Quiz”.
- Interactive panel “Shop abacus”, to work on mathematics skills and with colorfull sliding buttons to improve fine psichomotricity abilities.
- Fine psichomotricity interactive game “Crazy Eyes” within the abacus little monster.
- Non-slip ramp-climbing wall “Frankie”.
- Suspended moving ramp under the “Spooky Face” theme, made of non-slip, texturized, rubber coated polyethylene.
- Great transparent polycarbonate viewpoint-skylight on an upper platform.
- Middle size viewpoint-skylight “Spooky Mask”.
- Interactive fine psichomotricity game “Crazy Eye” within the little monster ramp “Frankie”.

Materials/

- Thermo-hardened polyester painted galvanized tubbed hexagonal structures of 50x50mm thick.
- HDPE panels of 19mm thick, maintenance-free and anti-graffiti.
- HDPE slides.
- Platforms and ramps made of 21mm thick non-slip rubber coated polyethylene.
- Polycarbonate skylights specially designed for outdoors.
- Polyamide ropes of Ø16mm reinforced with 6 steel cored strips.
- Polyamide protecting caps.
- Stainless steel screws and bolts.
- Fixations: zinc-coated / hot-dip galvanized steel.

Spare parts available for 10 years.

Industrias Agapito reserves the right to change the items described in this document without prior notice.

**Description/**

Structure multi-jeux pour enfants composé d'un système breveté de modules hexagonaux empilés, formant une structure cellulaire "en nid d'abeille", à thème effrayant "SPOOKY", avec différents niveaux de jeu: 0 / 0,59 / 0,9m. La structure comprend 2 plateformes surélevées et 2 zones de jeu pour jouer, se réunir ou se cacher. Dimensions de l'aire de jeux y compris les zones d'impact: 4,67 x 3,65 x 1,90m et 36,50m². Elle intègre 14 jeux, dont certains d'entre eux à thème interactif. Composée par:

- 2 toboggans en polyéthylène (hauteur de 0,6 et 0,9m).
- 4 monstres Spooky grand format, fabriqués en polyéthylène de haute densité, bicolore, de 19mm d'épaisseur.
- Panneau interactif " Spooky Quiz".
- Panneau interactif "Shop Abacus", pour la pratique des maths et de la motricité fine, avec des boutons coulissants de couleur.
- Jeu interactif de motricité fine "Crazy Eyes" dans le petit monstre du boulier.
- Rampe –mur d'escalade anti dérapant "Frankie".
- Rampe mobile suspendue à thème figure effrayante "Spooky Face", en polyéthylène caoutchouté, texturé et anti dérapant.
- Mirador - lucarne de grande taille dans la plateforme supérieure, en polycarbonate transparent.
- Lucarne de taille moyenne "Spooky Mask".
- Jeu interactif de motricité fine "Crazy Eye" dans le petit monstre avec rampe "Frankie".

Matériaux /

- Structures hexagonales en tube d'acier galvanisé avec peinture polyester thermodurcissable, section 50x50mm.
- Panneaux en polyéthylène de haute densité de 19mm d'épaisseur, anti graffiti et sans entretien.
- Toboggans en polyéthylène de haute densité.
- Plateformes et rampes en polyéthylène revêtu de caoutchouc anti dérapant de 21mm d'épaisseur.
- Lucarnes en polycarbonate résistant aux intempéries.
- Cordes en polyamide Ø 16 mm avec 6 âmes en acier.
- Bouchons de protection en polyamide.
- Visserie en acier inoxydable.
- Ancrages zingués / galvanisés.

Disponibilité de pièces de rechange pendant 10 ans.

Industrias Agapito se réserve le droit de modifier à tout moment et sans préavis les éléments décrits dans le présent document.