

ÁREA DE IMPACTO / ALTURA DE CAÍDA LIBRE
 IMPACT ZONE / FREE HEIGHT OF FALL
 ZONE D'IMPACT / HAUTEUR DE CHUTE LIBRE

A - 2,26 m² / 1,00 m
 B - 14,46 m² / 1,30 m
TOTAL = 16,72 m²

Superficie según EN 1176
 Surface according to EN 1176
 Revêtement conformément à la Norme EN 1176

R4823A

Suelo de hormigón
 Concrete ground
 Fixation sur béton

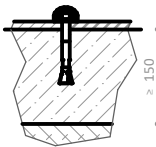

x10

R4823E

Otros suelos
 Other grounds
 Autres sols

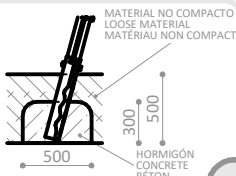

x2

PIEZA MÁS GRANDE
 BIGGEST PART
 LA PLUS GRANDE PIÈCE
2241 x 837 x 470 mm

PIEZA MÁS PESADA
 HEAVIEST PART
 LA PIÈCE LA PLUS LOURDE
55 Kg

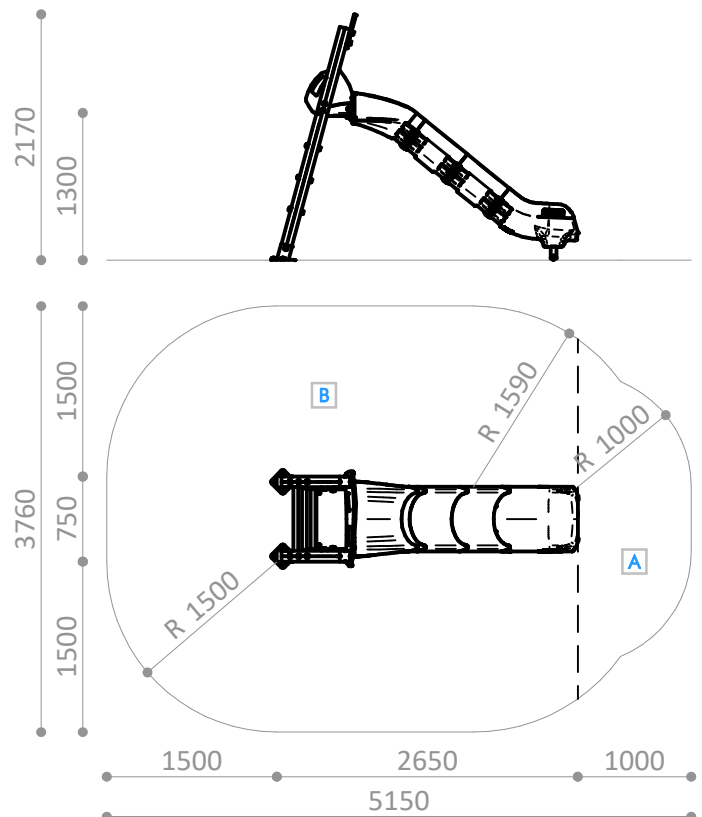



 **Descripción/** Tobogán de polietileno de alta densidad con estructura de madera tratada.

- Materiales/**
- Estructura de madera Pino Rojo del Norte, tratada en autoclave a nivel P4 y acabada con lásur, protector de la madera a poro abierto, hidrófugo, fungicida y con doble filtro anti U.V.
 - Tobogán de polietileno de alta densidad.

 **Description/** High density polyethylene slide with treated wood structure.

- Materials/**
- P4 Vacuum pressure treated Pine wood structure, with open pore, waterproof, fungicide and ultraviolet radiation protection.
 - Polyethylene slide.

 **Description/** Toboggan en polyéthylène, avec structure en bois traité.

- Matériaux/**
- Structure en Pin du Nord, traité en autoclave et finition lasurée, protecteur du bois à pores ouverts, hydrofuge, fungicide et avec double protection U.V
 - Toboggan en polyéthylène.

Disponibilidad de repuestos durante 10 años.
Spare parts available for 10 years.
Disponibilité de pièces de rechange pendant 10 ans.

Industrias Agapito se reserva el derecho a modificar sin previo aviso los elementos descritos en este documento.
Industrias Agapito reserves the right to change the items described in this document without prior notice.
Industrias Agapito se réserve le droit de modifier à tout moment et sans préavis les éléments décrits dans le présent document.

