

ÁREA DE IMPACTO / ALTURA DE CAÍDA LIBRE
IMPACT ZONE / FREE HEIGHT OF FALL
ZONE D'IMPACT / HAUTEUR DE CHUTE LIBRE

A - 18,00 m² / 0,22 m

Superficie según EN-1176-1
Surface according to EN-1176-1
Revêtement conformément à la Norme EN-1176-1

R5015A

Suelo de hormigón

Concrete ground

Fixation sur béton

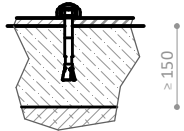

x4

R5015E

Otros suelos

Other grounds

Autres sols

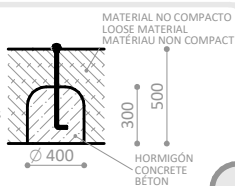

x4

PIEZA MÁS GRANDE
BIGGEST PART
LA PLUS GRANDE PIECE
1649 x 1412 x 19 mm

PIEZA MÁS PESADA
HEAVIEST PART
LA PIECE LA PLUS LOURDE
27,00 Kg

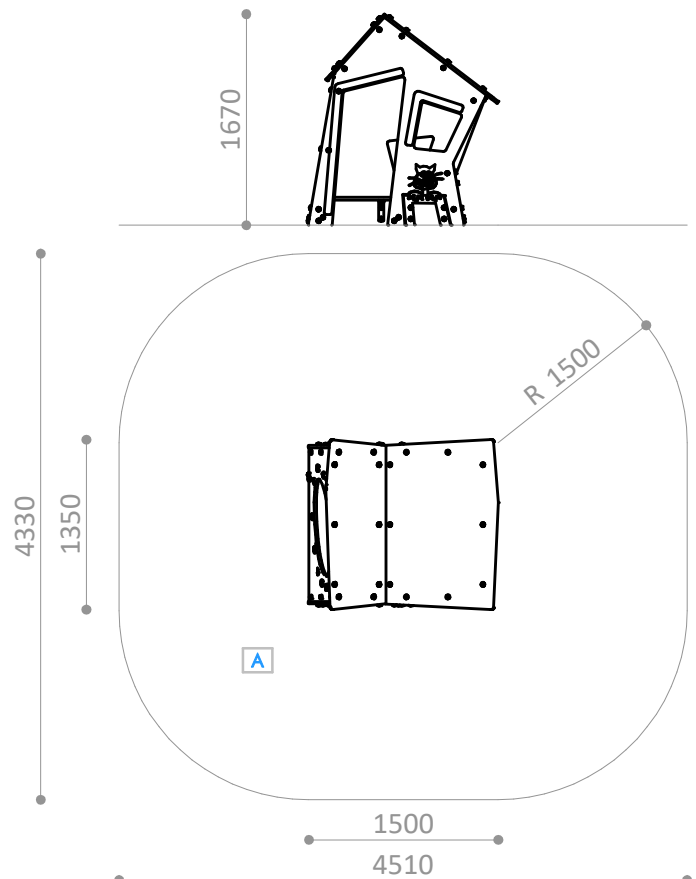



 **Descripción/** Casita tienda. Incluye ventanas, bancos y lateral con tienda. Decoraciones didácticas grabadas.

- Materiales/**
- Polietileno de alta densidad, libre de mantenimiento y antigraffiti.
 - Partes metálicas en acero galvanizado
 - Kit de fácil montaje.

 **Description/** With windows, benches and side wall with a Store. Includes educational panels.

- Materials/**
- Antigrffiti, maintenance-free HDPE.
 - Galvanized steel parts.
 - Easy assembly kit.

 **Description/** Petite maison avec boutique. Avec fenêtres, sièges et boutique dans un côté. Avec décoration éducative/didactique gravée.

- Matériaux/**
- Polyéthylène haute densité, sans entretien et antigraffiti.
 - Pièces métalliques en acier galvanisé.
 - Kit de montage simple.

Disponibilidad de repuestos durante 10 años.

Spare parts available for 10 years.

Disponibilité de pièces de rechange pendant 10 ans.

Industrias Agapito se reserva el derecho a modificar sin previo aviso los elementos descritos en este documento.

Industrias Agapito reserves the right to change the items described in this document without prior notice.

Industrias Agapito se réserve le droit de modifier à tout moment et sans préavis les éléments décrits dans le présent document.

