



### Descripción/

Mejora el equilibrio y la motricidad del tren inferior. Aumenta la coordinación óculo-pédica.

**Juegos:** Ponerse de pie con manos, caminar en equilibrio y sentarse y ponerse de pie sin manos.

### Materiales/

- Polietileno de alta densidad, libre de mantenimiento y antigraffiti.
- Pieza superior revestida de caucho antideslizante.
- Partes metálicas en acero galvanizado.
- Tornillería de acero inoxidable.



### Description/

Improves balance and lower-body motor skills. Increases foot-eye coordination

**Games:** Stand-up using hands, balance walking and sit and stand-up without hands.

### Materials/

- Antigraffiti, maintenance-free HDPE.
- Antislippery rubber covered HDPE top panel.
- Galvanized steel metal parts.
- Stainless steel screws.



### Description/

Améliore l'équilibre et la motricité de la partie inférieure. Augmente la coordination œil-pieds.

**Jeux:** Se lever avec les mains, marcher en équilibre et s'asseoir et se lever sans les mains.

### Matériaux/

- Polyéthylène haute densité, sans entretien et antigraffiti.
- Pièce supérieure revêtue en caoutchouc antidérapant.
- Pièces métalliques en acier galvanisé.
- Visserie en acier inoxydable.

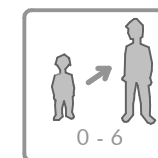
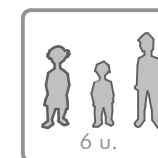
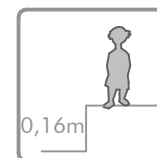
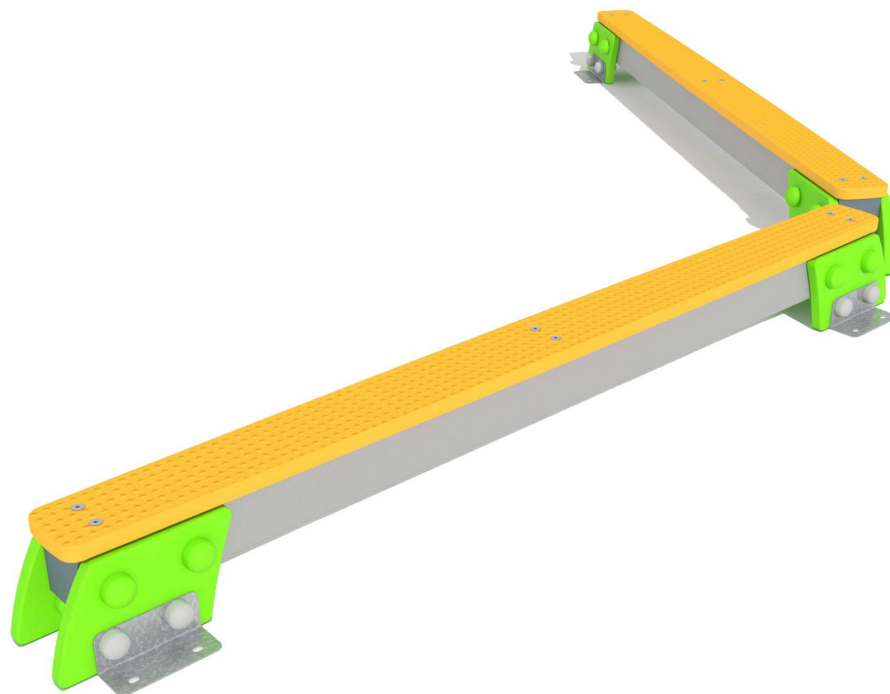

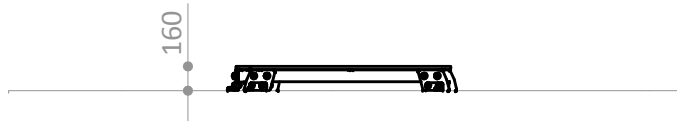

ESPACIO DE SEGURIDAD / ALTURA DE CAIDA LIBRE  
 SAFETY AREA / FREE HEIGHT OF FALL  
 ZONE DE SECURITÉ / HAUTEUR DE CHUTE LIBRE

A - 17,1 m<sup>2</sup> / 0,16 m

Superficie según EN-1176-1  
 Surface according to EN-1176-1  
 Revêtement conformément à la Norme EN-1176-1

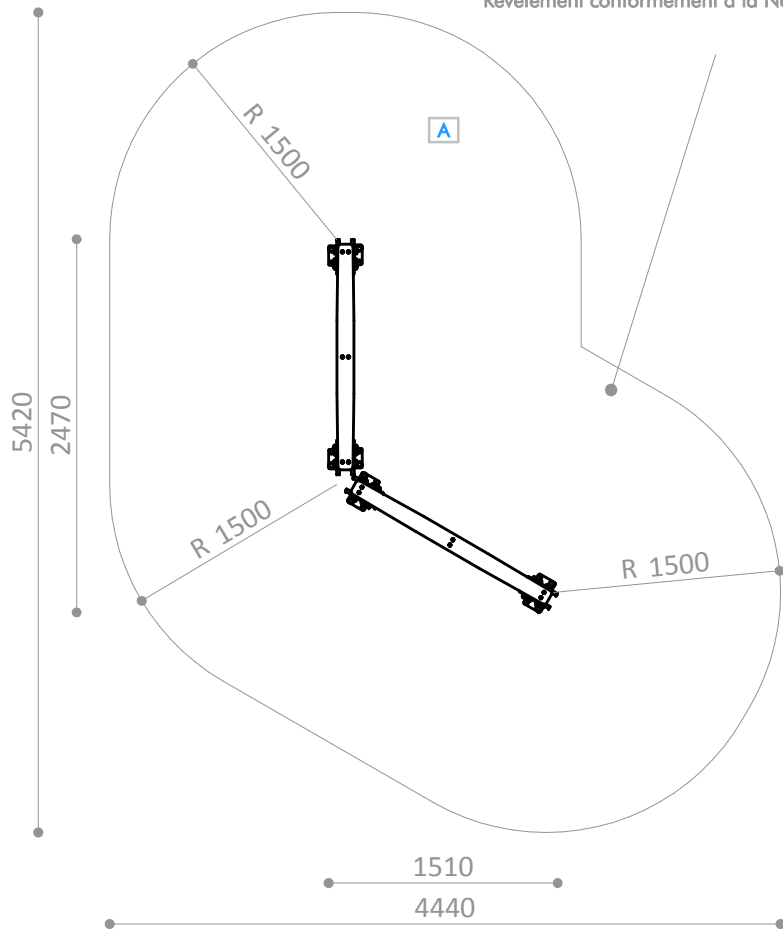

### R5202

Pieza más grande

Biggest part

La plus grande pièce

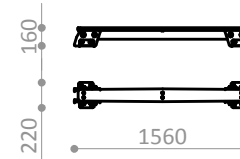

### R5202

Pieza más pesada

Heaviest part

La pièce la plus lourde

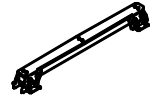

15 Kg.

### R5205A

Suelo de hormigón

Concrete ground

Fixation sur béton

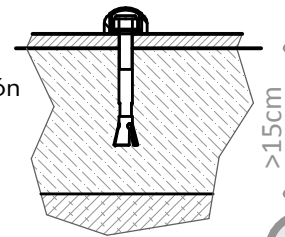

x8

### R5205E

Otros suelos

Other grounds

Autres sols

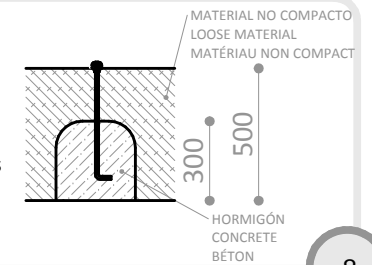

x8

Disponibilidad de repuestos durante 10 años.  
 Spare parts available for 10 years.  
 Disponibilité de pièces de rechange pendant 10 ans.

Industrias Agapito se reserva el derecho a modificar sin previo aviso los elementos descritos en este documento.  
 Industrias Agapito reserves the right to change the items described in this document without prior notice.  
 Industrias Agapito se réserve le droit de modifier à tout moment et sans préavis les éléments décrits dans le présent document.

