



GRIDCON® ACF

ACTIVE FILTERS
FOR CLEAN GRIDS.
FOR ANY ENVIRONMENT.

WWW.REINHAUSEN.COM



GRIDCON® ACF INDUSTRIAL VERSION FOR ROUGH AMBIENT CONDITIONS AND CHALLENGING TASKS UP TO 690 V.

Page 4 onwards



GRIDCON® ACF BUILDING VERSION FOR NEUTRAL CONDUCTOR COMPENSATION AND STRINGENT EMC REQUIREMENTS.

Page 6 onwards



KEEPING GRIDS CLEAN: ACTIVE FILTERS.

Negative impacts on power quality, caused by frequency-controlled drives, welding lines or computers' power supply units for example, can have serious consequences: if a sensitive device, such as an electronic control unit, is damaged by harmonics, total production failure may result. Even the supply grid itself can experience impermissible interference or dangerous overloading due to reactive power, load imbalance, fluctuation in voltage (flicker), and high harmonic currents.

Active filters reliably and accurately compensate for this interference. They measure current and voltage of a grid section and supply precisely the amount of current required for the desired effect. When harmonics arise, currents are actively generated, opposing the interference in the grid, so that the harmonics are wiped out. To reduce voltage fluctuations (flicker), active filters make use of the fact that inductive reactive power reduces the line voltage and capacitive reactive power increases it. Active filters therefore reliably take the strain off grids, extend the service life of devices and increase the safety of industrial systems.

Compared with conventional, passive filters, active filters can be set very accurately to the prevailing requirements at any time – without the risk of overload. Because the systems can be smaller in size and dynamically regulate their filter flow, they result in fewer losses. Active filters are a future-proofed investment for both industrial networks and buildings.

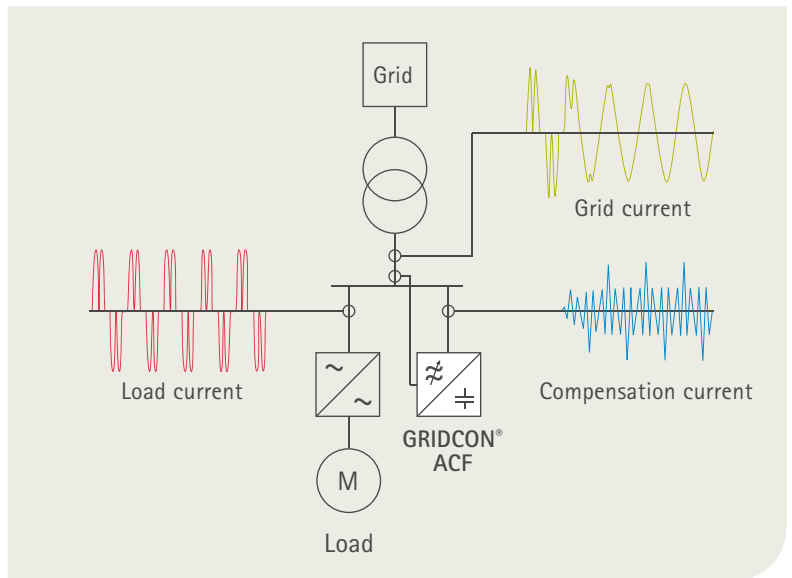

GRIDCON® ACF COMPACT FOR SMALLER RATINGS IN 3- OR 4-WIRE OPERATION
Page 8 onwards



GRIDCON® ACF INDUSTRIAL VERSION.

Handling challenging tasks up to 690 V under rough ambient conditions.

Touch panel with uniform GRIDCON® ACF operating software

CCU (Control Computer Unit) for up to six power modules (IPU)

Modular concept: up to four independent power modules (IPUs) per cabinet

Slot for Anybus communication modules

Adjustable control transformer combined with a wide range DC supply allows for use in low-voltage grids worldwide

Mobile measuring unit (MIO) – central current and voltage measurement, digital inputs and outputs

Separate fan for cooling the peripheral components, degree of protection up to IP 54 possible

IPU IGBT power unit with autonomous control and self-monitoring

Extension option for additional 125 A power unit (IPU)

Fan drawer for simple replacement of the main fans

Behind the terminal compartment: isolated ventilation duct without live parts for the IGBT's main cooling – air is supplied through the floor / base



GRIDCON® ACF Industrial version, 375 A, special color

GRIDCON® ACF Industrial version is the number one choice for challenging compensation tasks where reliability and safety are needed, for example, even beyond normal operating voltages and under challenging ambient conditions:

- Operation up to 690 V and higher at full power without derating
- Rated current can be extended in a modular manner from 125 A to 3,000 A, e.g. for STATCOM systems
- High power density and compact design
- Low losses
- Very durable film capacitors
- Overvoltage category III up to 1000 V – even in grids with isolated neutral point (IT network configuration)
- Degree of protection up to IP 54 possible, optional external water cooling for complete encapsulation
- Dynamic compensation of reactive power, harmonics, and flicker, as well as load balancing in one unit

Its very special plus points make GRIDCON® ACF Industrial version the number one choice in many areas:

- Production lines, e.g. automotive
- Mining
- Chemical industry
- Larger printing plants
- Cranes and transport systems
- Offshore platforms and ships
- Oil and gas
- Paper industry
- Steel processing
- Water treatment and pump stations

Intuitive operation by means of touch panel or PC

The central operating and display element of GRIDCON® ACF is a touch panel. It has a clear menu structure and can display data in both tables and diagrams. The benefits of the touch panel include:

- Simple parameterization of the filter function without additional measuring devices
- Explanations and status messages in plain text
- Intuitive operation and password protection

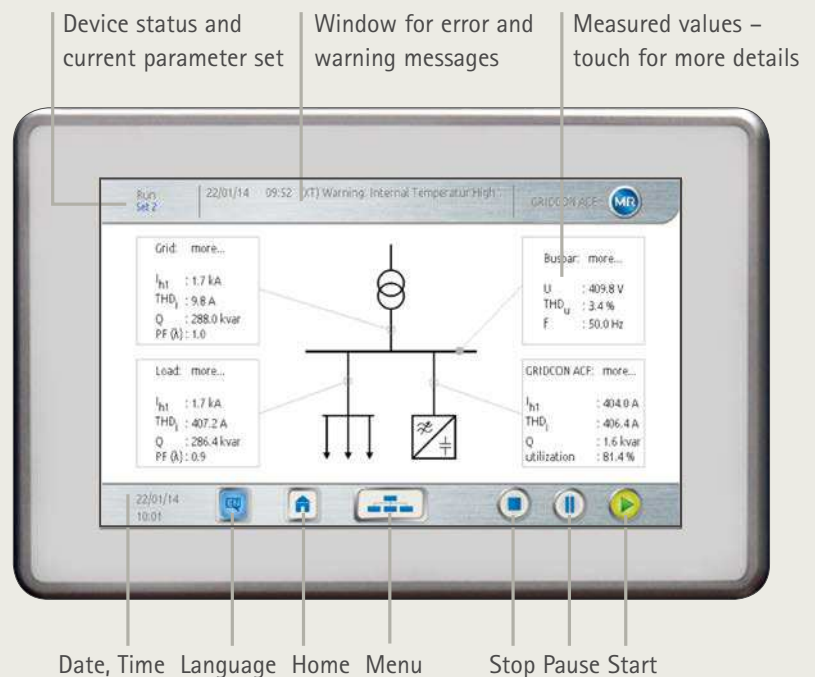

GRIDCON® ACF can also be operated via the web. Once incorporated into a company network or connected via a mobile phone network, it can be monitored or parameterized remotely using a browser.

GRIDCON® ACF BUILDING VERSION.

The decentralized way to unload the neutral conductor while meeting stringent EMC requirements.

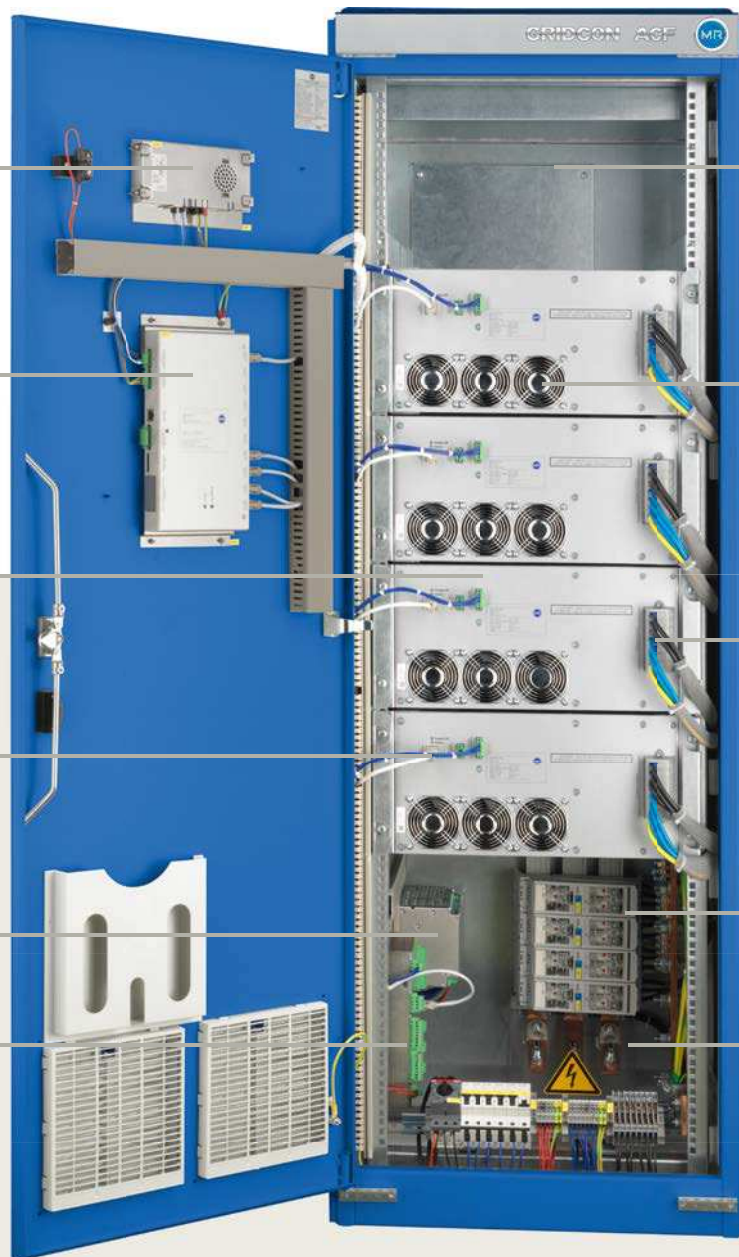

Touch panel with uniform GRIDCON® ACF operating software

CCU (Control Computer Unit) for up to five power modules (IPU)

Up to five IPUs (IGBT Power Units) with autonomous control and self-monitoring

Power modules controlled by DSC-Distributed Synchronous Control®

Wide range DC supply

Mobile measuring unit (MIO) – central current and voltage measurement, digital inputs and outputs

Extension option for additional 60 A power unit (IPU)

Speed-controlled fan for cooling the power modules and cabinet, degree of protection up to IP 21 possible

Special version available for stringent EMC requirements (emission class B in accordance with EN55011)

Separate fuses for each power module

Phase conductor and neutral conductor connection which can be compensated with up to three times the phase conductor current

GRIDCON® ACF Building version, 240 A, special color

GRIDCON® ACF Building version is a 4-wire device. If necessary, currents in the neutral conductor can be filtered at up to three times the rated current. Moreover, the device is very compact. If requested by the customer, it can also meet very stringent EMC standards for use in residential environments. Outside industrial environments, power quality is often specifically improved in a decentralized manner in the sub-distributions:

- 4-wire device with up to three times the neutral conductor current
- Operation up to 415 V +10% at full power without derating
- Rated current can be extended in a modular manner in small units from 60 A to 300 A

- High power density and extremely compact design
- Low losses
- Degree of protection up to IP 21 possible
- Dynamic compensation of reactive power, harmonics, and flicker, as well as load balancing and neutral conductor relief in one unit

GRIDCON® ACF Building version is particularly at home in these areas:

- Offices and commercial buildings
- Renewable energy
- Data centers
- Hospitals

MIO mobile measurement unit

Can be used in decentralized manner: The MIO can be positioned near current transformers if necessary. A standard network cable connects to the control computer.

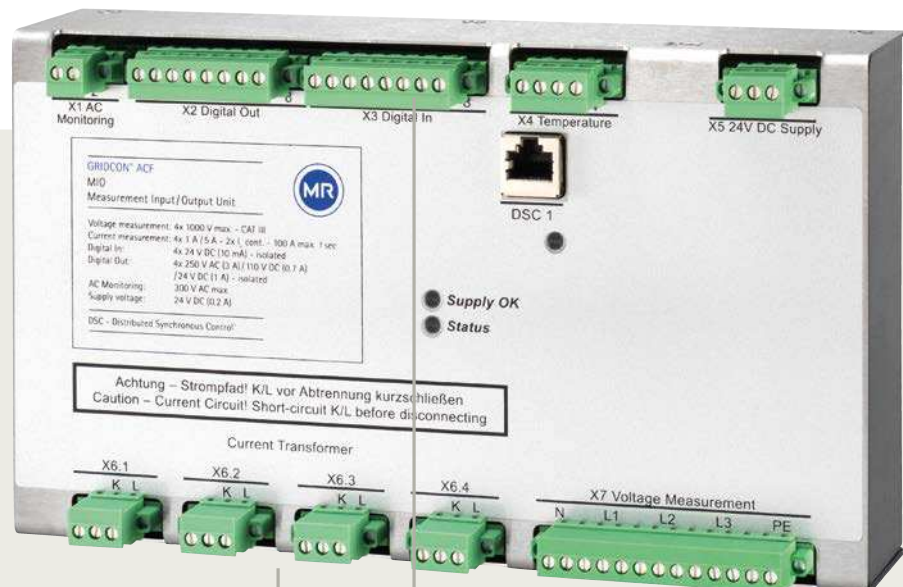

- Four current inputs can be used separately
- Measurement with high-precision A/D converters
 - Can be switched over: 1A / 5A
 - Can be overloaded: up to 100 A for 1 second

Isolated digital inputs and outputs

Measurement voltage up to 1000 V and high overvoltage resistance (CAT III)

GRIDCON® ACF COMPACT.

A big hit for smaller ratings and tight spaces in 3- or 4-wire environments.

GRIDCON® ACF compact is always used when only smaller ratings are needed and space is tight. The device offers the same features as GRIDCON® ACF Building version, but in a very compact form:

- 4-wire device with up to three times the neutral conductor current
- Operation up to 415 V +10% at full power without derating
- Rated current of 60 A, can be extended in a modular manner
- The most compact design of all GRIDCON® ACF versions
- Low losses
- Dynamic compensation of reactive power, harmonics, and flicker, as well as load balancing and neutral conductor relief in one unit

Its special characteristics make GRIDCON® ACF compact ideal for decentralized use and suitable for:

- Offices and commercial buildings
- Additions to rectifiers
- Hospitals
- Industrial plants with small connection ratings

Wall mounting allows for space-saving installation and decentralized use

Touch panel with uniform GRIDCON® ACF operating software

Proven MR technology on the inside: Contains an IGBT Power Unit with autonomous control and self-monitoring along with a CCU (Control Computer Unit)

Phase conductor and neutral conductor connection which can be compensated with up to three times the phase conductor current

Connection of the externally fitted mobile measuring unit (MIO) – central current and voltage measurement along with digital inputs and outputs, which is normally installed directly in the distribution

Speed-controlled fans

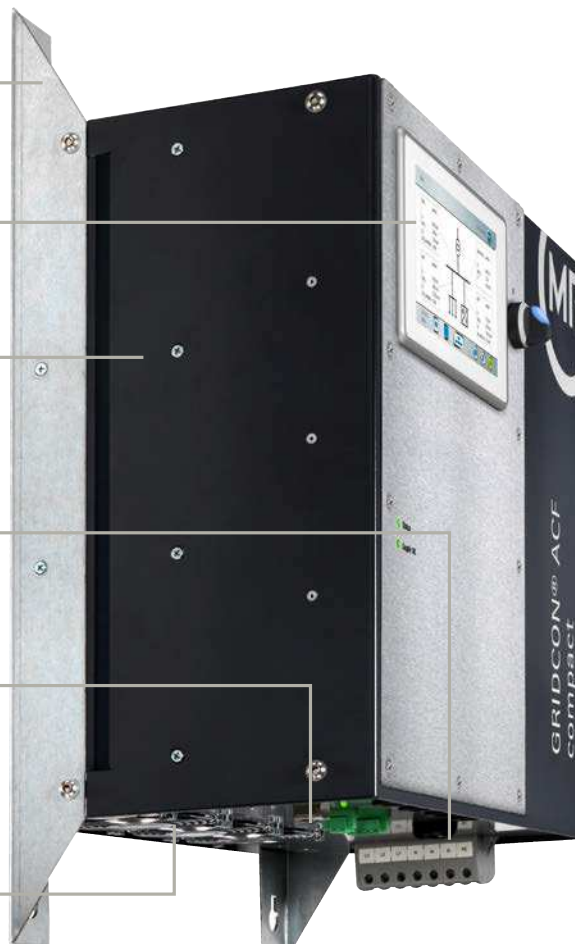

ARCHITECTURE: NETWORKED. INSTALLATION: FLEXIBLE. HANDLING: SIMPLE.

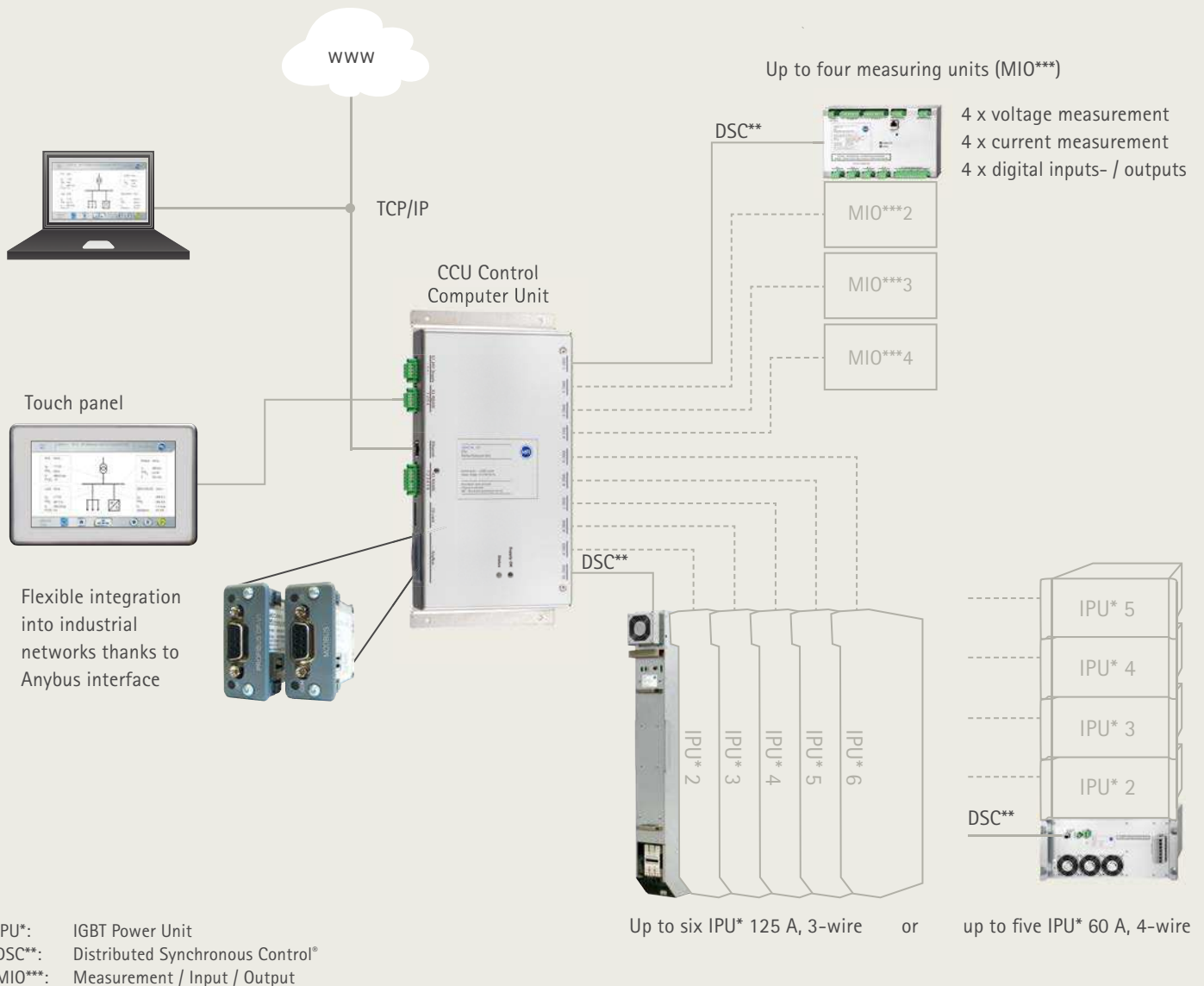

The networked architecture of GRIDCON® ACF provides great flexibility: An Anybus interface on the controller facilitates easy integration into industrial networks. Furthermore, all internal connections offer simple, error-free assembly and particularly reliable communication – even under the influence of electromagnetic disturbance. The internal bus architecture allows for good spatial flexibility. For example, GRIDCON® ACF and MIO can be installed in different rooms. The current can

also be measured at different points with one or more MIOs. This is important for supply networks, for example, which have several feeders or an emergency power supply. The „DSC-Distributed Synchronous Control®“ technology takes care of synchronized communication between all components – ensuring that the spatially distributed measurement and control system of GRIDCON® ACF performs well at all times.

GRIDCON® ACF.

Building on experience.

Development of the GRIDCON® ACF product range integrated years of MR's experience in designing and operating passive and active filters. The result is a product range with the right filter for any application. Despite all the differences, the individual GRIDCON® ACF variants have a lot in common: They have a modular structure, low losses, and are synonymous with extreme reliability.

Modularity principle: Maximum scope for extensions

All filters in the GRIDCON® ACF range have a modular structure and can be accurately sized and extended at any point. The difference is in the detail: Each module of GRIDCON® ACF Industrial version delivers an effective current of 125 A. In the standard variant, up to six modules can be combined, producing a total current of 750 A. By adding more controllers, systems with up to 3,000 A are possible. Such current levels are rare in building technology. The effective current in GRIDCON® ACF Building version is therefore 60 A per module to make the right size possible. Extension units can even be added to GRIDCON® ACF compact.

High stability, short service times

Its modular structure makes the GRIDCON® ACF product range particularly resilient to faults. Should one module fail, the other units take over until the error is rectified. Diagnosis of disturbances is also well thought-out. An SD memory card in the controller records the system's operating statuses. The data can therefore be quickly read out and sent to MR's Power Quality team for evaluation. Practical service approach: The system is designed such that individual components can be quickly and easily replaced by the operator himself.

GRIDCON® ACF Industrial version with 125 A extension module



GRIDCON® ACF Building version with 60 A extension module



GRIDCON® ACF compact with 60 A extension module

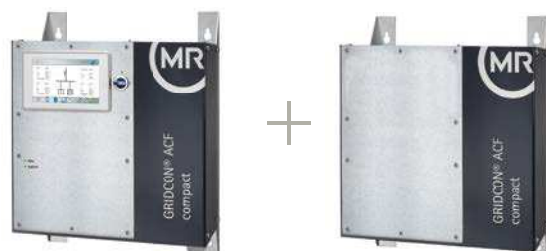

THE 3-LEVEL TECHNOLOGY.

Low losses and high dielectric strength.

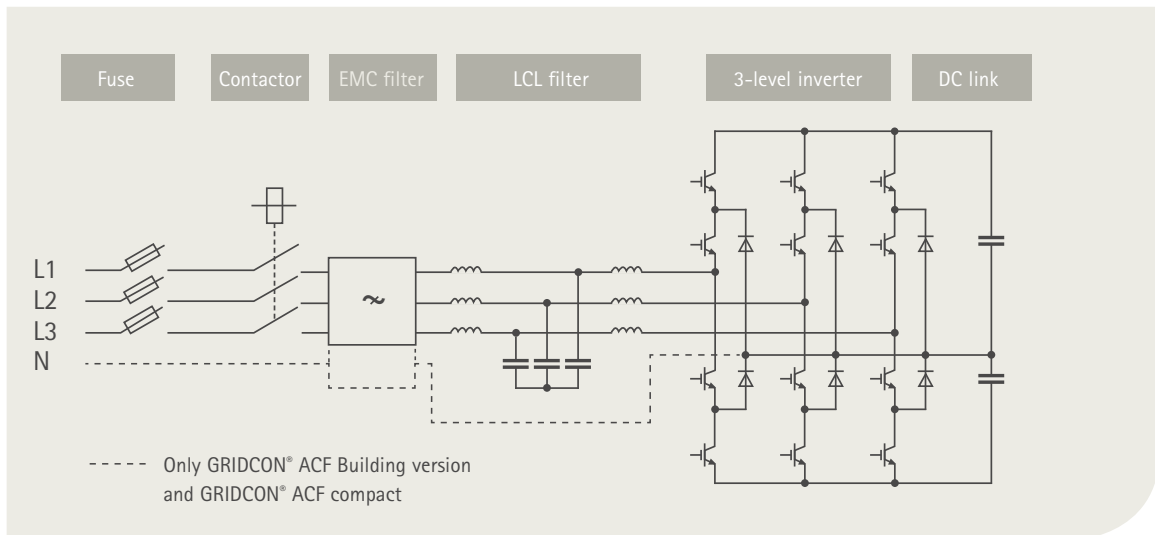

The 3-level circuit of GRIDCON® ACF is based on twelve IGBTs, whereas conventional 2-level active filters only comprise of six. The special circuitry halves the voltage load of the power semiconductors. On the one hand this results in lower losses and on the other hand enables use in grids with a higher rated voltage. The DC link voltage is also higher which allows higher peak currents to be generated, which

is essential for filtering harmonics with a high bandwidth. Another benefit of the 3-level technology is the lower ripple of the output current compared with the 2-level architecture. The split DC link and the larger number of IGBTs result in an additional third inverter state at the output. This can be used to make the line filter and EMC filter more compact with the same switching frequency and thereby reduce losses.

Switching status and resulting current ripple – 2-level architecture

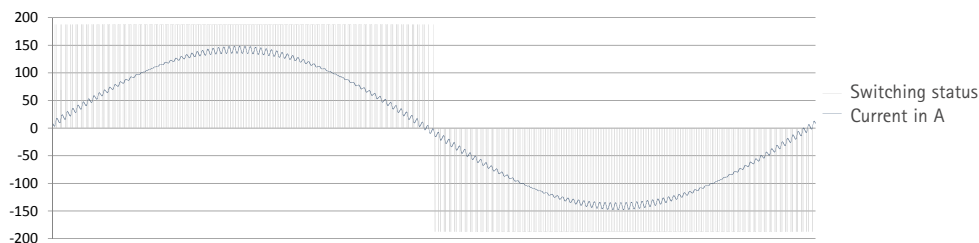

Switching status and resulting current ripple – 3-level architecture

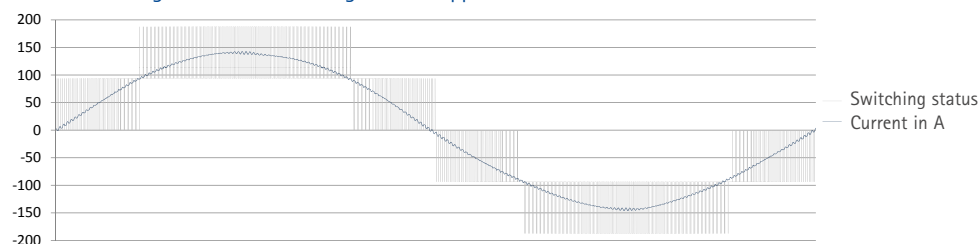

USE IN AN INDUSTRIAL ENVIRONMENT.

GRIDCON® ACF in the automotive industry.

In the automotive industry in particular, today most of the loads are electronic power consumers. Here production lines are often operated by robots whose inverter drives feed harmonics of different frequencies into the electrical distributions. These harmonics cause warming and therefore premature aging of electrical equipment, potentially leading to the failure of electronic controllers and result in the overloading of transformers and cables. What's more, harmonics increase energy consumption.

The specific use of active filters can reduce voltage distortion over a wide frequency range. This enables the compliance to stipulated limits in standards and relieves the strain on equipment.

Limit value infringements due to harmonics of the order of 5, 43, and 49 can be seen in the example

shown below. Using an active filter not only enables compliance with all voltage limit values, but also reduces the current load on the transformer by nearly 500 A.

Flexible use and scope for extending equipment is also very important in industrial settings. A larger production line also requires the compensation capacity to be increased. GRIDCON® ACF can „grow“ with production facilities as it allows additional modules to be installed in the existing cabinet.

Despite very different load characteristics, such as those encountered in the body shop and paintshop parts of production, identical versions of GRIDCON® ACF can be used, ensuring low complexity in operation, service, and procurement.

Voltage in % of rated voltage

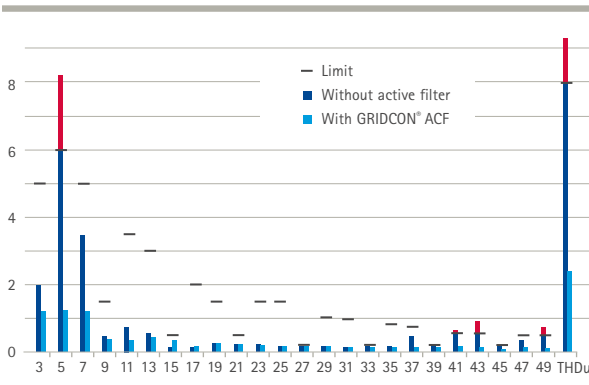

Current in A

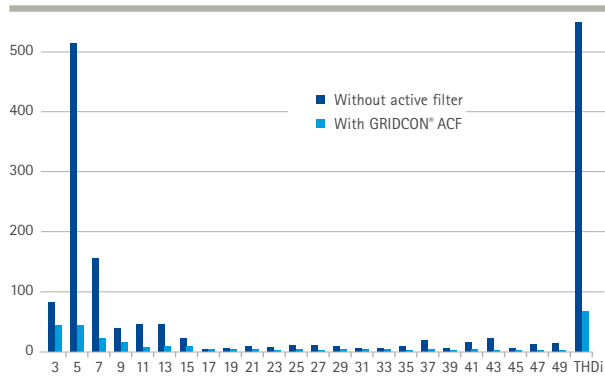

Current and voltage curves

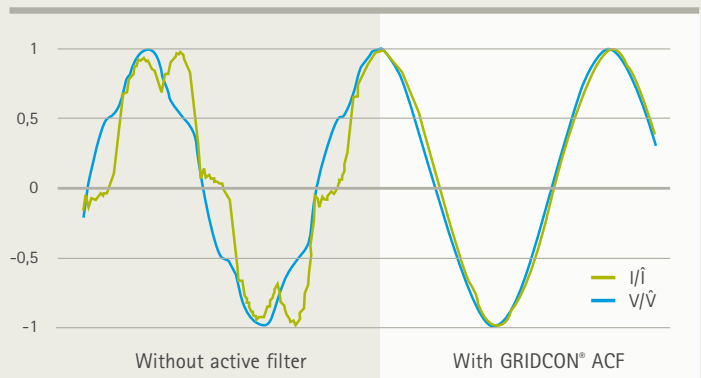

SUCCESSFUL UNDER EXTREME CONDITIONS.



STATCOM systems based on GRIDCON® ACF for offshore applications.

Offshore usage requires tried and tested technologies, that also have to work perfectly under the toughest conditions. And that is precisely what is expected of efficient energy distribution systems which are operated under the most stringent requirements in terms of availability of feed-in power, stability of the voltage supply, and power quality. Offshore platforms, for example used in wind farms or in the oil and gas industry, typically have a submarine cable connection and a parallel self-supply to ensure production should the land-based connection fail. It is here, where STATCOM systems, based on GRIDCON® ACF, ensure dynamic stabilization of the line voltage and regulation of the flow of reactive power, even under the conditions of limited supply.

Based on a combination of GRIDCON® ACF technology, a 3-winding coupling transformer, and adapted regulation, STATCOM systems can be derived which

provide up to 7.2 Mvar of dynamic compensation power. Typical control modes include voltage regulation and reactive power regulation. Depending on the application, the rise time is between 10 and 40 ms.

In offshore applications system responses to transient error scenarios are critical. Here STATCOM systems based on GRIDCON® ACF are able to use special Low-Voltage-Ride-Through (LVRT) and Fault-Ride-Through (FRT) strategies to stabilize the corresponding grids.

Dynamic reactive power step response

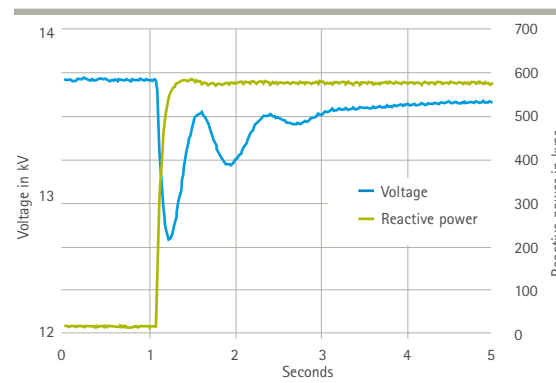

GRIDCON® STATCOM in fully air-conditioned offshore-container



MORE POWER, MORE VALUE.

GRIDCON® ACF – clean grids for any environment.



The right solution for every application

- One product range for various requirements: From the compact wall-mounted device to a combination of several cabinets with 3 Mvar
- The optimized power electronics enable use in a wide voltage range of less than 380 V to more than 690 V
- Given the isolated main cooling duct and low losses, reliable operation is possible under demanding environmental conditions



Fit for the future

- The modular concept simplifies subsequent expansion or modification, allowing the filters to grow with their tasks
- The operator can perform parameterization for new or changed tasks himself, ensuring long-term flexibility
- GRIDCON® ACF is already prepared for future functionality to compensate harmonics even beyond the 51st



Maximum operational reliability in all circumstances

- Overvoltage category III at rated voltages of up to 690 V enables safe operation – even in grids with isolated star point
- All devices comply at least with the EMC requirements of an industrial environment. As an option, the four-wire devices even satisfy the more stringent EMC class B for residential environments (EN55011)
- Comprehensive mechanical and electrical tests, going far beyond the requirements of type testing, demonstrate the highly robust construction



Low life-cycle costs

- The modular concept and networked architecture make demand-driven investments possible and reduce installation and service costs
- The guaranteed availability of spare parts and extension modules ensures a safe investment and long service life
- Extraordinarily low losses keep power consumption down and also reduce the cost of air conditioning



Ease of service and operation

- Intuitive, safe touch panel-based operation and monitoring using Ethernet or any other network thanks to optional Anybus communication modules
- A trained operator can easily check the system, change the fans or replace entire power modules himself
- Rapid and low-cost commissioning, troubleshooting, and product updates by means of SD memory card and system messages in plain text

TECHNICAL DATA.

Technical data	GRIDCON® ACF Industrial version							
Nominal voltage	400 V (maximum 480 V) +10%				690 V (maximum 800 V on request) +10%			
Nominal frequency	50 Hz / 60 Hz							
Peak current	2 x rated current							
Connection	3-phase + PE, neutral conductor connection not required (network topology: TN, TT, IT)							
Compensation	3-wire operation: Outer conductors balanced and unbalanced (positive and negative sequence)							
Filter function harmonics	1 st .. 51 st harmonic (50 Hz) // 1 st .. 41 st harmonic (60 Hz) All harmonics can be filtered simultaneously							
Additional functions	Dynamic reactive power compensation Active and reactive power balancing (up to 100% of rated current) Voltage stabilization via Q(U)-control Flicker compensation							
Power losses	< 2,5% of compensation power maximum, < 2,2% in typical operation, < 0,4% when idle, < 100 W in standby				< 2,1% of compensation power maximum, < 1,8% in typical operation < 0,4% when idle, < 100 W in standby			
Switching frequency	10 kHz (low-loss version)							
Control	Internal control computer with two digital signal processors							
Device setup and display	Via touch panel with graphic display or internal web server (TCP/IP) and PC – No additional software required							
Response time	<< 1 ms							
Interfaces	Ethernet (TCP/IP) Various field buses via optional Anybus modules (e.g. Profibus, Modbus) 4 x digital output (isolated, parameterized) for status messages 4 x digital input (24 VDC, parameterized) for external control and parameter set selection							
Current transformer	Either 2-phase or 3-phase current measurement, xx/5 A or xx/1 A (parameterized) Current transformers are not included, 15 VA, class 1 or better recommended							
Inverter	3-Level IGBT with voltage link (DC film capacitors)							
Coloring	Standard: RAL 7035 light grey (other colors and designs on request)							
Dimensions (approx. W x D x H)	800 x 600 x 2000 mm 800 x 600 x 2200 mm with optional base (needed for main air supply from front or back)							
Cooling	Standard: Air cooling with speed-controlled fans Optional: Liquid cooling with connection to external cooling system via heat exchanger unit							
IP protection degree	Standard: IP20, optional: IP21 .. IP54							
Ambient conditions	Maximum ambient temperature without derating: 40° C Recommended ambient temperature for continuous operation: < 25° C Minimum operating temperature: 0° C, relative humidity: maximum 95% Transport / storage: -20° C .. 70° C							
Number of modules	1	2	3	4	1	2	3	4
Compensation power	87 kvar	174 kvar	261 kvar	348 kvar	150 kvar	300 kvar	450 kvar	600 kvar
Rated current	125 A	250 A	375 A	500 A	125 A	250 A	375 A	500 A
Neutral current	–	–	–	–	–	–	–	–
Weight	About 340 kg	About 460 kg	About 580 kg	About 700 kg	About 340 kg	About 460 kg	About 580 kg	About 700 kg
Extendability	Up to a maximum of 5 cabinets (1,7 Mvar, 2,5 kA)				Up to a maximum of 5 cabinets (3 Mvar, 2,5 kA)			
EMC class	EN 55011, class A1 (industrial environment)							
Standards	EN 50178, EN 61439-1, EN 61439-2, EN 61000-6-2, EN 61000-6-4, EN 55011							

Technical data	GRIDCON® ACF Building version					GRIDCON® ACF compact
Nominal voltage	400 V (maximum 415 V) +10%					
Nominal frequency	50 Hz / 60 Hz					
Peak current	2 x rated current					
Connection	3-phase + PE + N / PEN, neutral conductor connection mandatory (network topology: TN)					
Compensation	3-wire operation: Outer conductors balanced and unbalanced (positive and negative sequence) 4-wire operation: Additionally neutral conductor (positive, negative and zero sequence)					
Filter function harmonics	1 st .. 51 st harmonic (50 Hz) // 1 st .. 41 st harmonic (60 Hz) All harmonics can be filtered simultaneously					
Additional functions	Dynamic reactive power compensation Active and reactive power balancing (up to 100% of rated current) Voltage stabilization via Q(U)-control Flicker compensation Neutral conductor relief					
Power losses	< 2,6% of compensation power maximum, < 2,3% in typical operation, < 0,7% when idle, < 100 W in standby					
Switching frequency	20 kHz (low-loss version)					
Control	Internal control computer with two digital signal processors					
Device setup and display	Via touch panel with graphic display or internal web server (TCP/IP) and PC – No additional software required					
Response time	<< 1 ms					
Interfaces	Ethernet (TCP/IP) Various field buses via optional Anybus modules (e.g. Profibus, Modbus) 4 x digital output (isolated, parameterized) for status messages 4 x digital input (24 VDC, parameterized) for external control and parameter set selection					
Current transformer	3-phase current measurement, xx/5 A or xx/1 A (parameterized) Current transformers are not included, 15 VA, class 1 or better recommended					
Inverter	3-Level IGBT with voltage link (DC electrolytic capacitors)					
Coloring	Standard: RAL 7035 light grey (other colors and designs on request)					Dark grey
Dimensions (approx. W x D x H)	Standard: 600 x 600 x 1800 mm Optional: Other form factors and dimensions on request					Device: 441 x 252 x 554 mm MIO: 243 x 77 x 143 mm
Cooling	Air cooling with speed-controlled fans					
IP protection degree	Standard: IP20, optional: IP21					
Ambient conditions	Maximum ambient temperature without derating: 40° C Recommended ambient temperature for continuous operation: < 25° C Minimum operating temperature: 0° C, relative humidity: maximum 95% Transport / storage: -20° C .. 70° C					
Number of modules	1	2	3	4	5	1
Compensation power	42 kvar	83 kvar	125 kvar	166 kvar	208 kvar	42 kvar
Rated current	60 A	120 A	180 A	240 A	300 A	60 A
Neutral current	180 A	360 A	540 A	720 A	900 A	180 A
Weight	About 225 kg	About 285 kg	About 345 kg	About 405 kg	About 465 kg	About 58 kg
Extendability	Up to a maximum of 5 modules (208 kvar, 300 A)					Up to 4 extension modules
EMC class	Standard: EN 55011, class A1 (industrial environment), optional: class B (residential environment)					
Standards	EN 50178, EN 61439-1, EN 61439-2, EN 61000-6-2, EN 61000-6-4, EN 55011					

DIMENSIONS.

GRIDCON® ACF Industrial version

Standard version with main air supply through the floor

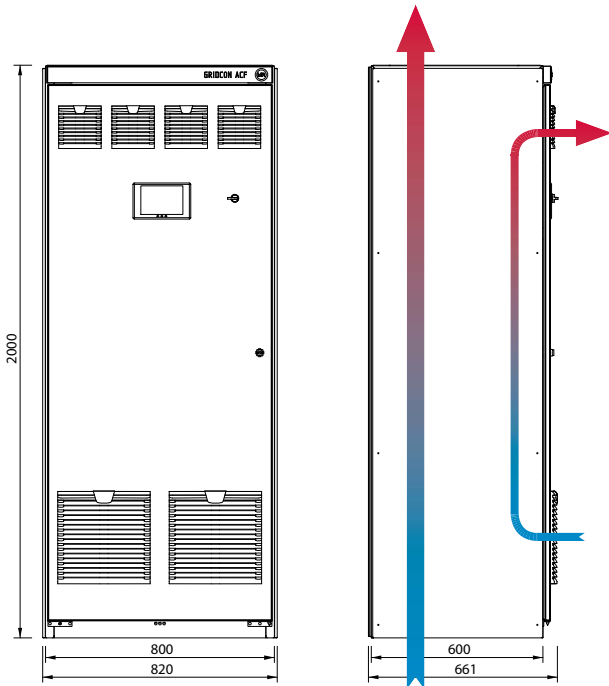

GRIDCON® ACF Industrial version

Version with optional base for main air supply from front or back

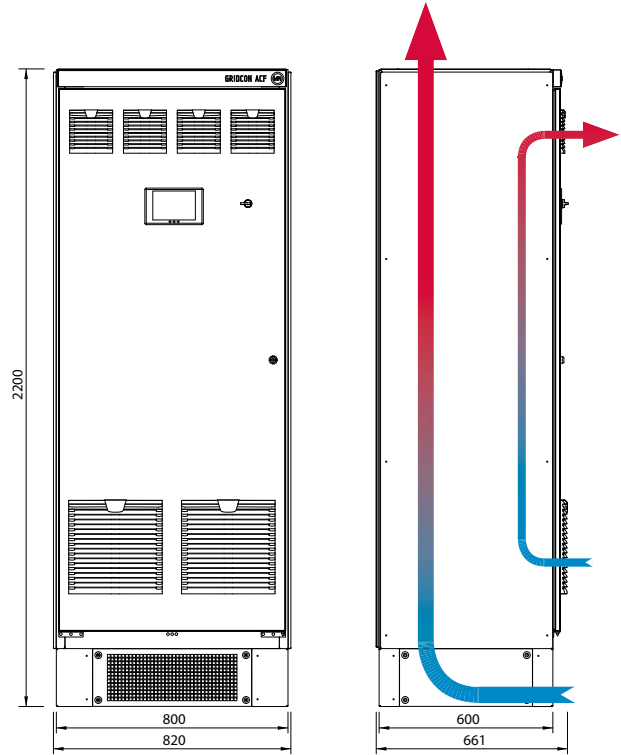

GRIDCON® ACF Industrial version with liquid cooling

Version with heat exchanger unit on top

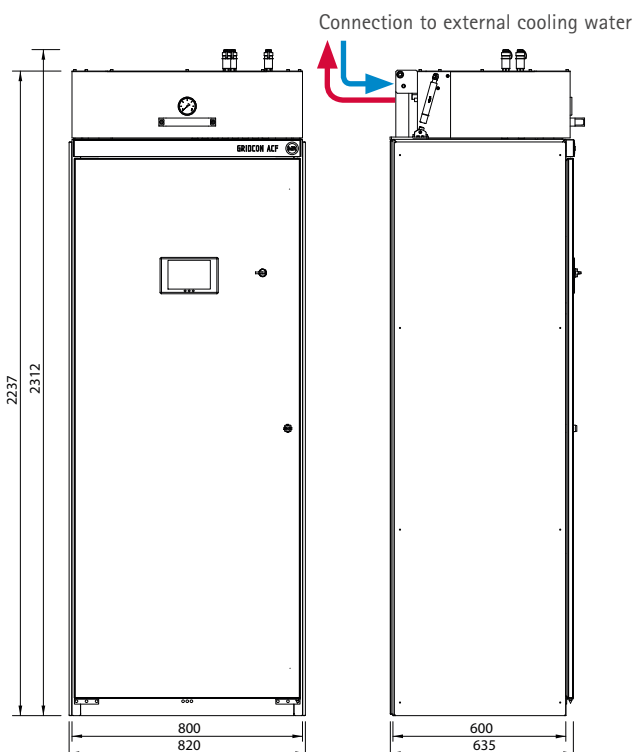

GRIDCON® ACF Building version

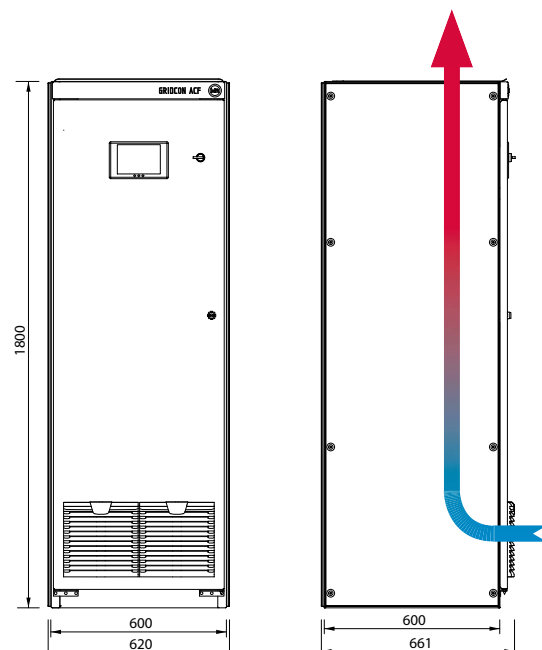

GRIDCON® ACF compact + MIO

Main device with integrated control computer, touch panel, main switch and MIO

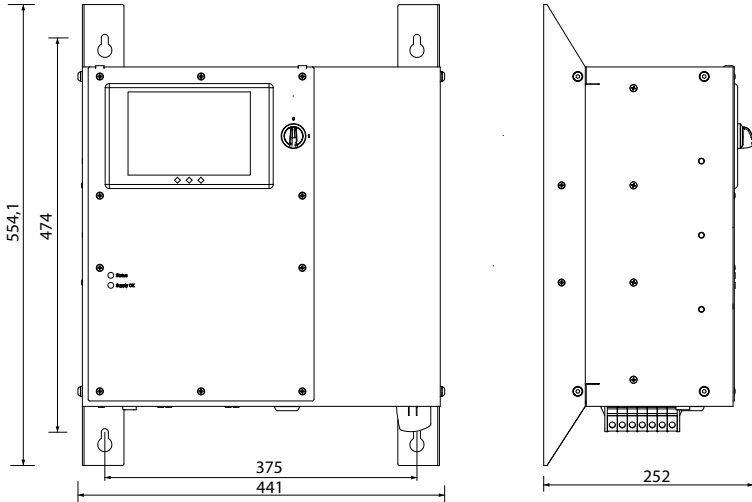

Extension module compact IPU

Extension module (IPU), controlled from main device

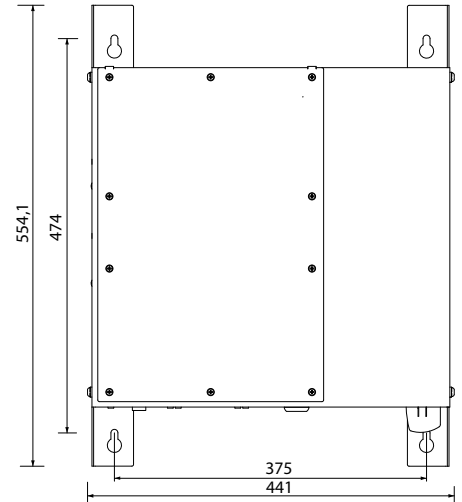

MIO (measurement unit with digital inputs and outputs)
To be installed separately, e.g. in supply section

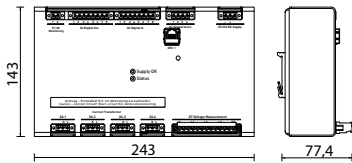

GRIDCON® ACF Building version – power unit (IPU) for separate installation / extension

Wall-mounted installation („book-style“)

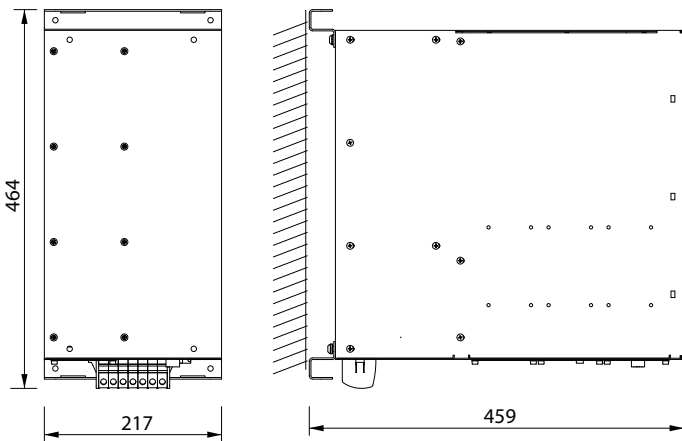

Installation in 19 inch frame (height of 5 RU)

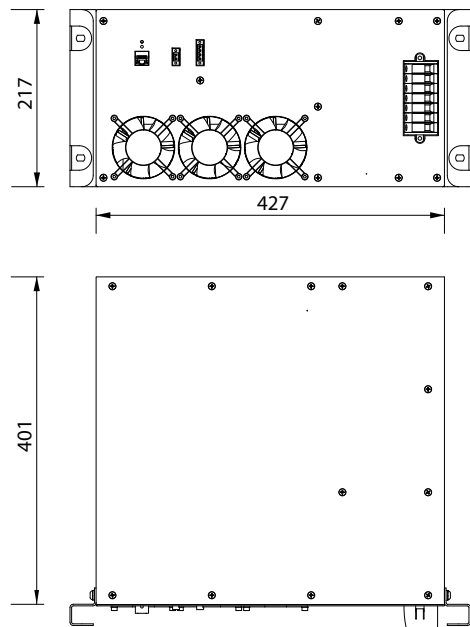

LOW-VOLTAGE SOLUTIONS:

Maschinenfabrik Reinhausen GmbH

Power Quality

Wiebestr. 46

10553 Berlin, Germany

Phone: +49 30 330915-0

Fax: +49 30 330915-25

E-mail: support.pq@reinhausen.com

MEDIUM-VOLTAGE SOLUTIONS:

Maschinenfabrik Reinhausen GmbH

Power Quality

Alte Chaussee 73

99097 Erfurt, Germany

Phone: +49 361 30103-0

Fax: +49 361 30103-20

E-mail: support.pq@reinhausen.com

Maschinenfabrik Reinhausen GmbH

Falkensteinstrasse 8

93059 Regensburg, Germany

Phone: +49 941 4090-0

Fax: +49 941 4090-7001

E-mail: info@reinhausen.com

www.reinhausen.com

Please note:

The data in our publications may differ from the data of the devices delivered. We reserve the right to make changes without notice.

IN4184007/00 EN – GRIDCON® ACF –

F0327500 – 04/16 – uw

©Maschinenfabrik Reinhausen GmbH 2014

THE POWER BEHIND POWER.

