

## Water Cooled Oil Free Centrifugal Chillers



### EWWD~DZ

Nominal capacity range: 320 - 2173 kW

State-of-the-art magnetic bearing compressor with oil-free technology

Economizer available on specific sizes

Compact Footprint - Compact design through stacked heat exchanger layout

Compressor's combination allowing the operation for Dry Cooler and Cooling Tower Applications

Performance according to EN14511

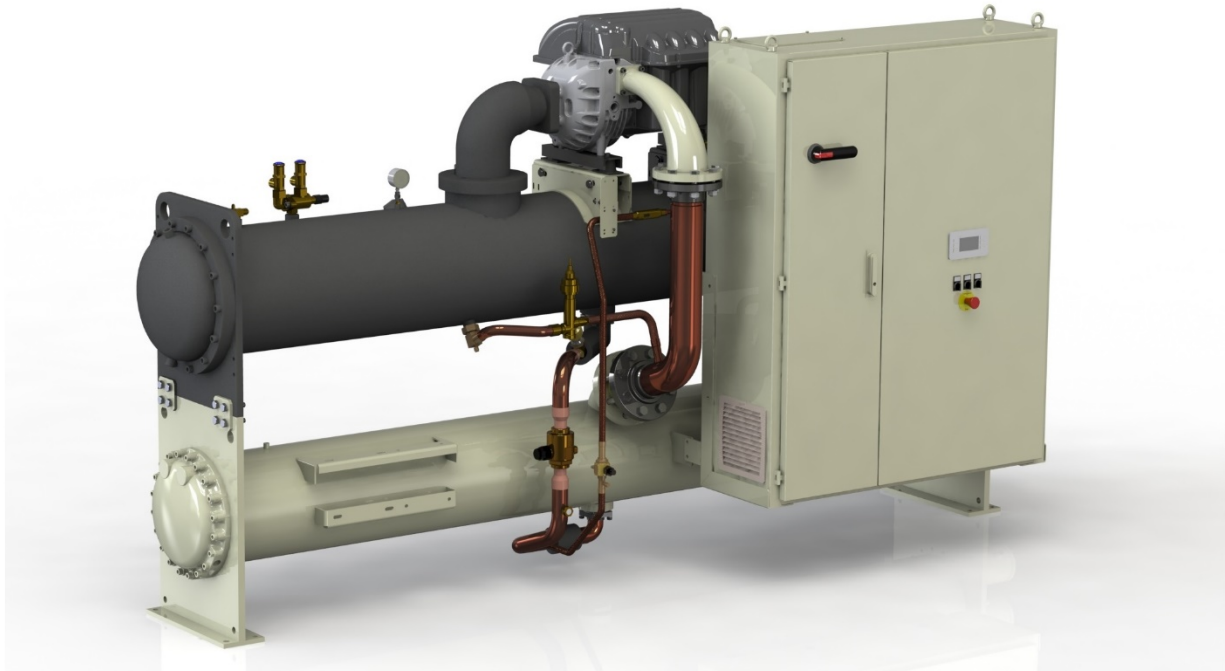

## **FEATURES AND BENEFITS**

**Magnetic Bearing Technology** The EWWD~DZ Series is the new Water Cooled Oil Free Centrifugal chiller fitted with centrifugal compressors utilizing frictionless magnetic bearings for oil-free operation, integrated variable-frequency drives, and high-speed direct drive technology.

**Industry leading part load efficiency** The EWWD~DZ Series is the result of careful design, aimed to optimize the energy efficiency of the chiller and with the clear target to reduce operating costs. The high efficiency compressor is matched with highly efficient heat exchangers to make an impressive chiller.

**Wide range of cooling capacity** The EWWD~DZ Series start from 320 kW up to 1478 kW (full load cooling capacity at Eurovent conditions):

- Single Compressor from 320 up to 742 kW
- Dual Compressors/Single Circuit from 610 kW up to 1478 kW
- Triple Compressors/Single Circuit from 1038 kW up to 2173 kW

**Economized version** On specific sizes, refrigerant circuit is including economizer in order to increase capacity and efficiency.

**Increased reliability** The frictionless magnetic bearing design needs no oil management system, resulting in increased reliability and reduced maintenance. With no oil to coat the heat transfer surfaces, a gain in heat exchanger efficiency can also be realized.

**Compactness** The EWWD~DZ Series is designed to achieve the smallest possible footprint making the product the ideal solution to fit through the tightest doorways and consequently the perfect product for replacement projects.

**Application flexibility** The EWWD~DZ Series will include chillers suitable for both high condensing operation (Dry Cooler application) and low temperature operation (Cooling Tower applications).

**Quiet operation.** Very low sound levels are achieved at part loads thanks to the reduction of compressor rotational speed. Compressor sound proof cabinet option is available to further reduce sound level.

**Extremely low vibration levels** As a result of the high-speed design, the compressor vibration levels are extremely low, minimizing vibration that could be transmitted to the structure.

**Smart refrigerant choice** The compressor is optimized for HFC 134a, the positive pressure refrigerant with no phase-out schedule and no ozone depletion.

**Future readiness.** The EWWD~DZ A series is designed for R134a refrigerant in order to achieve the highest possible unit efficiency. Additionally, to this, it has been designed to be compatible for "drop in" of next generation refrigerants with lower GWP. Daikin is at full disposal to provide further information about this specific subject.

**Superior control logic.** The EWWD~DZ Series is enjoying MicroTech III controller that provides an easy to use control environment. The control logic is designed to provide highest efficiency performances and continuous operation. Easy interface with LonWorks, Bacnet, TCP/IP or Modbus communication protocols.

**Extensive option list** A wide portfolio of options is available to meet different requirements.

**Negligible inrush current.** No any current spike is experienced at start up thanks to inverter driven compressor motors. The starting current is always lower than full load current (FLA).

**Codes and Certifications.** The EWWD~DZ Series is CE marked, complying with European directive in force concerning manufacturing and safety. Units are designed and manufactured in accordance with applicable selections of the following:

- Pressure Equipment Directive 2014/68/EU:
- Machinery Directive 2006/42/EC
- Low Voltage Directive 2014/35/EU
- Electromagnetic Compatibility 2014/30/EU
- Electrical & Safety codes EN60204-1/EN61439-1/EN61439-2
- Manufacturing Quality Standards UNI EN ISO 9001:2004
- Environmental Management System UNI EN ISO 14001:2004
- Health & Safety Management System BS OHSAS 18001:2007

Additional information related to F-GAS Regulation (EU) No 517/2014 of the European Parliament and of the Council of 16th April 2014 on fluorinated greenhouse gases and repealing Regulation (EC) No 842/2006.

	Refrigerant Type	Refrigerant GWP	No. of circuits	Refrigerant Charge circuit 1 [kg]	Refrigerant Charge circuit 1 [TCO2Eq]
EWWD320DZXSA1	R134a	1430	1	120	171.6
EWWD340DZXEA1	R134a	1430	1	130	185.9
EWWD440DZXSA1	R134a	1430	1	120	171.6
EWWD470DZXEA1	R134a	1430	1	130	185.9
EWWD530DZXSA1	R134a	1430	1	120	171.6
EWWD570DZXEA1	R134a	1430	1	130	185.9
EWWD610DZXSA2	R134a	1430	1	120	171.6
EWWD640DZXSA2	R134a	1430	1	130	185.9
EWWD670DZXEA2	R134a	1430	1	120	171.6
EWWD680DZXEA2	R134a	1430	1	130	185.9
EWWD700DZXSA1	R134a	1430	1	180	257.4
EWWD740DZXEA1	R134a	1430	1	190	271.7
EWWD880DZXSA2	R134a	1430	1	180	257.4
EWWD950DZXEA2	R134a	1430	1	200	286
EWWD10DZXSA2	R134a	1430	1	230	328.9
EWWD11DZXEA2	R134a	1430	1	250	357.5
EWWD14DZXSA2	R134a	1430	1	230	328.9
EWWD15DZXEA2	R134a	1430	1	250	357.5
EWWD10DZXEA3	R134a	1430	1	350	500.5
EWWD13DZXSA3	R134a	1430	1	320	457.6
EWWD14DZXEA3	R134a	1430	1	400	572
EWWD15DZXSA3	R134a	1430	1	340	486.2
EWWD17DZXEA3	R134a	1430	1	420	600.6
EWWD21DZXSA3	R134a	1430	1	390	557.7
EWWD22DZXEA3	R134a	1430	1	470	672.1

Note: Equipment contains fluorinated greenhouse gases. Actual refrigerant charge depends on the final unit construction; details can be found on the unit nameplate

**GENERAL CHARACTERISTICS**

**Cabinet and structure.** The cabinet is made of galvanized steel sheet and painted to provide a high resistance to corrosion. Color is Ivory White (Munsell code 5Y7.5/1) (±RAL7044). Unit is fitted with eyehooks for lifting with ropes and for an easy handling. The weight is uniformly distributed along the base’s profiles for a simplified unit installation.

**Oil Free Centrifugal compressor with magnetic bearing.** EWWD-DZ’s exceptional efficiency and reliability is due to its cutting-edge permanent magnet motor and magnetic bearing compressor technology. A digitally-controlled magnetic bearing system replaces conventional oil lubricated bearings and a direct drive motor eliminates the need for a lubricated gear box. The compressor shaft, shown in Figure 1, levitates on a magnetic cushion and is the compressor’s only major moving component. Sensors at each magnetic bearing provide real-time feedback to the bearing control system. As a result of this sophisticated design, EWWD-DZ Series has many advantages over chillers with traditional centrifugal compressors.

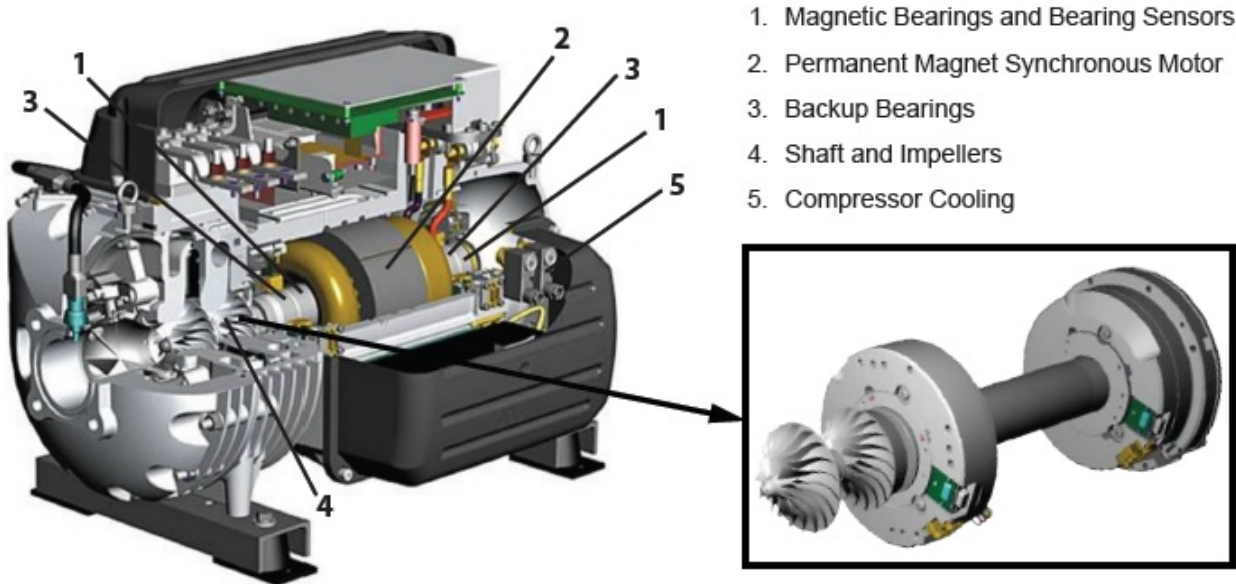

Figure 1 Magnetic bearing compressor

**Oil-Free Compressor Design Benefits**

**No Oil Management System = Greater Reliability**

With magnetic bearings operating in a magnetic field instead of oil-lubricated bearings, the oil handling equipment is removed. No need for:

- oil pumps
- oil reservoirs
- oil coolers
- oil filters
- water regulating valves
- oil relief valves
- oil storage and disposal
- oil system controls, starter, piping, heaters, etc.

that are needed to maintain oil quality. These devices can be a fault source in traditional chillers, and removing them significantly increases unit and system reliability.

**No Oil System = Reduced Maintenance Costs**

With oil removed from the system, oil samples, oil changes, oil system maintenance, oil filter changes, and leaks are eliminated.

**Totally Oil-Free Operation = Greater Efficiency**

The use of oil-free magnetic bearing technology significantly increases chiller efficiency by reducing frictional losses within the bearing system.

In addition, efficiency improvements can be realized since there is no oil to coat the heat transfer surfaces.

**No Oil Loss = Sustainable Performance**

With no possibility of oil loss at light loads or due to worn seals, the original energy saving efficiency can be maintained for the life of the chiller.

**No Oil System = Low Vibration & Sound Levels**

With the use of magnetic bearings, the compressor vibration levels are extremely low, minimizing vibration that could be transmitted to the structure.

With low vibration levels, sound levels are lower compared to traditional centrifugal chillers.

**Integrated Variable Frequency Drive.** Variable Frequency Drive (VFD) modulates compressor speed in response to load and evaporator/condenser pressure. When minimum speed is reached, moveable inlet guide vanes redirect the gas flow into the impeller. VFD's have the following benefits:

- Reduced annual energy costs when there are long periods of part load operation and/or low compressor lift (lower condenser water temperature)
- Reduced motor starting inrush current
- Reduced size of backup generators used to provide emergency power to chillers used on mission critical applications
- Increased power factor to reduce utility surcharges

**Economized refrigerant circuit.** Economizer is available on specific sizes for improved efficiency. An economizer is a well-proven device to increase a refrigerant circuit's capacity and efficiency. Warm liquid from the condenser is fed into the economizer where it is cooled by flashing off liquid also from the condenser. The flash gas is piped to a compressor interstage point. Lowering the liquid refrigerant temperature to the evaporator decreases its enthalpy (heat content) and results in a greater amount of heat absorption from the chilled water.

**Refrigerant.** The EWWD~DZ Series is designed for R134a refrigerant in order to achieve the highest possible unit efficiency.

**Evaporator.** High efficiency flooded type shell and tube heat exchanger. Evaporator tubes have been selected in order to achieve the highest heat transfer. Optimized nucleate boiling is guaranteed by specifically designed cavities on the external tubes' surface. Internal tubes surface area has helical type design. The extremely high heat transfer coefficient allows the reduction of the temperature difference between chilled water and refrigerant thus resulting in higher overall unit efficiency.

The evaporator is designed according to 2014/68/EU European standard (Construction of pressure vessel). The water side is designed for 10 bar maximum operating pressure; vents and drain are provided. Water connections are Victaulic type as standard, flanged connections are available as optional. As standard unit evaporator is two water passes design. Nonstandard applications may require different number of water passes (contact Factory for further information). As standard, thermal insulation (20 mm thickness) is fitted on the external evaporator surface area.

**Condenser.** High efficiency shell and tube type heat exchanger. Condenser tubes have been selected in order to achieve the highest heat transfer. Optimized condensation is achieved by finned type tube external surface area. Internal tubes surface area has helical type design. The extremely high heat transfer coefficient allows the reduction of the temperature difference between condenser water and refrigerant thus resulting in higher overall unit efficiency. The condenser is designed according to 2014/68/EU European standard (Construction of pressure vessel). The water side is designed for 10 bar maximum operating pressure; vents and drain are provided. Water connections are Victaulic type as standard, flanged connections are available as optional. Unit condenser is two water passes design.

**Electronic expansion valve.** Unit is equipped with latest technology electronic expansion valve to achieve precise control of refrigerant mass flow. As today's system requires improved energy efficiency, tighter temperature control and wide operating range, the application of electronic expansion valve is the recommended solution. Electronic expansion valve provides unique features such as short opening and closing times, high resolution, positive shut-off function eliminating the need for additional solenoid valve, continuous modulation of mass flow with reduced stress in the refrigerant circuit.

**Refrigerant Circuit.** Each unit has one refrigerant circuit including:

- 1, 2 or 3 compressors
- Electronic expansion valve
- Evaporator
- Manometers on evaporator and condenser (option)
- Condenser
- Safety valves on evaporator and condenser
- Flow switch on evaporator and condenser (option)

**Electrical control panel** Power and control are located into the main electrical panel IP54 designed. The main panel doors are interlocked to the main switch (standard) in order to guarantee safe operation when doors are opened. The power section includes compressor protection devices.

**MicroTech III Controller.** The MicroTech III control system consists of a microprocessor-based controller and a number of extension modules, which vary depending on the unit size and configuration. The system provides the monitoring and control functions required for an efficient and trouble free operation of the chiller.

A display installed on the outside of the control panel's door allows easy access to chiller operating status including water temperatures and refrigerant pressures and temperatures.

A sophisticated software with predictive logic selects the most energy efficient combination of compressor load and electronic expansion valve position keeping stable operating conditions and maximizing chiller efficiency and reliability.

In addition to normal operating functionalities, MicroTech III controller will take corrective actions in case the chiller operating outside recommended working conditions.

Unit controller is able to protect critical unit components thanks to the signals received by the various unit sensors (such as motor temperature sensors, refrigerant and oil pressure/temperature sensors, pressure switches...etc..).

Main control features are (for more information refer to Unit Control Manual):

- Optimized management of compressors stepless capacity control through inverter drive.
- Display of evaporator entering/leaving water temperatures.
- Display of condenser entering/leaving water temperatures.
- Display of refrigerant condensing/evaporating temperatures and pressures.
- Regulation of leaving evaporator water (cooling mode). Temp. tolerance  $\pm 0,1^{\circ}\text{C}$ .

- Display of compressor working hours and number of compressor starts.
- Re-start in case of power failure (automatic or manual depending on failure type).
- Soft load (optimized management of the compressor load during the start-up).
- Set point reset.
- Master/Slave operation (up to 4 chillers connected).

Alarms signaling (for more information refer to Unit Control Manual):

- Phase loss.
- Evaporator water flow loss.
- Evaporator water freezing protection.
- External alarm.
- Low evaporator refrigerant pressure.
- High refrigerant pressure (transducer).
- High refrigerant discharge temperature.
- High motor temperature.

**Connection to BMS.** The MicroTech III controller is capable to communicate with BMS (Building Management System) based on the most common protocols such as: ModbusRTU, LonWorks, BacNet IP and MS/TP (class 4), Ethernet TCP/IP. Communication modules (optional) are to be selected according to the required communication protocol.

**Master/Slave** The unit is able to operate in Master / Slave mode in order to be connected with other similar unit (up to 4). The master unit manages the slave units connected in series on the hydraulic plant with the aim of optimize the running hours of each compressor and to balance the load between the units.

**App Ready** The unit is able to operate with an App specifically designed to interface the user with the unit controller. App is characterized by and easy-to-access data, and it allows an effective graphical representation of the main figures and displaying the unit operating parameters, accept set-point changes (multi-level password protected) and be capable of resetting faults and alarms.

**Portable touch panel (on request)** The chiller will be provided with a portable touch panel. Portable touch panel will be supplied fitted inside the unit control panel for easy removable configuration. It is provided together with the App already installed allowing a ready connection to the unit controller.

**NOMENCLATURE**

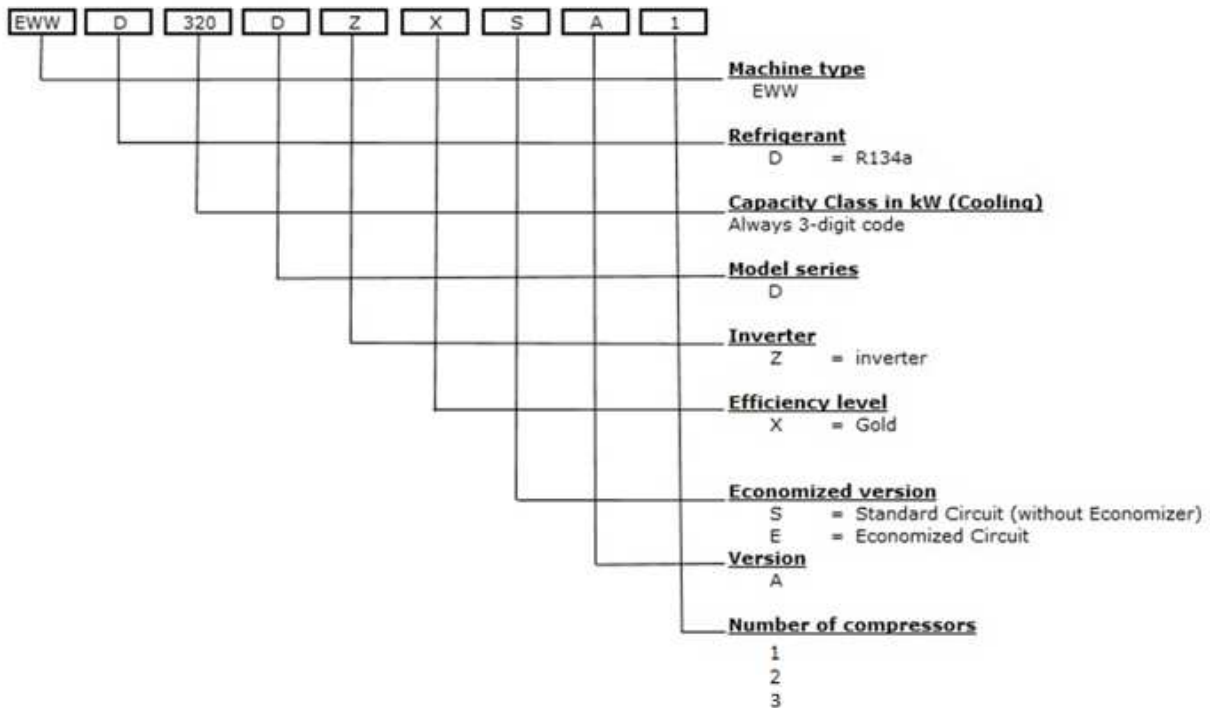

**STANDARD OPTIONS**

**Evaporator Victaulic kit (option 20 - STANDARD).** Victaulic joints and counter-pipes.

**Evaporator water design pressure 10 bar (option 27 – STANDARD).**

**20 mm evaporator insulation (option 29 – STANDARD).** Thermal insulation of the evaporator shell.

**Condenser Victaulic kit (option 36 - STANDARD).** Victaulic joints and counter-pipes. *Opt. incompatibility 26, 38, 50*

**Condenser water design pressure 10 bar (option 47a – STANDARD).**

**Evaporator two passes (option 103a – STANDARD).** Two passes water side design. Refer to unit dimensional drawing for water INLET/OUTLET details. *Opt. incompatibility 22, 103, 103b*

**Condenser two passes (option 52 – STANDARD).** Two passes water side design. Refer to unit dimensional drawing for water INLET/OUTLET details. *Opt. incompatibility 38, 51, 53b*

**Electronic expansion valve (option 60 – STANDARD).**

**Double pressure relief valve with diverter (option 91 – STANDARD).**

**Inverter compressor starter (option 14 – STANDARD).** Electronic device used as starter and for compressor capacity control.

**Current limit (option 19 – STANDARD).** Functionality Included in the compressor inverter device.

**Hour run meter (option 68 – STANDARD).** Standard functionality of unit controller.

**General fault contactor (option 69 – STANDARD).** Standard functionality of unit controller.

**Set point reset, demand limit and alarm from an external device (option 90 – STANDARD).** Standard functionality of unit controller. Set point reset: possibility to re-set the water temperature set point by means of a 4-20 mA signal. Demand Limit: possibility to limit unit capacity by means of 4-20 mA signal. Alarm from external device: unit controller capability to receive an external alarm signal. The user can decide whether this alarm signal will stop the unit controller or not. Refer to unit control manual for more information.

**Main switch interlocked doors (option 97 – STANDARD).** Electrical panel's doors are interlocked with the main switch isolator for safe operation.

**Master/Slave (option 128 – STANDARD).** Standard controller functionality allowing to connect up to 4 units and providing basic sequencing functionalities such as: balancing of working hours of unit & compressors; balancing of unit loads amongst connected units. An additional probe (NTC10K, not provided by Factory) must be installed on the common water header and connected to the master unit.

**Container kit (option 71 – STANDARD)** *Opt. incompatibility 112*

#### **ON REQUEST OPTIONS**

**Evaporator double flanges kit (option 104 – ON REQUEST).** Victaulic-to-flange adapter (shipped loose and including counter-flanges, gaskets and bolts). *Opt. incompatibility 20, 22*

**Condenser double flanges kit (option 26 – ON REQUEST).** Victaulic-to-flange adapter (shipped loose and including counter-flanges, gaskets and bolts). *Opt. incompatibility 36, 38*

**20 mm condenser insulation (option 33 – ON REQUEST).** Thermal insulation of the condenser shell. *Opt. incompatibility 175*

**Discharge line shut off valve (option 61 – ON REQUEST).** Installed on the discharge line of the compressor to facilitate maintenance operations.

**Suction line shut off valve (option 62 – ON REQUEST).** Installed on the suction line of the compressor to facilitate maintenance operations.

**High-pressure side manometers (option 63 – ON REQUEST).**

**Low-pressure side manometers (option 64 – ON REQUEST).**

**Compressor soundproof system (option 76-b – ON REQUEST).** High performance soundproof cabinet installed around compressor and specifically designed in order to minimize unit sound levels.

**Refrigerant leak detection (option 121 – ON REQUEST).** Electronic device (shipped loose) for automatic detection of refrigerant leak. The leak detection device should be installed within the machinery room in the most appropriate location (refer to the leak detection device installation manual). When leak above a pre-set concentration of refrigerant (2000 ppm) is detected, signal is sent to unit controller (a specific alarm is visualized on the unit microprocessor's display). The Factory does not supply interconnecting cables between leak detection device and unit controller.

**Knock down electrical panel (option 147 – ON REQUEST).** Electrical panel dismantled from the unit and shipped separately.

**Compressor thermal insulation (option 146 – ON REQUEST).** Insulation of the compressor's end bell to prevent condensation due to the motor-cooling circuit located on this end of the compressor.

**Nitrogen holding charge on water side heat exchangers (option 170 – ON REQUEST).** Unit is shipped with holding nitrogen charge at 2 bar on water side heat exchangers.

**Cu-Ni 90-10 condenser tubes (option 50 – ON REQUEST).** Condenser tubes made of Cu-Ni 90-10 material and Cu-Ni 90-10 tube sheets cladding. Epoxy ceramic coating of water headers and sacrificial anodes. Unit performances may differ from standard. Contact local Daikin office for more details. When selecting option 50, condenser double flanges kit option (option 26) must be selected as well. *Opt. incompatibility 36, 38*

**Evaporator 3 passes (option 103b – ON REQUEST).** Three passes water side evaporator. May be required in case of evaporator water temperature difference higher than 8°C. Unit performances may differ from standard. Contact local Daikin office for more details. *Opt. incompatibility 22, 103, 103a*

**Evaporator single pass (option 103 – ON REQUEST).** Single pass water side evaporator. May be required in case of evaporator water temperature difference lower than 4°C. Unit performances may differ from standard. Contact local Daikin office for more details. *Opt. incompatibility 22, 103a, 103b*

**Condenser 3 passes (option 53b – ON REQUEST).** Three passes water side evaporator. May be required in case of evaporator water temperature difference higher than 8°C. Unit performances may differ from standard. Contact local Daikin office for more details. *Opt. incompatibility 38, 51, 52*

**Condenser single pass (option 51 – ON REQUEST).** Single pass water side evaporator. May be required in case of evaporator water temperature difference lower than 4°C. Unit performances may differ from standard. Contact local Daikin office for more details. *Opt. incompatibility 38, 52, 53b*

**Evaporator Marine Waterbox (option 22 – ON REQUEST).** Evaporator can be furnished with marine water boxes with victaulic or flanged connections (on request). To save time and work marine water boxes cover can be easily removed to clean internal tubes without the disconnectin of the pipings. *Opt. incompatibility 20, 104*

**Condenser Marine Waterbox (option 38 – ON REQUEST).** Evaporator can be furnished with marine water boxes with victaulic or flanged connections (on request). To save time and work marine water boxes cover can be easily removed to clean internal tubes without the disconnectin of the pipings. *Opt. incompatibility 26, 36, 50*

**Energy meter (option 16 – ON REQUEST).** Electronic device installed within unit electrical panel. Measures and display supply line individual phase voltage and current, active and reactive power input, active and reactive energy consumption. An integrated RS485 module allows Modbus communication to BMS.

**Evaporator flow switch (option 58 – ON REQUEST).** Paddle flow switch shipped loose. Refer to unit installation manual for more details.

**Condenser flow switch (option 59 – ON REQUEST).** Paddle flow switch shipped loose. Refer to unit installation manual for more details.

**Compressor circuit breakers (option 95 – ON REQUEST).** Protection device including protection from current overload and overcurrent. In case this option is selected, compressor fuses are removed.

**Ground fault relay (option 102 – ON REQUEST).** Unit shuts down in case of ground fault is detected.

**Rapid restart (option 110 – ON REQUEST).** Ideal solution for those critical applications that cannot afford the loose of cooling. In case of power failure unit will re-start as fast as 26 seconds from power restoration. Unit will reach full load within 280 seconds and 360 seconds respectively for single compressor and dual compressors unit models. Refer to unit control manual for more information about this option.

**Heat Pump Version (including Pursuit Mode) (option 07a – ON REQUEST).** The Heat Pump Version includes Pursuit Mode and allows reversibility on the water side. Cooling or heating mode operation can be selected by means of a dedicated switch installed on the unit electrical panel. If communication card is selected, cooling or heating mode operation can be managed by BMS. It always includes HGBP and an additional insulation of 20 mm on the condenser. *Opt. incompatibility 175 – 33*

**Hot Gas ByPass-HGBP (option 175 – ON REQUEST).** The hot gas bypass (fig.1) reduces compressor cycling in order to stabilize the chilled water temperature at very low loads. HGBP feeds discharge gas directly into the evaporator when the system load falls below 10% compressor capacity. This hot gas provides a stable refrigerant flow and keeps the chiller from short cycling under reduced load conditions combined with high lift. It also reduces surge potential on heat pump mode units. *Opt. incompatibility 07a*

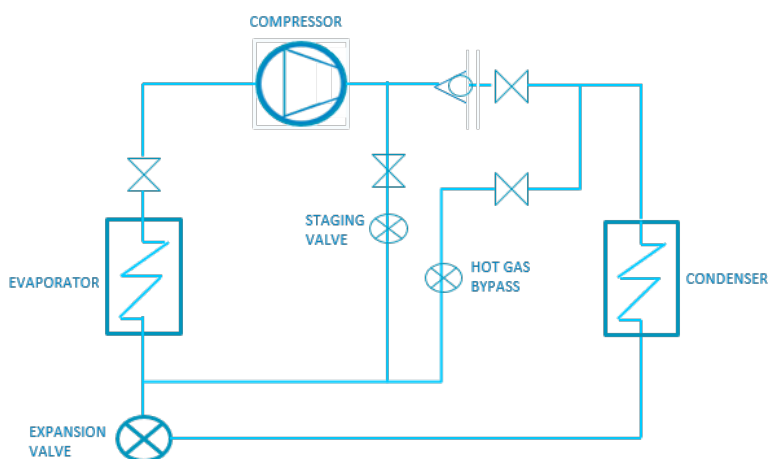

**Fig. 1 Operating scheme of the HGBP**



## TECHNICAL SPECIFICATIONS

MODEL		EWWD320D ZXSA1	EWWD340D ZXEA1	EWWD440D ZXSA1	EWWD470D ZXEA1	EWWD530D ZXSA1	EWWD570D ZXEA1
<b>COOLING PERFORMANCE</b>							
Capacity - Cooling	kW	320	341	443	474	528	566
Capacity control - Type		Stepless	Stepless	Stepless	Stepless	Stepless	Stepless
Capacity control - Minimum capacity	%	30	29	21	20	21	20
Unit power input - Cooling	kW	66.5	69.9	88.5	93.5	102	108
EER		4.81	4.88	5.00	5.07	5.14	5.22
SEER		8.56	8.57	8.05	8.09	8.29	8.34
IPLV		9.68	9.57	9.67	9.62	10.0	10.0
<b>CASING</b>							
Colour *		IW	IW	IW	IW	IW	IW
Material *		GPSS	GPSS	GPSS	GPSS	GPSS	GPSS
<b>DIMENSIONS</b>							
Height	mm	1865	1865	1865	1865	1865	1865
Width	mm	1055	1055	1055	1055	1055	1055
Length	mm	3625	3625	3625	3625	3625	3625
<b>WEIGHT</b>							
Unit Weight	kg	1700	1750	1900	1950	2000	2050
Operating Weight	kg	1973	2033	2216	2276	2347	2407
<b>HEAT EXCHANGER - EVAPORATOR</b>							
Type *		Flooded S&T	Flooded S&T	Flooded S&T	Flooded S&T	Flooded S&T	Flooded S&T
Fluid		Water	Water	Water	Water	Water	Water
Fouling Factor	m <sup>2</sup> °C /W	0	0	0	0	0	0
Water Volume	l	70	70	96	96	107	107
Water temperature in	°C	12	12	12	12	12	12
Water temperature out	°C	7	7	7	7	7	7
Water flow rate	l/s	15.3	16.4	21.2	22.7	25.3	27.1
Water pressure drop	kPa	47.4	54.2	40.6	46.5	45.0	51.5
Insulation material *		CC	CC	CC	CC	CC	CC
<b>HEAT EXCHANGER - CONDENSER</b>							
Type *		S&T	S&T	S&T	S&T	S&T	S&T
Fluid		Water	Water	Water	Water	Water	Water
Fouling Factor	m <sup>2</sup> °C /W	0	0	0	0	0	0
Water Volume	l	83	83	100	100	120	120
Water temperature in	°C	30	30	30	30	30	30
Water temperature out	°C	35	35	35	35	35	35
Water flow rate	l/s	18.3	19.6	25.3	27.0	30.1	32.1
Water pressure drop	kPa	49.2	56.4	59.5	68.4	54.5	62.4
<b>COMPRESSOR</b>							
Type		Centrifugal	Centrifugal	Centrifugal	Centrifugal	Centrifugal	Centrifugal
Oil charge	l	Oil Free	Oil Free	Oil Free	Oil Free	Oil Free	Oil Free
Quantity	No.	1	1	1	1	1	1
<b>SOUND LEVEL**</b>							
Sound Power - Cooling	dB(A)	87.9	87.9	88.9	88.9	89.9	89.9
Sound Pressure level@1m distance - Cooling	dB(A)	69.6	69.6	70.6	70.6	71.6	71.6
<b>REFRIGERANT CIRCUIT</b>							
Refrigerant type		R134a	R134a	R134a	R134a	R134a	R134a
Refrigerant charge	kg	120	130	120	130	120	130
N. of circuits	No.	1	1	1	1	1	1
<b>PIPING CONNECTIONS</b>							
Evaporator water inlet/outlet	mm	139.7	139.7	139.7	139.7	139.7	139.7
Condenser water inlet/outlet	mm	139.7	139.7	139.7	139.7	139.7	139.7

All the performances (Cooling capacity, unit power input and EER) are based on the following conditions: evaporator 12.0/7.0°C; condenser 30.0/35.0°C, unit at full load operation; operating fluid: Water; fouling factor = 0. (\*) IW: Ivory White; GPSS: Galvanized and Painted Steel Sheet; S&T: Shell & Tube; CC: Closed Cell; (\*\*) The values are according to ISO 3744 and are referred to: evaporator 12/7° C, condenser 30/35° C, full load operation.

## TECHNICAL SPECIFICATIONS

MODEL		EWWD610D ZXSA2	EWWD640D ZXSA2	EWWD670D ZXE2	EWWD680D ZXE2	EWWD700D ZXSA1	EWWD740D ZXE1
<b>COOLING PERFORMANCE</b>							
Capacity - Cooling	kW	610	638	670	682	700	742
Capacity control - Type		Stepless	Stepless	Stepless	Stepless	Stepless	Stepless
Capacity control - Minimum capacity	%	16	15	15	15	18	17
Unit power input - Cooling	kW	124.7	131	138.4	138	126	131
EER		4.89	4.85	4.84	4.91	5.53	5.65
SEER		8.81	8.92	8.82	8.96	8.75	8.86
IPLV		9.66	9.78	9.61	9.63	10.1	10.2
<b>CASING</b>							
Colour *		IW	IW	IW	IW	IW	IW
Material *		GPSS	GPSS	GPSS	GPSS	GPSS	GPSS
<b>DIMENSIONS</b>							
Height	mm	1985	1985	1985	1985	1985	1985
Width	mm	1160	1160	1160	1160	1160	1160
Length	mm	3625	3585	3625	3585	3585	3585
<b>WEIGHT</b>							
Unit Weight	kg	2850	2850	2850	2850	2600	2650
Operating Weight	kg	3197	3344	3197	3354	3102	3162
<b>HEAT EXCHANGER - EVAPORATOR</b>							
Type *		Flooded S&T	Flooded S&T	Flooded S&T	Flooded S&T	Flooded S&T	Flooded S&T
Fluid		Water	Water	Water	Water	Water	Water
Fouling Factor	m <sup>2</sup> °C /W	0	0	0	0	0	0
Water Volume	l	107	134	107	134	134	134
Water temperature in	°C	12	12	12	12	12	12
Water temperature out	°C	7	7	7	7	7	7
Water flow rate	l/s	29.1	30.5	32	32.7	33.5	35.6
Water pressure drop	kPa	59.1	51.0	71.4	58.3	61.3	68.7
Insulation material *		CC	CC	CC	CC	CC	CC
<b>HEAT EXCHANGER - CONDENSER</b>							
Type *		S&T	S&T	S&T	S&T	S&T	S&T
Fluid		Water	Water	Water	Water	Water	Water
Fouling Factor	m <sup>2</sup> °C /W	0	0	0	0	0	0
Water Volume	l	120	170	120	170	188	188
Water temperature in	°C	30	30	30	30	30	30
Water temperature out	°C	35	35	35	35	35	35
Water flow rate	l/s	35.1	36.7	38.6	39.1	39.4	41.6
Water pressure drop	kPa	74	46.2	90	52.9	41.6	46.7
<b>COMPRESSOR</b>							
Type		Centrifugal	Centrifugal	Centrifugal	Centrifugal	Centrifugal	Centrifugal
Oil charge	l	Oil Free	Oil Free	Oil Free	Oil Free	Oil Free	Oil Free
Quantity	No.	2	2	2	2	1	1
<b>SOUND LEVEL**</b>							
Sound Power - Cooling	dB(A)	91.1	91	91.1	91	91.1	91.1
Sound Pressure level@1m distance - Cooling	dB(A)	72.6	72.6	72.6	72.6	72.6	72.6
<b>REFRIGERANT CIRCUIT</b>							
Refrigerant type		R134a	R134a	R134a	R134a	R134a	R134a
Refrigerant charge	kg	120	180	120	200	180	190
N. of circuits	No.	1	1	1	1	1	1
<b>PIPING CONNECTIONS</b>							
Evaporator water inlet/outlet	mm	139.7	168.3	139.7	168.3	168.3	168.3
Condenser water inlet/outlet	mm	139.7	168.3	139.7	168.3	168.3	168.3

All the performances (Cooling capacity, unit power input and EER) are based on the following conditions: evaporator 12.0/7.0°C; condenser 30.0/35.0°C, unit at full load operation; operating fluid: Water; fouling factor = 0. (\*) IW: Ivory White; GPSS: Galvanized and Painted Steel Sheet; S&T: Shell & Tube; CC: Closed Cell; (\*\*) The values are according to ISO 3744 and are referred to: evaporator 12/7° C, condenser 30/35° C, full load operation.

## TECHNICAL SPECIFICATIONS

MODEL		EWWD880D ZXSA2	EWWD950D ZXEA2	EWWD10D ZXSA2	EWWD11D ZXEA2	EWWD14D ZXSA2	EWWD15D ZXEA2
<b>COOLING PERFORMANCE</b>							
Capacity - Cooling	kW	883	946	1056	1130	1402	1478
Capacity control - Type		Stepless	Stepless	Stepless	Stepless	Stepless	Stepless
Capacity control - Minimum capacity	%	11	10	11	10	9	9
Unit power input - Cooling	kW	176	186	205	216	256	263
EER		5.01	5.08	5.15	5.23	5.46	5.60
SEER		8.95	9.00	9.27	9.32	9.26	9.35
IPLV		9.86	9.79	10.2	10.1	10.5	10.4
<b>CASING</b>							
Colour *		IW	IW	IW	IW	IW	IW
Material *		GPSS	GPSS	GPSS	GPSS	GPSS	GPSS
<b>DIMENSIONS</b>							
Height	mm	1985	1985	2200	2200	2200	2200
Width	mm	1160	1160	1270	1270	1270	1270
Length	mm	3585	3585	3580	3580	3580	3580
<b>WEIGHT</b>							
Unit Weight	kg	2900	3000	3600	3700	3800	3900
Operating Weight	kg	3458	3568	4292	4412	4579	4699
<b>HEAT EXCHANGER - EVAPORATOR</b>							
Type *		Flooded S&T	Flooded S&T	Flooded S&T	Flooded S&T	Flooded S&T	Flooded S&T
Fluid		Water	Water	Water	Water	Water	Water
Fouling Factor	m <sup>2</sup> °C /W	0	0	0	0	0	0
Water Volume	l	156	156	199	199	229	229
Water temperature in	°C	12	12	12	12	12	12
Water temperature out	°C	7	7	7	7	7	7
Water flow rate	l/s	42.3	45.3	50.6	54.1	67.2	70.9
Water pressure drop	kPa	64.0	73.2	60.4	68.9	74.0	82.0
Insulation material *		CC	CC	CC	CC	CC	CC
<b>HEAT EXCHANGER - CONDENSER</b>							
Type *		S&T	S&T	S&T	S&T	S&T	S&T
Fluid		Water	Water	Water	Water	Water	Water
Fouling Factor	m <sup>2</sup> °C /W	0	0	0	0	0	0
Water Volume	l	211	211	263	263	320	320
Water temperature in	°C	30	30	30	30	30	30
Water temperature out	°C	35	35	35	35	35	35
Water flow rate	l/s	50.5	53.9	60.1	64.1	79.1	83.0
Water pressure drop	kPa	50.9	58.3	50.3	57.6	52.9	58.5
<b>COMPRESSOR</b>							
Type		Centrifugal	Centrifugal	Centrifugal	Centrifugal	Centrifugal	Centrifugal
Oil charge	l	Oil Free	Oil Free	Oil Free	Oil Free	Oil Free	Oil Free
Quantity	No.	2	2	2	2	2	2
<b>SOUND LEVEL**</b>							
Sound Power - Cooling	dB(A)	92	92	93.3	93.3	94.3	94.3
Sound Pressure level@1m distance - Cooling	dB(A)	73.6	73.6	74.6	74.6	75.6	75.6
<b>REFRIGERANT CIRCUIT</b>							
Refrigerant type		R134a	R134a	R134a	R134a	R134a	R134a
Refrigerant charge	kg	180	200	230	250	230	250
N. of circuits	No.	1	1	1	1	1	1
<b>PIPING CONNECTIONS</b>							
Evaporator water inlet/outlet	mm	168.3	168.3	219.1	219.1	219.1	219.1
Condenser water inlet/outlet	mm	168.3	168.3	168.3	168.3	219.1	219.1

All the performances (Cooling capacity, unit power input and EER) are based on the following conditions: evaporator 12.0/7.0°C; condenser 30.0/35.0°C, unit at full load operation; operating fluid: Water; fouling factor = 0. (\*) IW: Ivory White; GPSS: Galvanized and Painted Steel Sheet; S&T: Shell & Tube; CC: Closed Cell; (\*\*) The values are according to ISO 3744 and are referred to: evaporator 12/7° C, condenser 30/35° C, full load operation.

## TECHNICAL SPECIFICATIONS

MODEL		EWWD10 DZXA3	EWWD13 DZXA3	EWWD14 DZXA3	EWWD15 DZXA3	EWWD17 DZXA3	EWWD21 DZXA3	EWWD22 DZXA3
<b>COOLING PERFORMANCE</b>								
Capacity - Cooling	kW	1038	1325	1437	1565	1685	2070	2173
Capacity control - Type		Stepless	Stepless	Stepless	Stepless	Stepless	Stepless	Stepless
Capacity control - Minimum capacity	%	10	7	7	8	7	6	6
Unit power input - Cooling	kW	210	272	288	311	329	391	393
EER		4.94	4.88	4.98	5.04	5.12	5.3	5.53
SEER		8.57	8.82	8.84	9.09	9.05	9.21	9.33
IPLV		8.41	9.26	9.19	9.53	9.26	9.19	9.3
<b>CASING</b>								
Colour *		IW	IW	IW	IW	IW	IW	IW
Material *		GPSS	GPSS	GPSS	GPSS	GPSS	GPSS	GPSS
<b>DIMENSIONS</b>								
Height	mm	2082	2083	2083	2225	2225	2290	2290
Width	mm	1510	1510	1510	1510	1510	1510	1510
Length	mm	4688	4793	4793	4768	4768	4812	4812
<b>WEIGHT</b>								
Unit Weight	kg	4400	4350	4700	4750	5100	5550	5900
Operating Weight	kg	4970	5020	5370	5540	5890	6570	6920
<b>HEAT EXCHANGER - EVAPORATOR</b>								
Type *		Flooded S&T	Flooded S&T	Flooded S&T	Flooded S&T	Flooded S&T	Flooded S&T	Flooded S&T
Fluid		Water	Water	Water	Water	Water	Water	Water
Fouling Factor	m <sup>2</sup> °C /W	0	0	0	0	0	0	0
Water Volume	l	207.3	271.8	271.8	317.4	317.4	444.3	444.3
Water temperature in	°C	12	12	12	12	12	12	12
Water temperature out	°C	7	7	7	7	7	7	7
Water flow rate	l/s	49.1	63.4	68	74.9	80.4	99.1	103
Water pressure drop	kPa	61.4	60.1	70.7	61.1	70.7	71.9	78.9
Insulation material *		CC	CC	CC	CC	CC	CC	CC
<b>HEAT EXCHANGER - CONDENSER</b>								
Type *		S&T	S&T	S&T	S&T	S&T	S&T	S&T
Fluid		Water	Water	Water	Water	Water	Water	Water
Fouling Factor	m <sup>2</sup> °C /W	0	0	0	0	0	0	0
Water Volume	l	326.4	359.9	359.9	442.6	442.6	603.6	603.6
Water temperature in	°C	30	30	30	30	30	30	30
Water temperature out	°C	35	35	35	35	35	35	35
Water flow rate	l/s	58.9	76.1	81.4	89.5	95.8	117	121
Water pressure drop	kPa	44	56	66	43	50	57	62
<b>COMPRESSOR</b>								
Type		Centrifugal	Centrifugal	Centrifugal	Centrifugal	Centrifugal	Centrifugal	Centrifugal
Oil charge	l	Oil Free	Oil Free	Oil Free	Oil Free	Oil Free	Oil Free	Oil Free
Quantity	No.	3	3	3	3	3	3	3
<b>SOUND LEVEL**</b>								
Sound Power - Cooling	dB(A)	98	99	99	100	100	101	101
Sound Pressure level @1m distance - Cooling	dB(A)	79	80	80	81	81	82	82
<b>REFRIGERANT CIRCUIT</b>								
Refrigerant type		R-134a	R-134a	R-134a	R-134a	R-134a	R-134a	R-134a
Refrigerant charge	kg	350	320	400	340	420	390	470
N. of circuits	No.	1	1	1	1	1	1	1
<b>PIPING CONNECTIONS</b>								
Evaporator water inlet/outlet	mm	168.3	219.1	219.1	219.1	219.1	219.1	219.1
Condenser water inlet/outlet	mm	168.3	168.3	168.3	219.1	219.1	219.1	219.1

All the performances (Cooling capacity, unit power input and EER) are based on the following conditions: evaporator 12.0/7.0°C; condenser 30.0/35.0°C, unit at full load operation; operating fluid: Water; fouling factor = 0. (\*) IW: Ivory White; GPSS: Galvanized and Painted Steel Sheet; S&T: Shell & Tube; CC: Closed Cell; (\*\*) The values are according to ISO 3744 and are referred to: evaporator 12/7° C, condenser 30/35° C, full load operation.

## ELECTRICAL SPECIFICATIONS

MODEL		EWWD320D ZXSA1	EWWD340D ZXEA1	EWWD440D ZXSA1	EWWD470D ZXEA1	EWWD530D ZXSA1	EWWD570D ZXEA1
<b>POWER SUPPLY</b>							
Phases	No.	3	3	3	3	3	3
Frequency	Hz	50	50	50	50	50	50
Voltage	V	400	400	400	400	400	400
Voltage tolerance Minimum	%	-10%	-10%	-10%	-10%	-10%	-10%
Voltage tolerance Maximum	%	10%	10%	10%	10%	10%	10%
<b>UNIT</b>							
Maximum inrush current	A	0	0	0	0	0	0
Nominal running current cooling	A	100.55	105.42	138.22	144.7	155.23	162.48
Maximum running current	A	134	134	208	208	166	166
Maximum current for wires sizing	A	147	147	229.24	229.24	182.07	182.07
<b>COMPRESSORS</b>							
Phases	No.	3	3	3	3	3	3
Voltage	V	400	400	400	400	400	400
Voltage tolerance Minimum	%	-10%	-10%	-10%	-10%	-10%	-10%
Voltage tolerance Maximum	%	10%	10%	10%	10%	10%	10%
Maximum running current	A	0	0	0	0	0	0
Starting method		VFD	VFD	VFD	VFD	VFD	VFD

MODEL		EWWD610D ZXSA2	EWWD640D ZXSA2	EWWD670D ZXEA2	EWWD680D ZXEA2	EWWD700D ZXSA1	EWWD740D ZXEA1
<b>POWER SUPPLY</b>							
Phases	No.	3	3	3	3	3	3
Frequency	Hz	50	50	50	50	50	50
Voltage	V	400	400	400	400	400	400
Voltage tolerance Minimum	%	-10%	-10%	-10%	-10%	-10%	-10%
Voltage tolerance Maximum	%	10%	10%	10%	10%	10%	10%
<b>UNIT</b>							
Maximum inrush current	A	0	0	0	0	0	0
Nominal running current cooling	A	203.41	200.56	212.9	210.15	190.23	196
Maximum running current	A	267	267	267	267	196	196
Maximum current for wires sizing	A	294	294	294	294	215.6	215.6
<b>COMPRESSORS</b>							
Phases	No.	3	3	3	3	3	3
Voltage	V	400	400	400	400	400	400
Voltage tolerance Minimum	%	-10%	-10%	-10%	-10%	-10%	-10%
Voltage tolerance Maximum	%	10%	10%	10%	10%	10%	10%
Maximum running current	A	0	0	0	0	0	0
Starting method		VFD	VFD	VFD	VFD	VFD	VFD

Allowed voltage tolerance  $\pm 10\%$ . Voltage unbalance between phases must be within  $\pm 3\%$ . In case of inverter driven units, no inrush current at start up is experienced. Nominal running current in cooling is referred to the following conditions: evaporator 12/7°C; condenser 30/35°C. Maximum running current is based on max compressor absorbed current in its envelope. Maximum current for wires sizing is based on minimum allowed voltage. Maximum current for wires sizing: compressors full load ampere x 1,1. The data are referred to the standard unit without options. All data are subject to change without notice. Please refer to unit nameplate data

## ELECTRICAL SPECIFICATIONS

MODEL		EWWD880D ZXSA2	EWWD950D ZXEA2	EWWD10D ZXSA2	EWWD11D ZXEA2	EWWD14D ZXSA2	EWWD15D ZXEA2
<b>POWER SUPPLY</b>							
Phases	No.	3	3	3	3	3	3
Frequency	Hz	50	50	50	50	50	50
Voltage	V	400	400	400	400	400	400
Voltage tolerance Minimum	%	-10%	-10%	-10%	-10%	-10%	-10%
Voltage tolerance Maximum	%	10%	10%	10%	10%	10%	10%
<b>UNIT</b>							
Maximum inrush current	A	0	0	0	0	0	0
Nominal running current cooling	A	274.86	287.44	309.17	323.53	383.87	392
Maximum running current	A	417	417	331	331	392	392
Maximum current for wires sizing	A	458.48	458.48	364.13	364.13	431.2	431.2
<b>COMPRESSORS</b>							
Phases	No.	3	3	3	3	3	3
Voltage	V	400	400	400	400	400	400
Voltage tolerance Minimum	%	-10%	-10%	-10%	-10%	-10%	-10%
Voltage tolerance Maximum	%	10%	10%	10%	10%	10%	10%
Maximum running current	A	0	0	0	0	0	0
Starting method		VFD	VFD	VFD	VFD	VFD	VFD

MODEL		EWWD10 DZXEA3	EWWD13 DZXEA3	EWWD13 DZXSA3	EWWD15 DZXSA3	EWWD17 DZXEA3	EWWD21 DZXSA3	EWWD22 DZXEA3
<b>POWER SUPPLY</b>								
Phases	No.	3	3	3	3	3	3	3
Frequency	Hz	50	50	50	50	50	50	50
Voltage	V	400	400	400	400	400	400	400
Voltage tolerance Minimum	%	-10%	-10%	-10%	-10%	-10%	-10%	-10%
Voltage tolerance Maximum	%	10%	10%	10%	10%	10%	10%	10%
<b>UNIT</b>								
Maximum inrush current	A	0	0	0	0	0	0	0
Nominal running current cooling	A	318.3	425.9	445	471.7	496	588	588
Maximum running current	A	406	631	631	511	511	589	589
Maximum current for wires sizing	A	447	694	694	562	562	648	648
<b>COMPRESSORS</b>								
Phases	No.	3	3	3	3	3	3	3
Voltage	V	400	400	400	400	400	400	400
Voltage tolerance Minimum	%	-10%	-10%	-10%	-10%	-10%	-10%	-10%
Voltage tolerance Maximum	%	10%	10%	10%	10%	10%	10%	10%
Maximum running current	A	0	0	0	0	0	0	0
Starting method		VFD	VFD	VFD	VFD	VFD	VFD	VFD

Allowed voltage tolerance  $\pm 10\%$ . Voltage unbalance between phases must be within  $\pm 3\%$ . In case of inverter driven units, no inrush current at start up is experienced. Nominal running current in cooling is referred to the following conditions: evaporator 12/7°C; condenser 30/35°C. Maximum running current is based on max compressor absorbed current in its envelope. Maximum current for wires sizing is based on minimum allowed voltage. Maximum current for wires sizing: compressors full load ampere x 1,1. The data are referred to the standard unit without options. All data are subject to change without notice. Please refer to unit nameplate data.

**SOUND LEVELS**

MODEL	Sound pressure level at 1 m from the unit (rif. 2 x 10 <sup>-5</sup> Pa)									Power db
	63 Hz	125 Hz	250 Hz	500 Hz	1000 Hz	2000 Hz	4000 Hz	8000 Hz	db(A)	(A)
<b>EWWD320DZXSA1</b>	50.3	51.9	60.2	59.7	63.1	58.8	60.6	67.0	<b>69.6</b>	<b>87.9</b>
<b>EWWD340DZXEA1</b>	50.3	51.9	60.2	59.7	63.1	58.8	60.6	67.0	<b>69.6</b>	<b>87.9</b>
<b>EWWD440DZXSA1</b>	51.3	52.9	61.2	60.7	64.1	59.8	61.6	68.0	<b>70.6</b>	<b>88.9</b>
<b>EWWD470DZXEA1</b>	51.3	52.9	61.2	60.7	64.1	59.8	61.6	68.0	<b>70.6</b>	<b>88.9</b>
<b>EWWD530DZXSA1</b>	52.3	53.9	62.2	61.7	65.1	60.8	62.6	69.0	<b>71.6</b>	<b>89.9</b>
<b>EWWD570DZXEA1</b>	52.3	53.9	62.2	61.7	65.1	60.8	62.6	69.0	<b>71.6</b>	<b>89.9</b>
<b>EWWD610DZXSA2</b>	53.3	54.9	63.2	62.7	66.1	61.8	63.6	70.0	<b>72.6</b>	<b>91.1</b>
<b>EWWD640DZXSA2</b>	53.3	54.9	63.2	62.7	66.1	61.8	63.6	70.0	<b>72.6</b>	<b>91</b>
<b>EWWD670DZXEA2</b>	53.3	54.9	63.2	62.7	66.1	61.8	63.6	70.0	<b>72.6</b>	<b>91.1</b>
<b>EWWD680DZXEA2</b>	53.3	54.9	63.2	62.7	66.1	61.8	63.6	70.0	<b>72.6</b>	<b>91</b>
<b>EWWD700DZXSA1</b>	53.3	54.9	63.2	62.7	66.1	61.8	63.6	70.0	<b>72.6</b>	<b>91.1</b>
<b>EWWD740DZXEA1</b>	53.3	54.9	63.2	62.7	66.1	61.8	63.6	70.0	<b>72.6</b>	<b>91.1</b>
<b>EWWD880DZXSA2</b>	54.3	55.9	64.2	63.7	67.1	62.8	64.6	71.0	<b>73.6</b>	<b>92</b>
<b>EWWD950DZXEA2</b>	54.3	55.9	64.2	63.7	67.1	62.8	64.6	71.0	<b>73.6</b>	<b>92</b>
<b>EWWDC10DZXSA2</b>	55.3	56.9	65.2	64.7	68.1	63.8	65.6	72.0	<b>74.6</b>	<b>93.3</b>
<b>EWWDC11DZXEA2</b>	55.3	56.9	65.2	64.7	68.1	63.8	65.6	72.0	<b>74.6</b>	<b>93.3</b>
<b>EWWDC14DZXSA2</b>	56.3	57.9	66.2	65.7	69.1	64.8	66.6	73.0	<b>75.6</b>	<b>94.3</b>
<b>EWWDC15DZXEA2</b>	56.3	57.9	66.2	65.7	69.1	64.8	66.6	73.0	<b>75.6</b>	<b>94.3</b>
<b>EWWDC10DZXEA3</b>	59.4	60.9	69.2	68.8	72.1	67.8	69.6	76.1	<b>78.6</b>	<b>97.9</b>
<b>EWWDC13DZXSA3</b>	60.4	61.9	70.2	69.8	73.1	68.8	70.6	77.1	<b>79.6</b>	<b>99.0</b>
<b>EWWDC14DZXEA3</b>	60.4	61.9	70.2	69.8	73.1	68.8	70.6	77.1	<b>79.6</b>	<b>99.0</b>
<b>EWWDC15DZXSA3</b>	61.4	62.9	71.2	70.8	74.1	69.8	71.6	78.1	<b>80.6</b>	<b>100.1</b>
<b>EWWDC17DZXEA3</b>	61.4	62.9	71.2	70.8	74.1	69.8	71.6	78.1	<b>80.6</b>	<b>100.1</b>
<b>EWWDC21DZXSA3</b>	62.4	63.9	72.2	71.8	75.1	70.8	72.6	79.1	<b>81.6</b>	<b>101.2</b>
<b>EWWDC22DZXEA3</b>	62.4	63.9	72.2	71.8	75.1	70.8	72.6	79.1	<b>81.6</b>	<b>101.2</b>

The values are according to ISO 3744 and are referred to: evaporator 12/7° C, condenser 30/35° C, full load operation.

**OPERATING LIMITS**

**EWWD-DZ - High condensing operating range**

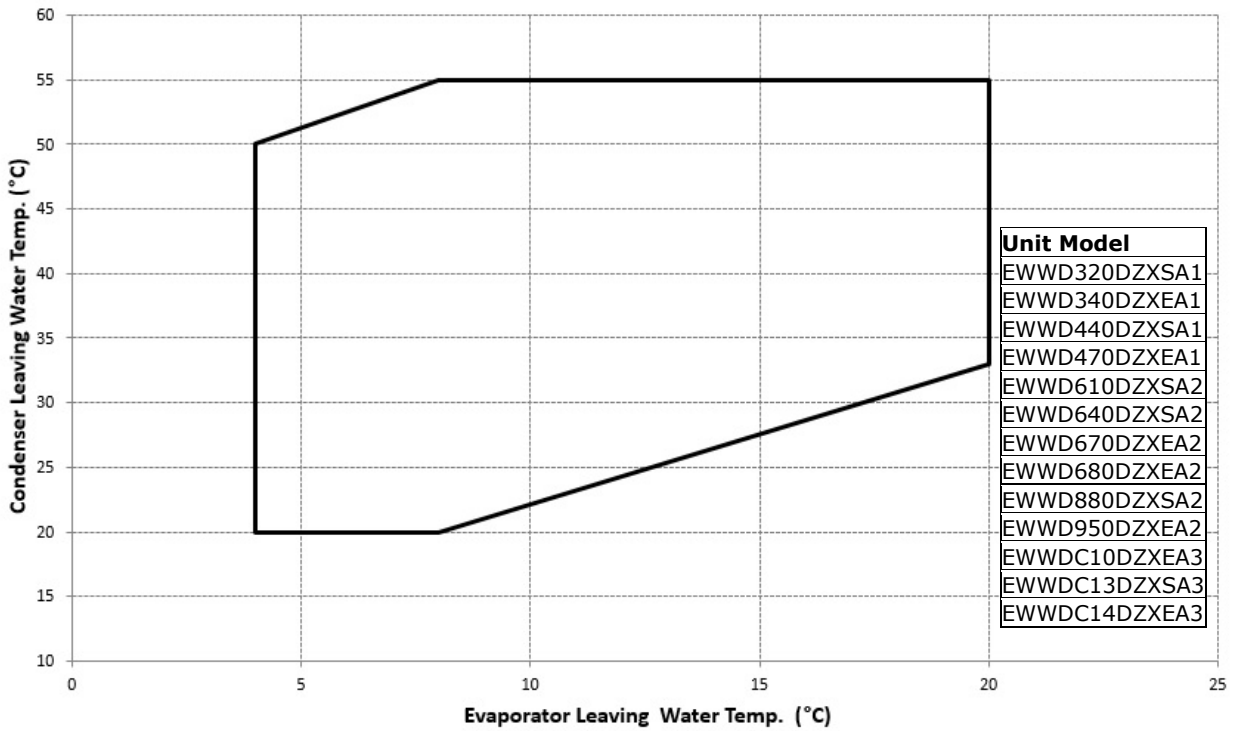

Notes:

- The above graph refers to the unit operating at full load. Unit may be able to operate outside the above envelope with compressors unloading. Please contact factory for further details.
- The above graphic represents a guideline about the operating limits of the range. Please refer to the latest Chiller Selection Software (CSS) for real operating limits working conditions for each size.

**EWWD-DZ - Low condensing operating range**

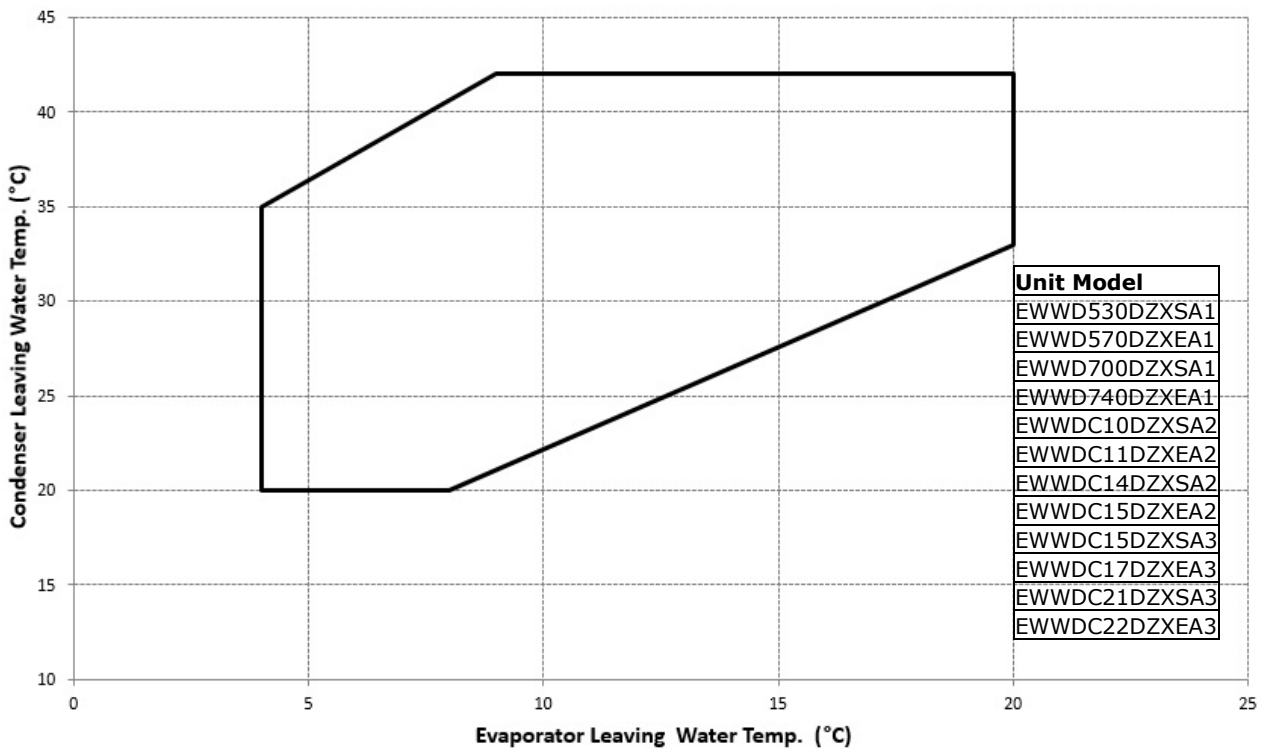



Notes:

- The above graph refers to the unit operating at full load. Unit may be able to operate outside the above envelope with compressors unloading. Please contact factory for further details.
- The above graphic represents a guideline about the operating limits of the range. Please refer to the latest Chiller Selection Software (CSS) for real operating limits working conditions for each size.

**Water heat exchangers - maximum/maximum water  $\Delta t$**

The minimum and maximum allowed  $\Delta t$  at full load conditions are respectively 4°C and 8°C. Contact factory in case lower or higher  $\Delta t$  are required.

**Requirements for operation and storage**

Unit is designed for indoor installation only.

Environmental conditions must be within the following limits:

Limits for operation:

- Maximum ambient temperature: 42°C
- Minimum ambient temperature: 5°C
- Maximum relative humidity: 95% not condensing

Limits for storage:

- Maximum ambient temperature: 55°C
- Minimum ambient temperature: 5°C
- Maximum relative humidity: 95% not condensing

Storage below the minimum temperature may cause damage to components.

Storage above the maximum temperature causes opening of safety valves.

Storage in condensing atmosphere may damage electronic components.

**Water treatment**

Before putting the unit into operation, clean the water circuit. Dirt, scales, corrosion debris and other materials can accumulate inside the heat exchanger and reduce its heat exchanging capacity. Pressure drops can increase as well, thus reducing water flow. Proper water treatment therefore reduces the risk of corrosion, erosion, scaling, etc.. The most appropriate water treatment must be determined locally, according to the type of system and water characteristics. The manufacturer is not responsible for damage to or malfunctioning of equipment caused by improperly treated water.

# Water charge, flow and quality

Items (1) (5)	Cooling Water				Cooled Water		Heated water (2)				Tendency if out of criteria	
	Circulating System		Once Flow	Circulating water		Supply water (4)	Low temperature		High temperature			
	Circulating water	Supply water (4)	Flowing water	[Below 20°C]	Supply water (4)	Circulating water [20°C ~ 60°C]	Supply water (4)	Circulating water [60°C ~ 80°C]	Supply water (4)			
Items to be controlled:	pH	6.5 ~ 8.2	6.0 ~ 8.0	6.0 ~ 8.0	6.0 ~ 8.0	6.0 ~ 8.0	7.0 ~ 8.0	7.0 ~ 8.0	7.0 ~ 8.0	7.0 ~ 8.0	Corrosion + Scale	
	Electrical conductivity	[mS/m] at 25°C	Below 80	Below 40	Below 40	Below 30	Below 30	Below 30	Below 30	Below 30	Below 30	Corrosion + Scale
		[µS/cm] at 25°C	(Below 800)	(Below 400)	(Below 400)	(Below 300)	(Below 300)	(Below 300)	(Below 300)	(Below 300)	(Below 300)	Corrosion + Scale
	Chloride ion	[mgCl <sup>-</sup> /l]	Below 200	Below 50	Below 50	Below 50	Below 50	Below 50	Below 30	Below 30	Below 30	Corrosion
		[mgSO <sub>4</sub> <sup>2-</sup> /l]	Below 200	Below 50	Below 50	Below 50	Below 50	Below 50	Below 30	Below 30	Below 30	Corrosion
	M-alkalinity (pH4.8)	[mgCaCO <sub>3</sub> /l]	Below 100	Below 50	Below 50	Below 50	Below 50	Below 50	Below 50	Below 50	Below 50	Scale
		[mgCaCO <sub>3</sub> /l]	Below 200	Below 70	Below 70	Below 70	Below 70	Below 70	Below 70	Below 70	Below 70	Scale
	Total hardness	[mgCaCO <sub>3</sub> /l]	Below 150	Below 50	Below 50	Below 50	Below 50	Below 50	Below 50	Below 50	Below 50	Scale
		[mgCaCO <sub>3</sub> /l]	Below 50	Below 30	Below 30	Below 30	Below 30	Below 30	Below 30	Below 30	Below 30	Scale
	Silica ion	[mgSiO <sub>2</sub> /l]	Below 1.0	Below 1.0	Below 1.0	Below 1.0	Below 1.0	Below 1.0	Below 1.0	Below 1.0	Below 1.0	Corrosion + Scale
[mgFe/l]		Below 0.3	Below 0.1	Below 0.1	Below 0.1	Below 0.1	Below 0.1	Below 0.1	Below 0.1	Below 0.1	Corrosion	
Copper	[mgCu/l]	Not detectable	Not detectable	Not detectable	Not detectable	Not detectable	Not detectable	Not detectable	Not detectable	Not detectable	Corrosion	
	[mgS <sup>2-</sup> /l]	Not detectable	Not detectable	Not detectable	Not detectable	Not detectable	Not detectable	Not detectable	Not detectable	Not detectable	Corrosion	
Ammonium ion	[mgNH <sub>4</sub> <sup>+</sup> /l]	Below 1.0	Below 0.1	Below 0.1	Below 0.1	Below 0.1	Below 0.3	Below 0.1	Below 0.1	Below 0.1	Corrosion	
	[mgCL/l]	Below 0.3	Below 0.3	Below 0.3	Below 0.3	Below 0.3	Below 0.25	Below 0.1	Below 0.1	Below 0.3	Corrosion	
Remaining chloride	[mgCL/l]	Below 4.0	Below 4.0	Below 4.0	Below 4.0	Below 4.0	Below 0.4	Below 0.4	Below 0.4	Below 4.0	Corrosion	
	[mgCO <sub>2</sub> /l]	6.0 ~ 7.0	---	---	---	---	---	---	---	---	Corrosion + Scale	
Stability index												

1 Names, definitions and units are according to JIS K 0101. Units and figures between brackets are old units published as reference only.

2 In case of using heated water (more than 40°C), corrosion is generally noticeable.

Especially when the iron materials is in direct contact with water without any protection shields, it is desirable to give the valid measure for corrosion. E.g. chemical measure

3 In the cooling water using hermetic cooling tower, close circuit water is according to heated water standard, and scattered water is according to cooling water standard.

4 Supply water is considered drink water, industrial water and ground water except for genuine water, neutral water and soft water.

5 The above mentioned items are representable items in corrosion and scale cases.

**DIMENSIONAL DRAWINGS**

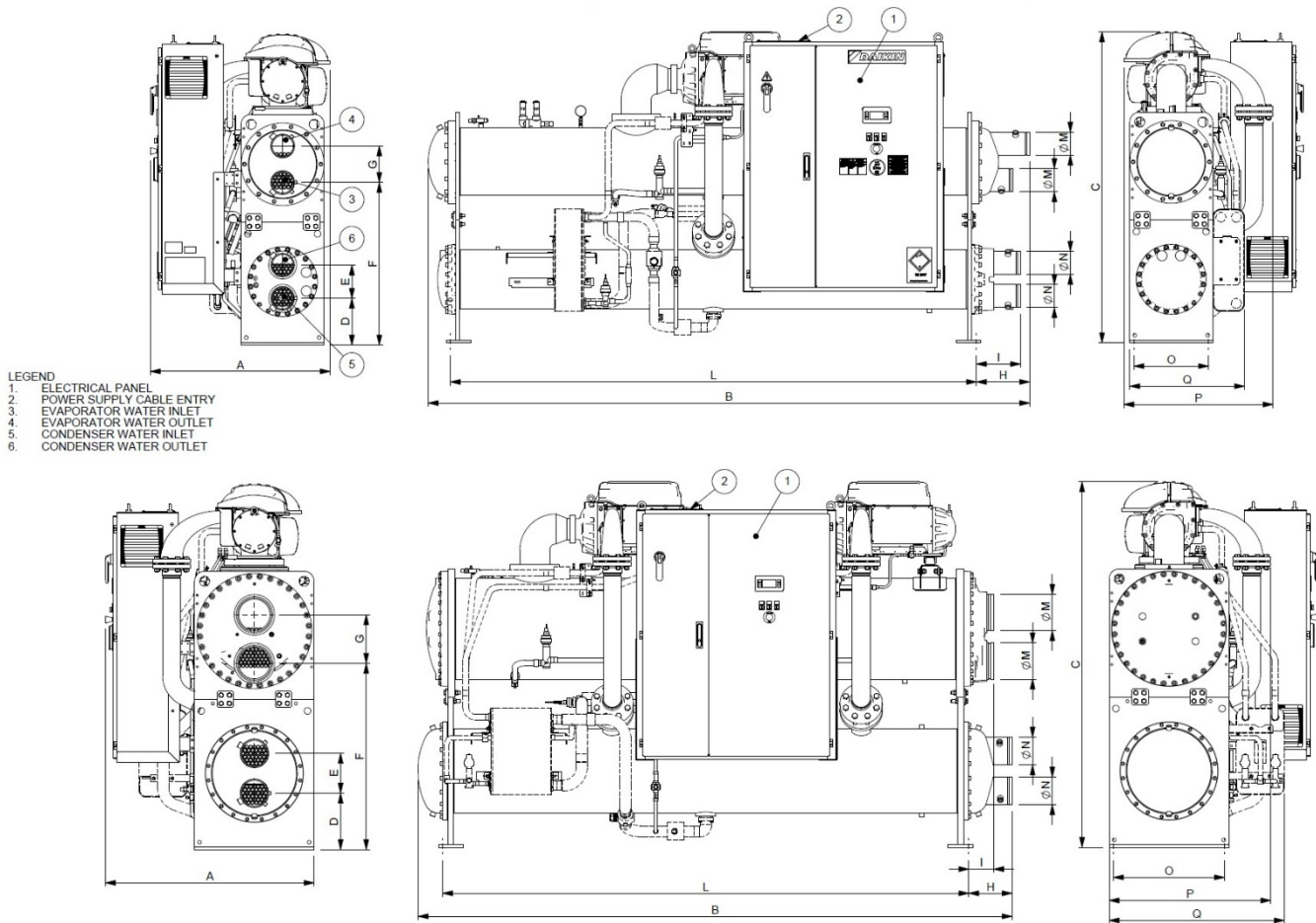

	A	B	C	D	E	F	G	H	I	L	M	N	O	P	Q
EWWD320DZXSA1	1082	3624	1871	281	200	978	220	320	265	3170	139.7	139.7	450	899	-
EWWD340DZXE1	1082	3624	1871	281	200	978	220	320	265	3170	139.7	139.7	450	899	727
EWWD440DZXSA1	1082	3624	1871	281	200	978	220	320	265	3170	139.7	139.7	450	899	-
EWWD470DZXE1	1082	3624	1871	281	200	978	220	320	265	3170	139.7	139.7	450	899	727
EWWD530DZXSA1	1082	3624	1871	281	200	978	220	320	265	3170	139.7	139.7	450	899	-
EWWD570DZXE1	1082	3624	1871	281	200	978	220	320	265	3170	139.7	139.7	450	899	727
EWWD610DZXSA2	1082	3624	1871	281	200	978	220	320	265	3170	139.7	139.7	450	899	-
EWWD640DZXSA2	1147	3585	2027	305	252	1031	240	260	267	3170	168.3	168.3	490	913	-
EWWD670DZXE2	1082	3624	1871	281	200	978	220	320	265	3170	139.7	139.7	450	899	870
EWWD680DZXE2	1147	3585	2027	305	252	1031	240	260	267	3170	168.3	168.3	490	913	924
EWWD700DZXSA1	1147	3585	2027	305	252	1031	240	260	267	3170	168.3	168.3	490	913	-
EWWD740DZXE1	1147	3585	2027	305	252	1031	240	260	267	3170	168.3	168.3	490	913	806
EWWD880DZXSA2	1147	3585	2027	305	252	1031	240	260	267	3170	168.3	168.3	490	913	-
EWWD950DZXE2	1147	3585	2027	305	252	1031	240	260	267	3170	168.3	168.3	490	913	924
EWWD10DZXSA2	1257	3578	2200	340	240	1121	292	150	260	3170	219.1	168.3	670	973	-
EWWD11DZXE2	1257	3578	2200	340	240	1121	292	150	260	3170	219.1	168.3	670	973	1054
EWWD14DZXSA2	1257	3772	2200	343	284	1121	292	150	453	3170	219.1	219.1	670	973	-
EWWD15DZXE2	1257	3772	2200	343	284	1121	292	150	453	3170	219.1	219.1	670	973	1054

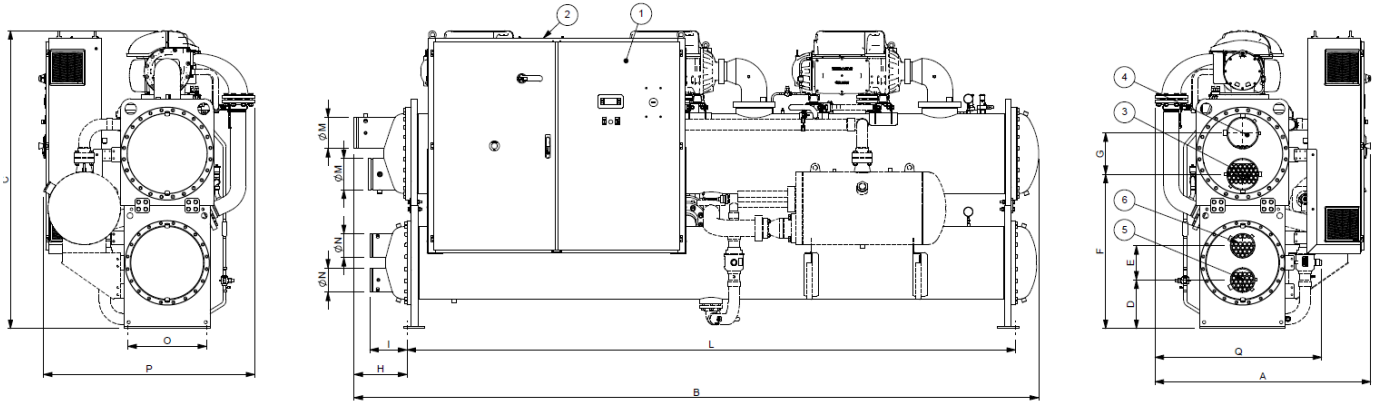

- LEGEND  
 1. ELECTRICAL PANEL  
 2. POWER SUPPLY CABLE ENTRY  
 3. EVAPORATOR WATER INLET  
 4. EVAPORATOR WATER OUTLET  
 5. CONDENSER WATER INLET  
 6. CONDENSER WATER OUTLET

	A	B	C	D	E	F	G	H	I	L	M	N	O	P	Q
EWWD10DZXE3	1510	4668	2081	340	240	1078	240	260	260	4260	168.3	168.3	550	1479	-
EWWD13DZXSA3	1510	4792	2083	340	240	1079	289	370	260	4260	219.1	168.3	550	-	1210
EWWD14DZXE3	1510	4792	2083	340	240	1079	289	370	260	4260	219.1	168.3	550	1479	-
EWWD15DZXSA3	1510	4768	2225	368	284	1146	292	150	350	4260	219.1	219.1	670	-	1124
EWWD17DZXE3	1510	4768	2225	368	284	1146	292	150	350	4260	219.1	219.1	670	1479	-
EWWD21DZXSA3	1510	4812	2290	360	300	1200	360	300	362	4260	219.1	219.1	670	-	1220
EWWD22DZXE3	1510	4812	2290	360	300	1200	360	300	362	4260	219.1	219.1	670	1479	-

## INSTALLATION NOTES

**Warning** Installation and maintenance of the unit must be performed only by qualified personnel who have knowledge with local codes and regulations, and experience with this type of equipment. Must be avoided the unit installation in places that could be considered dangerous for all the maintenance operations.

**Handling** Avoid bumping and/or jolting during loading/unloading unit from the truck and moving it. Secure the unit inside the truck to prevent it from moving and causing damages. Do not allow any part of the unit to fall during transportation or loading/unloading.

Use extreme caution when handling the unit to prevent damage to the control or the refrigerant piping. The unit must be lifted by attaching cables or chains at the lifting holes in each corner. For more information, please refer to the unit Installation Manual.

**Location** Unit is designed for indoor installation only. The unit must be mounted on a leveled base of concrete or steel. The unit must be installed on a robust and perfectly leveled foundation; it might be necessary to use weight distribution beams. Rubber mounts/pads as well as vibration isolators in all water piping connected to the chiller are recommended to avoid transmission of vibration and noise.

**Space requirements** Every side of the machine must be accessible for all post installation maintenance activities. The minimum space required is shown on the following drawing:

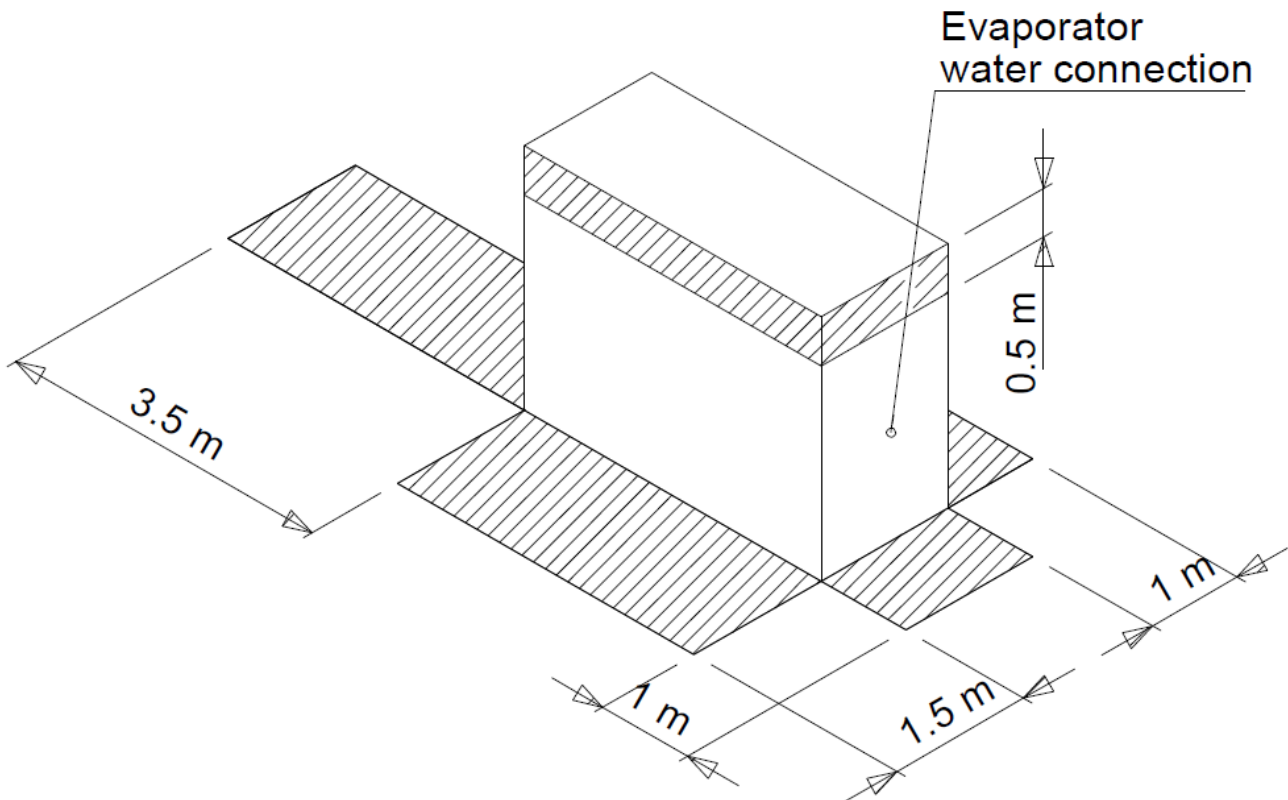

**Acoustic protection** When noise level must meet special requirements, it is necessary to pay the maximum attention to ensure the perfect insulation of the unit from the support base by applying appropriate anti-vibration devices on the unit, on the water pipes and on the electrical connections.

**Storage** The environment conditions have to be in the following limits:

- Maximum ambient temperature: 55°C
- Minimum ambient temperature: 5°C
- Maximum relative humidity: 95% not condensing

Storage below the minimum temperature may cause damage to components. Storage above the maximum temperature causes opening of safety valves. Storage in condensing atmosphere may damage electronic components.

## **TECHNICAL SPECIFICATIONS**

### **General**

The chiller will be designed and manufactured in accordance with the following European directives:

- Pressure Equipment Directive 2014/68/EU
- Machinery Directive 2006/42/EC
- Low Voltage Directive 2014/35/EU
- Electromagnetic Compatibility 2014/30/EU
- Electrical & Safety codes EN60204-1/EN61439-1/EN61439-2
- Manufacturing Quality Standards UNI EN ISO 9001:2004
- Environmental Management System UNI EN ISO 14001:2004
- Health & Safety Management System BS OHSAS 18001:2007

To avoid any losses, the unit will be tested at full load in the factory (at the nominal working conditions and water temperatures). The chiller will be delivered to the job site completely assembled and charged with refrigerant. The installation of the chiller must comply with the manufacturer's instructions for rigging and handling equipment. The unit will be able to start up and operate (as standard) at full load with:

- evaporator leaving fluid temperature between ... °C and ... °C
- condenser leaving fluid temperature from ... °C to ... °C

**Refrigerant** Only HFC 134a can be used.

**Performance** Chiller shall supply the following performances:

- Number of chillers: ..... units
- Cooling capacity for single chiller: ..... kW
- Power input for single chiller in cooling mode: ..... kW
- Flooded Shell & tube evaporator entering water temperature in cooling mode: ..... °C
- Flooded Shell & tube evaporator leaving water temperature in cooling mode: ..... °C
- Flooded Shell & tube evaporator water flow: ..... l/s
- Flooded Shell & tube condenser entering water temperature in cooling mode: ..... °C
- Flooded Shell & tube condenser leaving water temperature in cooling mode: ..... °C
- Flooded Shell & tube evaporator water flow: ..... l/s

Operating voltage range should be 400V ±10%, 3ph, 50Hz, voltage unbalance maximum 3%, without neutral conductor and shall only have one power connection point.

**Unit description** Chiller shall include as standard not less than: one refrigerant circuit, Oil free Centrifugal water cooled compressor (with integrated VFD), electronic expansion device (EEXV), flooded shell & tube heat exchangers, R134a refrigerant, control system and all components necessary for safe and stable unit operation. Chiller will be factory assembled, protected by an epoxy paint.

**Sound level and vibrations** Sound pressure level at 1 meter distance in free field, semispherical conditions, shall not exceed .....dB(A). The sound pressure levels must be rated in accordance to ISO 3744. Vibration on the base frame should not exceed 2 mm/s

**Dimensions** Unit dimensions shall not exceed following indications:

- Unit length ..... mm
- Unit width ..... mm
- Unit height ..... mm

## CHILLER COMPONENTS

**Compressors** The unit shall be equipped with:

- Magnetic bearing, oil free, semi-hermetic centrifugal compressors. The compressor drive train shall be capable of coming to a controlled, safe stop in the event of a power failure.
- The motor shall be of the semi-hermetic type, of sufficient size to efficiently fulfill compressor horsepower requirements. It shall be liquid refrigerant cooled with internal thermal sensing devices in the stator windings. The motor shall be compatible with variable frequency drive operation.
- The compressor shall be equipped with an integrated Variable Frequency Drive (VFD) to automatically regulate compressor speed in response to cooling load and the compressor pressure lift requirement. Movable inlet guide vanes and variable compressor speed, shall provide unloading. The chiller controls shall coordinate compressor speed and guide vane position to optimize chiller efficiency.
- Each compressor shall be equipped with a line reactor to help protect against incoming power surges and help reduce harmonic distortion.

**Evaporator** The units shall be equipped with a flooded shell-and-tube evaporator operating with refrigerant boiling in shell and water flowing inside the tubes. The tubes are enhanced for maximum heat transfer and rolled into steel tube sheet and sealed. The tubes are individually replaceable.

- The external shell shall be insulated with flexible, closed cell polyurethane insulation material (20-mm thick).
- Replaceable water tubes are fabricated from integral finned copper and mechanically bonded to steel tube sheets.
- The evaporator will have 1 circuit and standard configuration on water connection side is 2 passes.
- The water connections shall be VICTAULIC type connections as standard to ensure quick mechanical disconnection between the unit and the hydronic network.
- The evaporator will be manufactured in accordance to PED standard (2014/68/EU).
- The water side shall be designed for 10 bar of maximum operating pressure; vents and drain shall be provided.

**Condenser** The unit shall be equipped with flooded shell-and-tube condenser operating with refrigerant in shell and water in tubes.

Replaceable water tubes are fabricated from integral finned copper and mechanically bonded to steel tube sheets.

- The units will have one condenser on the refrigerant circuit.
- Standard configuration on water connection side is 2 passes.
- The water connections shall be VICTAULIC type connections as standard.
- The evaporator will be manufactured in accordance to PED standard (2014/68/EU).
- The water side shall be designed for 10 bar of maximum operating pressure; vents and drain shall be provided.

**Refrigerant circuit** The unit shall have one refrigerant circuit. Refrigerant circuit shall include as standard: electronic expansion device piloted by unit's microprocessor control, sight glass with moisture indicator and insulated suction line, Liquid line shut off valve, Liquid line temperature sensor, High pressure transducers, Low pressure transducers, Suction temperature sensor.

**Condensation control** The compressor automatically unloads when high condensing pressure is detected. This to prevent the shutdown of the refrigerant circuit (shutdown of the unit) due to a high-pressure fault.

**Low sound unit configuration (on request)** The chiller shall be provided with an acoustical compressor enclosure. This enclosure shall be realized with a light, corrosion resistant aluminum structure and metal panels. The compressor soundproof enclosure shall be internally fitted with flexible, multi-layer, high density materials.

**Electrical control panel** Power and control shall be located in the main panel that will be manufactured to ensure protection against all weather conditions.

- The electrical panel shall be IP54 and (with the doors opened) internally protected against possible accidental contact with electrical components (IP20).
- The main panel shall be fitted with a main switch interlocked door.
- The power section will include compressors protection devices and control circuit power supply.

**Controller** The controller will be installed as standard and it will be used to modify unit set-points and check control parameters. A display installed on the outside of the control panel's door will allow easy access to chiller operating status including water temperatures and refrigerant pressures and temperatures.

A sophisticated software with predictive logic will select the most energy efficient combination of compressor load and electronic expansion valve position keeping stable operating conditions and maximizing chiller efficiency and reliability.

In addition to normal operating functionalities, unit controller will take corrective actions in case the chiller operating outside recommended working conditions.

Unit controller shall be able to protect critical unit components thanks to the signals received by the various unit sensors (such as motor temperature sensors, refrigerant pressure/temperature sensors,.....etc..).

Controller shall guarantee following minimum functions:

- Optimized management of compressors stepless capacity control through inverter drive.
- Display of evaporator entering/leaving water temperatures.
- Display of condenser entering/leaving water temperatures.
- Display of refrigerant condensing/evaporating temperatures and pressures.
- Regulation of leaving evaporator water (cooling mode). Temp. tolerance  $\pm 0,1^{\circ}\text{C}$ .
- Display of compressor working hours and number of compressor starts.
- Re-start in case of power failure (automatic or manual depending on failure type).
- Soft load (optimized management of the compressor load during the start-up).
- Set point reset.
- Master/Slave operation (up to 4 chillers connected).

Controller shall guarantee following minimum alarms signaling:

- Phase loss.
- Evaporator water flow loss.
- Evaporator water freezing protection.
- External alarm.
- Low evaporator refrigerant pressure.
- High refrigerant pressure (transducer).
- High refrigerant discharge temperature.
- High motor temperature.

**High Level Communications Interface (on request)** The chiller shall be able to communicate to BMS (Building Management System) based on the most common protocols such as:

- ModbusRTU
- LonWorks
- BacNet BTP certified over IP and MS/TP (class 4) (Native)
- Ethernet TCP/IP.

**Master/Slave** The unit shall be able to operate in Master / Slave mode in order to be connected with other similar unit (up to 4). The master unit shall manage the slave units connected in series on the hydraulic plant with the aim of optimize the running hours of each compressor and to balance the load between the units.

**App Ready** The unit shall be able to operate with an App specifically designed to interface the user with the unit controller.

App shall be characterized by an easy-to-access data, and it allows an effective graphical representation of the main figures and displaying the unit operating parameters, accept set-point changes (multi-level password protected) and be capable of resetting faults and alarms. The following parameters shall be displayed on the home screen and also as trend curves on the trend screen:

- Entering and leaving chilled water temperatures
- Entering and leaving condenser water temperatures
- Evaporator saturated refrigerant pressure
- Condenser saturated refrigerant pressure
- Percent of 100% Rated Load Ampere (per compressor)

**Portable touch panel (on request)** The chiller shall be provided with a portable touch panel. Portable touch panel will be supplied fitted inside the unit control panel for easy removable configuration. It shall be provided together with the App already installed allowing a ready connection to the unit controller.



In all of us,  
a green heart



Daikin's unique position as a manufacturer of air conditioning equipment, compressors and refrigerants has led to its close involvement in environmental issues. For several years Daikin has had the intention to become a leader in the provision of products that have limited impact on the environment. This challenge demands the eco design and development of a wide range of products and an energy management system, resulting in energy conservation and a reduction of waste.



The present leaflet is drawn up by way of information only and does not constitute an offer binding upon Daikin Europe N.V. Daikin Europe N.V. has compiled the content of this leaflet to the best of its knowledge. No express or implied warranty is given for the completeness, accuracy, reliability or fitness for particular purpose of its content and the products and services presented therein. Specifications are subject to change without prior notice. Daikin Europe N.V. explicitly rejects any liability for any direct or indirect damage, in the broadest sense, arising from or related to the use and/or interpretation of this leaflet. All content is copyrighted by Daikin Europe N.V.

Daikin products are distributed by:

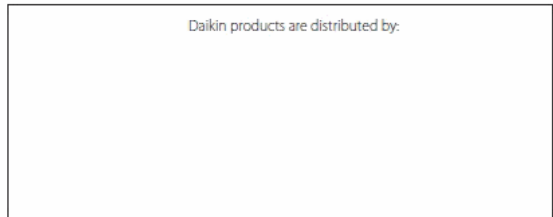

[www.eurovent-certification.com](http://www.eurovent-certification.com)  
[www.certiflash.com](http://www.certiflash.com)