

Air-cooled R-134a Heat Pump Inverter



EWYD BZ

SS (Standard Efficiency - Standard Noise) - Cooling Capacity from 250 to 580 kW
SL (Standard Efficiency - Low Noise) - Cooling Capacity from 250 to 570 kW

Performance according to EN14511.



www.eurovent-certification.com
www.certiflash.com



High part load efficiency McEnergy HPI “Extension” is the result of careful design, aimed to optimizing the energy efficiency of the chillers, with the objective of bringing down operating costs and improving installation profitability, effectiveness and economical management.

Per European Seasonal Energy Efficiency Ratio (ESEER), chillers operate at design conditions only three percent of the time. As a result better part load efficiencies are required at part load conditions in a heat pump application. McEnergy HPI “Extension” maximizes chiller efficiency by optimizing single screw compressor operation dramatically reducing the electric power consumption when the motor speed slows.

Seasonal quietness Very low noise levels in part load conditions are achieved by varying the fan speed, but especially thanks to the variation of compressor frequency, which ensure the minimum noise level at all the time.

Quick comfort conditions The ability to vary the output power in direct relation to the cooling requirements of the system, allow the possibility to achieve building comfort conditions much faster at start-up.

Low starting current No current spikes at start-up. The starting current is always lower than current absorbed in the maximum operating conditions (FLA).

Power factor always > 0.95 McEnergy HPI “Extension” can operate always > 0.95 power factor, which can allows building owners avoid power factor penalties and decreases electrical losses in cable and transformers.

Redundancy McEnergy HPI “Extension” has two or three truly independent refrigerant circuits in every size, in order to assure maximum safety for any maintenance, whether planned or not.

Infinite capacity control Cooling capacity control is infinitely variable by means of a single screw asymmetric compressor controlled by microprocessor system. Each unit has infinitely variable capacity control from 100% down to 12.5%. This modulation allows the compressor capacity to exactly match the building cooling load without any leaving evaporator water temperature fluctuation. This chilled water temperature fluctuation is avoided with a stepless control.

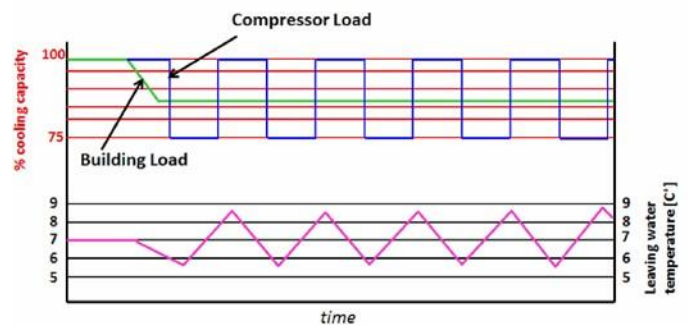

EWLT fluctuation with steps capacity control (4 steps)

With a compressor load step control in fact, the compressor capacity, at partial loads, will be too high or too low compared to the building cooling load. The result is an increase in chiller energy costs, particularly at the part-load conditions at which the chiller operates most of the time.

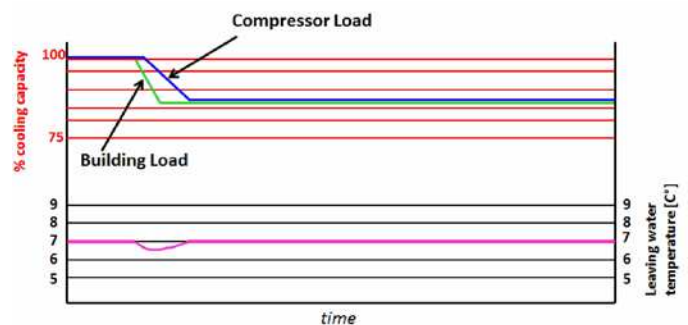

EWLT fluctuation with stepless capacity control

Units with stepless regulation offer benefits that the units with step regulation are unable to match. Only a chiller with stepless regulation, is able to follow the system cooling demand at any time and to deliver chilled water at set-point.

Code requirements – Safety and observant of laws/directives Units are designed and manufactured in accordance with applicable selections of the following:

Construction of pressure vessel	97/23/EC (PED)
Machinery Directive	2006/42/EC
Low Voltage	2006/95/EC
Electromagnetic Compatibility	2004/108/EC
Electrical & Safety codes	EN 60204-1 / EN 60335-2-40
Manufacturing Quality Stds	UNI – EN ISO 9001:2004

Certifications Units are CE marked, complying with European directives in force, concerning manufacturing and safety. On request units can be produced complying with laws in force in non European countries (ASME, GOST, etc.), and with other applications, such as naval (RINA, etc.).

Versions "McEnergy HPI "Extension" is available in standard efficiency version (SE):

SE: Standard Efficiency

13 sizes to cover a range from 254 up to 583 kW (Cooling Capacity) and from 270 up to 615 kW (Heating Capacity), with an EER up to 2.87, an ESEER up to 4.29 and a COP up to 3.04.

The EER (Energy Efficiency Ratio) is the ratio of the Cooling Capacity to the Power Input of the unit. The Power Input includes: the power input for operation of the compressor, the power input of all control and safety devices, the power input for fans.

The COP (Coefficient of Performance) is the ratio of the heating capacity to the power input of the unit.

The ESEER (European Seasonal Energy Efficiency Ratio) is a weighed formula enabling to take into account the variation of EER with the load rate and the variation of air inlet condenser temperature.

$$ESEER = A \times EER_{100\%} + B \times EER_{75\%} + C \times EER_{50\%} + D \times EER_{25\%}$$

	A	B	C	D
K	0.03 (3%)	0.33 (33%)	0.41 (41%)	0.23 (23%)
T	35°C	30°C	25°C	20°C

The Seasonal Coefficient Of Performances (SCOP) is the seasonal efficiency of a unit in active heating mode without supplementary electric heaters; calculated at the following conditions: Tivalent +2 °C, Tdesign -10 °C, Average ambient conditions, Ref. EN14825

Noise Configuration McEnergy HPI "Extension" is available in two different noise level configurations:

ST: Standard Noise

Condenser fan rotating at 920 rpm, rubber antivibration under compressor

LN: Low Noise

Condenser fan rotating at 715 rpm (920 rpm in heating mode), rubber antivibration under compressor, compressor sound enclosure.

Cabinet and structure The cabinet is made of galvanized steel sheet and painted to provide a high resistance to corrosion. Colour Ivory White (Munsell code 5Y7.5/1) (\pm RAL7044). The base frame has an eye-hook to lift the unit with ropes for an easy installation. The weight is uniformly distributed along the profiles of the base and this facilitates the arrangement of the unit.

Screw compressors with integrated oil separator The compressors are semi-hermetic, single-screw type with gate-rotor (made of carbon impregnated engineered composite material). Each compressor has one inverter managed by the unit microprocessor for infinitely modulating the capacity. An integrated high efficiency oil separator maximises the oil separation. Start is inverter type.

Refrigerant The compressors have been designed to operate with R-134a, ecological refrigerant with zero ODP (Ozone Depletion Potential) and very low GWP (Global Warming Potential), resulting in low TEWI (Total Equivalent Warming Impact).

Evaporator The units are equipped with a Direct Expansion shell&tube evaporator with copper tubes rolled into steel tubesheets. The evaporators are single-pass on both the refrigerant and water sides for pure counter-flow heat exchange and low refrigerant pressure drops. Both attributes contribute to the heat exchanger effectiveness and total unit's outstanding efficiency. The external shell is covered with a 10mm closed cell insulation material. Each evaporator has 2 or 3 circuits, one for each compressor and is manufactured in accordance to PED approval. The evaporator water outlet connections are provided with Victaulic Kit (as standard). The external shell is covered with a 10mm closed cell insulation material. Each evaporator has 2 or 3 circuits, one for each compressor and is manufactured in accordance to PED approval. The evaporator water outlet connections are provided with Victaulic Kit (as standard).

Condenser The condenser is manufactured with internally enhanced seamless copper tubes arranged in a staggered row pattern and mechanically expanded into lanced and rippled aluminum condenser fins with full fin collars. An integral sub-cooler circuit provides sub-cooling to effectively eliminate liquid flashing and increase cooling capacity without increasing the power input.

Condenser fans The condenser fans are propeller type with high efficiency design blades to maximize performances. The material of the blades is glass reinforced resin and each fan is protected by a guard. Fan motor is protected by circuit breaker installed inside the electrical panel as a standard. The motors are IP54.

Electronic expansion valve The unit is equipped with the most advanced electronic expansion valves to achieve precise control of refrigerant mass flow. As today's system requires improved energy efficiency, tighter temperature control, wider range of operating conditions and incorporate features like remote monitoring and diagnostics, the application of electronic expansion valves becomes mandatory.

Electronic expansion valves possess unique features: short opening and closing time, high resolution, positive shut-off function to eliminate use of additional solenoid valve, continuous modulation of mass flow without stress in the refrigerant circuit and corrosion resistance stainless steel body.

Electronic expansion valves are typically working with lower ΔP between high and low pressure side, than a thermostatic expansion valve. The electronic expansion valve allows the system to work with low condenser pressure (winter time) without any refrigerant flow problems and with a perfect chilled water leaving temperature control.

Refrigerant Circuit Each unit has 2 or 3 independent refrigerant circuits and each one includes:

- Compressor with integrated oil separator
- Air Cooled Condenser
- Electronic expansion valve
- Evaporator
- Discharge line shut off valve
- Liquid line shut off valve
- Suction line shut off valve
- Sight glass with moisture indicator
- Filter drier
- Charging valves
- High pressure switch
- High and low pressure transducers

Electrical control panel Power and control are located in two sections of the main panel that is manufactured to ensure protection against all weather conditions. The electrical panel is IP54 and (when opening the doors) internally protected with Plexiglas panel against possible accidental contact with electrical components (IP20). The main panel is fitted with a main switch interlocked door.

Power Section

The power section includes circuit breaker, compressors inverters, fans contactors, fans thermal overload relays, fans and control circuit transformer.

MicroTech II controller

MicroTech II C Plus controller is installed as standard; it can be used to modify unit set-points and check control parameters. A built-in display shows machine's operating status, programmable values, set-points, like temperatures and pressures of water, refrigerant and air. Device controls maximise the chiller energy efficiency and the reliability. A sophisticated software with predictive logic, select the most energy efficient combination of compressors, EEXV and condenser fans to keep stable operating conditions and maximise energy efficiency. The compressors are automatically rotated to ensure equal operating hours. MicroTech II C Plus protects critical components in response to external signals from its system sensors measuring: motor temperatures, refrigerant gas and oil pressures, correct phase sequence and evaporator.

Control section - main features

- Management of the compressor capacity, Inverter, slide and fans modulation.
- Chillers enabled to work in partial failure condition.
- Full routine operation at condition of:
 - high ambient temperature value,
 - high thermal load,
 - high evaporator entering water temperature (start-up).
- Display of evaporator entering/leaving water temperature.
- Display of condensing-evaporating temperature and pressure, suction and discharge superheat for each circuit.
- Leaving water cooled temperature regulation. Temperature tolerance = 0,1°C.
- Compressors and evaporator pumps hours counter.
- Display of Status Safety Devices.
- Start up numbers and compressors working hours equalization.
- Optimized management of compressors load.
- Fans management according to condensing pressure.
- Automatic re-start in case of power supply interruption (adjustable).
- Soft Load.
- Start at high evaporator water temperature.
- Return Reset.
- AOT Reset (optional).
- Set point Reset (optional).

Safety device / logic for each refrigerant circuit

The following devices / logics are available.

- High pressure (pressure switch).
- Low pressure (transducer).
- Condensation fan Magneto-thermal.
- High Discharge Temperature on the compressor.
- Phase Monitor.
- Low pressure ratio.
- High oil pressure drop.
- Low oil pressure.

System security

The following securities are available.

- Phase monitor.
- Freeze protection.

Regulation type

Proportional + integral + derivative regulation on the evaporator leaving water output probe.

Condensing Pressure

The condensation can be carried out according to temperature or pressure or pressure ratio. The fans can be managed according to a 0/10 V modulating signal.

Intelligent Compressor Start Mode

Control software includes an intelligent compressor start mode that unloads the first compressor to 75% during the start of the second one, in order to reduce inrush current.

MicroTech II C Plus terminal

MicroTech II C Plus built-in terminal has the following features.

- 4-lines by 20-character liquid crystal display back lighting.
- Key-pad consisting of 6 keys.
- Memory to protect the data.
- General faults alarm relays.
- Password access to modify the setting.
- Service report displaying all running hours and general conditions.
- Alarm history memory to allow an easy fault analysis.

Supervising systems (on request)

MicroTech II C Plus remote control

MicroTech II C Plus is able to communicate to BMS (Building Management System) based on the most common protocols as:

- CARELNative
- ModbusRTU
- LonWorks, now also based on the international 8040 Standard Chiller Profile and LonMark Technology
- BacNet BTP certifief over IP and MS/TP (class 4)
- Ethernet TCP/IP and SNM.

Standard Options (supplied on basic unit)

Inverter compressor starter - For low inrush current and reduced starting torque

Double setpoint - Dual leaving water temperature setpoints.

Fans circuit breaker with thermal overload relays - Safety devices against motor overloading and short circuit in addition to the normal protection envisaged by electrical windings.

Phase monitor - Device that monitors input voltage and stops the chiller in case of phase loss or wrong phase sequence.

Evaporator victaulic kit - Hydraulic joint with gasket for an easy and quick water connection.

10mm evaporator insulation - The external shell is covered with a 10mm closed cell insulation material.

Evaporator electric heater - Electric heater (controlled by a thermostat) to protect the evaporator from freezing down to -28°C ambient temperature, providing the power supply is on.

Electronic expansion valve

Ambient outside temperature sensor and setpoint reset

Discharge line shut-off valve - Installed on the discharge port of the compressor to facilitate maintenance operation.

Suction line shut-off valve - Installed on the suction port of the compressor to facilitate maintenance operation.

Low pressure side manometers

Hour run meter

General fault contactor

Main switch interlock door

Options (on request)

MECHANICAL

Partial heat recovery - Plate to plate heat exchangers for hot water production.

Brine version - Allows the unit to operate down to -8°C leaving liquid temperature (antifreeze required). Recommended below +4°C

20mm evaporator insulation - The external shell is covered with a 20mm closed cell insulation material.

Condenser coil guards

Cu-Cu condenser coil - To give better protection against corrosion by aggressive environments.

Cu-Cu-Sn condenser coil - To give better protection against corrosion in aggressive environments and by salty air.

Alucoat fins coil - Fins are protected by a special acrylic paint with a high resistance to corrosion.

High pressure side manometers

Low pressure side manometers

Water circulation pump (low or high lifting) – Not available for McEnergy HPI “Extension” SE 072.2÷167.3 LN. Hydronic kit consists of: single direct driven centrifugal pump, water filling system with pressure gauge, safety valve, drain valve. The motor pump is protected by a circuit breaker installed in control panel. The kit is assembled and wired to the control panel. The pipe and pump are protected from freezing with an additional electrical heater.

Two water circulation pumps (low or high lifting) – Not available for McEnergy HPI “Extension” SE 072.2÷167.3 LN. Hydronic kit consists of: twin direct driven centrifugal pumps, water filling system with pressure gauge, safety valve, drain valve. The motor pump is protected by a circuit breaker installed in control panel. The kit is assembled and wired to the control panel. The pipe and pumps are protected from freezing with an additional electrical heater.

Double pressure relief valve with diverter

Evaporator right water connections

ELECTRICAL / CONTROL

Under / Over voltage control - Electronic device that monitors and displays input voltage, and stops the chiller in case of phase loss, wrong phase sequence, or voltage exceeding minimum and maximum allowed values.

Energy meter - This device allows to measure the energy absorbed by the chiller during its life. It is installed inside the control box mounted on a DIN rail and show on a digital display: Line-to-Line Voltage, Phase and Average Current, Active and Reactive Power, Active Energy, Frequency.

Current limit - To limit maximum absorbed current of the unit whenever is required

Fan speed regulation – To control the fan speed revolution for smooth operating control of the unit. This option improves the sound level of the unit during low ambient temperature operation.

Fan Silent Mode - The microprocessor clock switches the fan at low speed according to the client setting (i.e. Night & Day), providing that the ambient temperature/condensing pressure is allowing the speed change. It allows a perfect condensing control down to -10°C.

Evaporator flow switch - Supplied separately to be wired and installed on the evaporator water piping (by the customer).

Setpoint reset, Demand limit and Alarm from external device - Setpoint Reset: The leaving water temperature set-point can be overwritten with an external 4-20mA, through the ambient temperature, or through the evaporator water temperature ΔT . Demand Limit: Chiller capacity can be limited through an external 4-20mA signal or via network. Alarm from external device: The unit controller is able to receive an external alarm signal. The user can decide whether this alarm signal will stop the unit or not.

Nordic kit

INSTALLATION

Rubber anti vibration mounts - Supplied separately, these are positioned under the base of the unit during installation. Ideal to reduce the vibrations when the unit is floor mounted.

Spring anti vibration mounts - Supplied separately, these are positioned under the base of the unit during installation. Ideal for dampening vibrations for installation on roofs and metallic structures.

External tank without cabinet (500 L)

External tank without cabinet (1000 L)

External tank with cabinet (500 L)

External tank with cabinet (1000 L)

OTHER

Container Kit

Witness test

Transport kit

Condenser coil protection panel - Wooden panels protecting the coils against possible damage are installed for shipment.

NOMENCLATURE

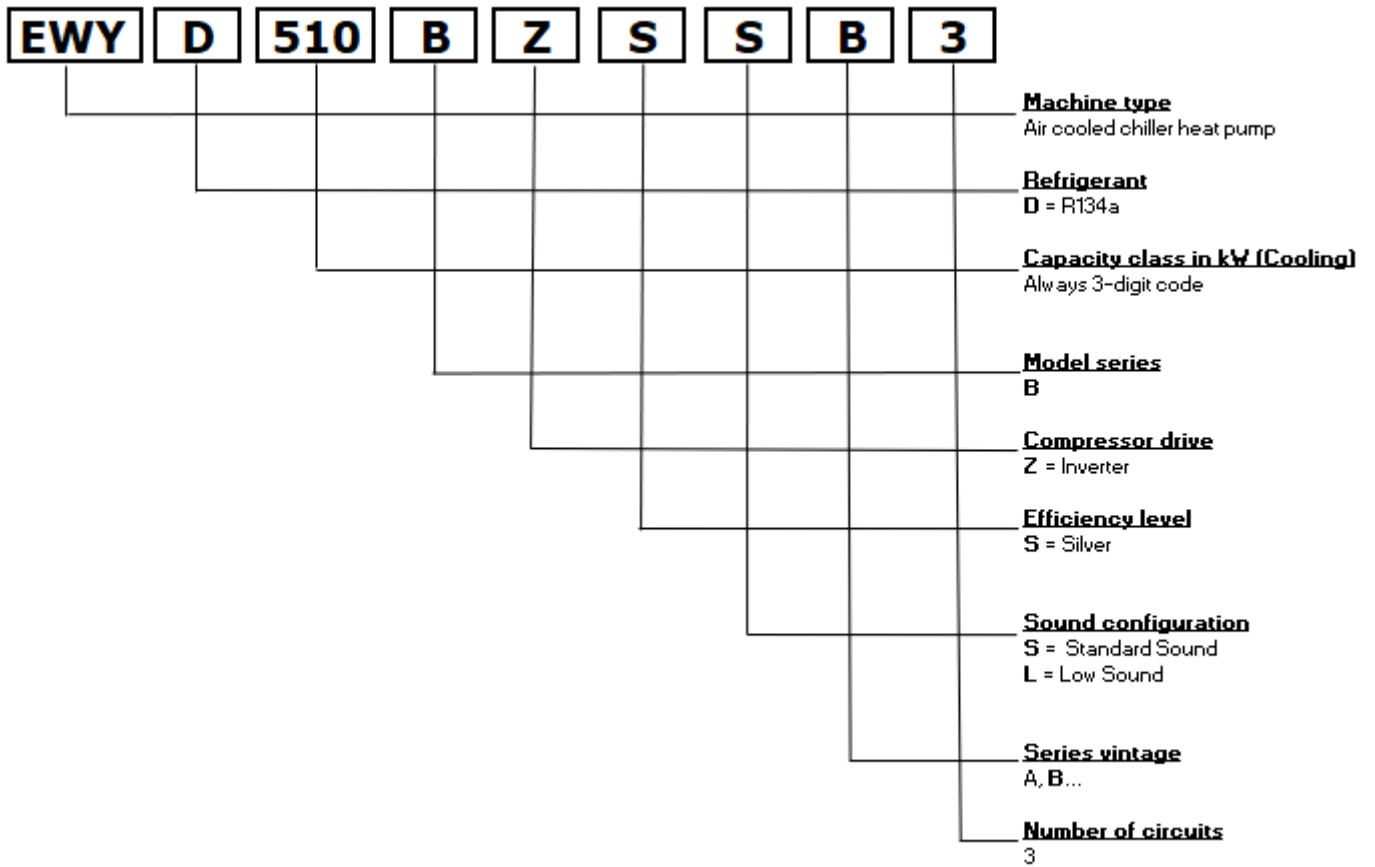

EWYD-BZ SS

EWYD~BZ- SS – standard unit							
MODEL	notes		250	270	290	320	340
Cooling Capacity	(1)	kW	253	272	291	323	337
Power Input	(1)	kW	91.3	101	110	117	125
EER	(1)	kW/kW	2.77	2.70	2.65	2.75	2.69
Minimum capacity	(2)	%	13.0	13.0	13.0	13.0	13.0
SEER	(3)	kW/kW	4.04	4.03	3.34	4.14	3.37
Evaporator type							
Evaporator type		-	Direct Expansion – Shell & Tubes				
Water flow rate	(1)	l/s	12.1	13	13.9	15.5	16.2
Evaporator pressure drop	(1) (4)	kPa	36.7	41.8	48.3	52.9	57.6
Evaporator water volume		lt	138	138	138	133	133
Sound Power							
Sound Power	(1) (5)	dB(A)	101	101	101	101	101
Sound Pressure @ 1 m	(1) (6)	dB(A)	82	82	82	82	82
Fan type							
Fan type		-	Direct Propeller				
Fan diameter		mm	800				
Fan rotational speed		RPM	900				
Fan motor / control		-	AC - VFD				
Number of fans		n	6	6	6	8	8
Air flow	(7)	l/s	31729	31422	31115	42306	42306
Refrigerant circuits							
Refrigerant circuits		n	2	2	2	2	2
Refrigerant type / GWP		-	R134a / GWP = 1430				
Refrigerant Charge	(8)	kg	86	88	86	92	93
Compressor type							
Compressor type		-	Single Screw				
Capacity control		-	Stepless – Variable Frequency Drive				
Oil charge		lt	26	26	26	26	26
Casing material		-	Galvanized Steel Sheet				
Color		-	Ivory White				
Unit length		mm	3547	3547	3547	4428	4428
Unit width		mm	2254	2254	2254	2254	2254
Unit height		mm	2335	2335	2335	2335	2335
Unit weight - shipping		kg	3410	3455	3500	3870	3870
Unit weight - operation		kg	3550	3595	3640	4010	4010
Water connection size		mm	139.7	139.7	139.7	139.7	139.7
Water connection type		-	Victaulic				
<p>(1) Standard Rating Conditions for Air to water chillers according to EN14511:2 Outdoor Heat exchanger inlet dry bulb temperature 35°; Indoor heat exchanger inlet water temperature 12°C, outlet water temperature 7°C. Fouling factor = 0</p> <p>(2) Minimum capacity for the unit operating at Standard Rating Conditions: Operating Ambient Temperature 35°C, Evaporator, water outlet 7°C</p> <p>(3) Seasonal Energy Efficiency Ratio as defined in EN14825, part load condition in cooling for Air to Water units, fan coil application, variable outlet, variable flow</p> <p>(4) Not including filter pressure drop. The installation of the filter is mandatory</p> <p>(5) Sound power level measured in accordance to ISO9614, referred to unit operating at Standard Rating Conditions for Air to water chillers according to EN14511:2 Outdoor Heat exchanger inlet dry bulb temperature 35°; Indoor heat exchanger inlet water temperature 12°C, outlet water temperature 7°C</p> <p>(6) Sound power level measured in accordance to ISO3744, referred to unit operating at Standard Rating Conditions for Air to water chillers according to EN14511:2 Outdoor Heat exchanger inlet dry bulb temperature 35°; Indoor heat exchanger inlet water temperature 12°C, outlet water temperature 7°C</p> <p>(7) Referred to unit with free discharge on condenser fans</p> <p>(8) Data subject to change. Refer to unit's name plate for actual value.</p> <p> Data certified by Eurovent certification scheme</p> <p>The above data are referred to the unit without additional optional.</p> <p>The above data are referred the unit installed in compliancy with installation prescription.</p> <p>All the data are subject to change without notice. For updated information on project base refer to Chiller Selection Software and unit's certified drawing</p>							

EWYD~BZ- SS – standard unit							
MODEL	notes		370	380	410	440	460
Cooling Capacity	(1)	kW	363.4	380.3	411.5	434.2	454.9
Power Input	(1)	kW	135	144	153	164	164
EER	(1)	kW/kW	2.69	2.64	2.68	2.64	2.78
Minimum capacity	(2)	%	13.0	13.0	13.0	13.0	9.0
SEER	(3)	kW/kW	3.38	3.98	4.09	4.1	4.39
Evaporator type		-	Direct Expansion – Shell & Tubes				
Water flow rate	(1)	l/s	17.4	18.2	19.7	20.8	21.8
Evaporator pressure drop	(1) (4)	kPa	52.6	57.4	46.2	51	61
Evaporator water volume		lt	128	128	128	128	240
Sound Power	(1) (5)	dB(A)	101	101	102	102	104
Sound Pressure @ 1 m	(1) (6)	dB(A)	82	82	83	83	84
Fan type		-	Direct Propeller				
Fan diameter		mm	800				
Fan rotational speed		RPM	900				
Fan motor / control		-	AC - VFD				
Number of fans		n	8	8	10	10	12
Air flow	(7)	l/s	42337	41487	52882	52882	63458
Refrigerant circuits		n	2	2	2	2	3
Refrigerant type / GWP		-	R134a / GWP = 1430				
Refrigerant Charge	(8)	kg	93	94	100	100	141
Compressor type		-	Single Screw				
Capacity control		-	Stepless – Variable Frequency Drive				
Oil charge		lt	26	26	26	26	39
Casing material		-	Galvanized Steel Sheet				
Color		-	Ivory White				
Unit length		mm	4428	4428	5329	5329	6659
Unit width		mm	2254	2254	2254	2254	2254
Unit height		mm	2335	2335	2335	2335	2280
Unit weight - shipping		kg	3940	4010	4390	4390	5015
Unit weight - operation		kg	4068	4138	4518	4518	5255
Water connection size		mm	139.7	139.7	139.7	139.7	219.1
Water connection type		-	Victaulic				
<p>(1) Standard Rating Conditions for Air to water chillers according to EN14511:2 Outdoor Heat exchanger inlet dry bulb temperature 35°; Indoor heat exchanger inlet water temperature 12°C, outlet water temperature 7°C. Fouling factor = 0</p> <p>(2) Minimum capacity for the unit operating at Standard Rating Conditions: Operating Ambient Temperature 35°C, Evaporator, water outlet 7°C</p> <p>(3) Seasonal Energy Efficiency Ratio as defined in EN14825, part load condition in cooling for Air to Water units, fan coil application, variable outlet, variable flow</p> <p>(4) Not including filter pressure drop. The installation of the filter is mandatory</p> <p>(5) Sound power level measured in accordance to ISO9614, referred to unit operating at Standard Rating Conditions for Air to water chillers according to EN14511:2 Outdoor Heat exchanger inlet dry bulb temperature 35°; Indoor heat exchanger inlet water temperature 12°C, outlet water temperature 7°C</p> <p>(6) Sound power level measured in accordance to ISO3744, referred to unit operating at Standard Rating Conditions for Air to water chillers according to EN14511:2 Outdoor Heat exchanger inlet dry bulb temperature 35°; Indoor heat exchanger inlet water temperature 12°C, outlet water temperature 7°C</p> <p>(7) Referred to unit with free discharge on condenser fans</p> <p>(8) Data subject to change. Refer to unit's name plate for actual value.</p> <p>■ Data certified by Eurovent certification scheme The above data are referred to the unit without additional optional. The above data are referred the unit installed in compliancy with installation prescription. All the data are subject to change without notice. For updated information on project base refer to Chiller Selection Software and unit's certified drawing</p>							

EWYD~BZ- SS B – standard unit					
MODEL	notes		510	530	570
Cooling Capacity	(1)	kW	515	532.6	569
Power Input	(1)	kW	183	190	217
EER	(1)	kW/kW	2.81	2.81	2.62
Minimum capacity	(2)	%	9.0	9.0	9.0
SEER	(3)	kW/kW	4.57	4.57	4.55
Evaporator type					
		-	Direct Expansion – Shell & Tubes		
Water flow rate	(1)	l/s	24.7	25.5	27.3
Evaporator pressure drop	(1) (4)	kPa	68.4	46.5	52.4
Evaporator water volume		lt	229	229	218
Sound Power					
	(1) (5)	dB(A)	104	104	104
Sound Pressure @ 1 m	(1) (6)	dB(A)	84	84	84
Fan type					
		-	Direct Propeller		
Fan diameter		mm	800		
Fan rotational speed		RPM	900		
Fan motor / control		-	AC - VFD		
Number of fans		n	12	12	12
Air flow	(7)	l/s	62640	61652	62231
Refrigerant circuits					
		n	3	3	3
Refrigerant type / GWP		-	R134a / GWP = 1430		
Refrigerant Charge	(8)	kg	141	141	147
Compressor type					
		-	Single Screw		
Capacity control		-	Stepless – Variable Frequency Drive		
Oil charge		lt	39	39	39
Casing material		-	Galvanized Steel Sheet		
Color		-	Ivory White		
Unit length		mm	6659	6659	6659
Unit width		mm	2254	2254	2254
Unit height		mm	2280	2280	2280
Unit weight - shipping		kg	5495	5735	5735
Unit weight - operation		kg	5724	5964	5953
Water connection size		mm	219.1	219.1	219.1
Water connection type		-	Victaulic		
<p>(1) Standard Rating Conditions for Air to water chillers according to EN14511:2 Outdoor Heat exchanger inlet dry bulb temperature 35°; Indoor heat exchanger inlet water temperature 12°C, outlet water temperature 7°C. Fouling factor = 0</p> <p>(2) Minimum capacity for the unit operating at Standard Rating Conditions: Operating Ambient Temperature 35°C, Evaporator, water outlet 7°C</p> <p>(3) Seasonal Energy Efficiency Ratio as defined in EN14825, part load condition in cooling for Air to Water units, fan coil application, variable outlet, variable flow</p> <p>(4) Not including filter pressure drop. The installation of the filter is mandatory</p> <p>(5) Sound power level measured in accordance to ISO9614, referred to unit operating at Standard Rating Conditions for Air to water chillers according to EN14511:2 Outdoor Heat exchanger inlet dry bulb temperature 35°; Indoor heat exchanger inlet water temperature 12°C, outlet water temperature 7°C</p> <p>(6) Sound power level measured in accordance to ISO3744, referred to unit operating at Standard Rating Conditions for Air to water chillers according to EN14511:2 Outdoor Heat exchanger inlet dry bulb temperature 35°; Indoor heat exchanger inlet water temperature 12°C, outlet water temperature 7°C</p> <p>(7) Referred to unit with free discharge on condenser fans</p> <p>(8) Data subject to change. Refer to unit's name plate for actual value.</p>					
<p>Data certified by Eurovent certification scheme</p> <p>The above data are referred to the unit without additional optional.</p> <p>The above data are referred the unit installed in compliancy with installation prescription.</p> <p>All the data are subject to change without notice. For updated information on project base refer to Chiller Selection Software and unit's certified drawing</p>					

EWYD-BZ SL

EWYD~BZ- SL – standard unit							
MODEL	notes		250	270	290	320	330
Cooling Capacity	(1)	kW	247.2	265.1	289.9	314.7	329.5
Power Input	(1)	kW	89.4	99.5	111	115	123
EER	(1)	kW/kW	2.76	2.67	2.62	2.75	2.68
Minimum capacity	(2)	%	13.0	13.0	13.0	13.0	13.0
SEER	(3)	kW/kW	3.98	3.99	3.91	4.09	3.95
Evaporator type							
		-	Direct Expansion – Shell & Tubes				
Water flow rate	(1)	l/s	11.8	12.7	13.9	15.1	15.8
Evaporator pressure drop	(1) (4)	kPa	35.1	39.9	45.9	50.8	55.2
Evaporator water volume		lt	138	138	138	133	133
Sound Power							
	(1) (5)	dB(A)	94	94	94	95	95
Sound Pressure @ 1 m							
	(1) (6)	dB(A)	76	76	76	76	76
Fan type							
		-	Direct Propeller				
Fan diameter							
		mm	800				
Fan rotational speed							
		RPM	700				
Fan motor / control							
		-	AC - VFD				
Number of fans							
		n	6	6	6	8	8
Air flow							
	(7)	l/s	24432	24264	24095	32576	32576
Refrigerant circuits							
		n	2	2	2	2	2
Refrigerant type / GWP							
		-	R134a / GWP = 1430				
Refrigerant Charge							
	(8)	kg	86	88	86	92	93
Compressor type							
		-	Single Screw				
Capacity control							
		-	Stepless – Variable Frequency Drive				
Oil charge							
		lt	26	26	26	26	26
Casing material							
		-	Galvanized Steel Sheet				
Color							
		-	Ivory White				
Unit length							
		mm	3547	3547	3547	4428	4428
Unit width							
		mm	2254	2254	2254	2254	2254
Unit height							
		mm	2335	2335	2335	2335	2335
Unit weight - shipping							
		kg	3750	3795	3840	4210	4210
Unit weight - operation							
		kg	3888	3933	3978	4343	4343
Water connection size							
		mm	139.7	139.7	139.7	139.7	139.7
Water connection type							
		-	Victaulic				
<p>(1) Standard Rating Conditions for Air to water chillers according to EN14511:2 Outdoor Heat exchanger inlet dry bulb temperature 35°; Indoor heat exchanger inlet water temperature 12°C, outlet water temperature 7°C. Fouling factor = 0</p> <p>(2) Minimum capacity for the unit operating at Standard Rating Conditions: Operating Ambient Temperature 35°C, Evaporator, water outlet 7°C</p> <p>(3) Seasonal Energy Efficiency Ratio as defined in EN14825, part load condition in cooling for Air to Water units, fan coil application, variable outlet, variable flow</p> <p>(4) Not including filter pressure drop. The installation of the filter is mandatory</p> <p>(5) Sound power level measured in accordance to ISO9614, referred to unit operating at Standard Rating Conditions for Air to water chillers according to EN14511:2 Outdoor Heat exchanger inlet dry bulb temperature 35°; Indoor heat exchanger inlet water temperature 12°C, outlet water temperature 7°C</p> <p>(6) Sound power level measured in accordance to ISO3744, referred to unit operating at Standard Rating Conditions for Air to water chillers according to EN14511:2 Outdoor Heat exchanger inlet dry bulb temperature 35°; Indoor heat exchanger inlet water temperature 12°C, outlet water temperature 7°C</p> <p>(7) Referred to unit with free discharge on condenser fans</p> <p>(8) Data subject to change. Refer to unit's name plate for actual value.</p>							
<p>Data certified by Eurovent certification scheme</p> <p>The above data are referred to the unit without additional optional.</p> <p>The above data are referred the unit installed in compliancy with installation prescription.</p> <p>All the data are subject to change without notice. For updated information on project base refer to Chiller Selection Software and unit's certified drawing</p>							

EWYD~BZ- SL – standard unit							
MODEL	notes		360	370	400	430	450
Cooling Capacity	(1)	kW	353.5	370.4	401.5	423.3	446
Power Input	(1)	kW	134	144	150	163	158
EER	(1)	kW/kW	2.64	2.58	2.67	2.60	2.82
Minimum capacity	(2)	%	13.0	13.0	13.0	13.0	9.0
SEER	(3)	kW/kW	3.93	3.92	4.27	4.27	4.28
Evaporator type		-	Direct Expansion – Shell & Tubes				
Water flow rate	(1)	l/s	16.9	17.7	19.2	20.3	21.4
Evaporator pressure drop	(1) (4)	kPa	50.2	54.7	44.4	48.9	58.8
Evaporator water volume		lt	128	128	128	128	240
Sound Power	(1) (5)	dB(A)	95	95	95	95	97
Sound Pressure @ 1 m	(1) (6)	dB(A)	76	76	76	76	77
Fan type		-	Direct Propeller				
Fan diameter		mm	800				
Fan rotational speed		RPM	700				
Fan motor / control		-	AC - VFD				
Number of fans		n	8	8	10	10	12
Air flow	(7)	l/s	32628	32127	40720	40720	48863
Refrigerant circuits		n	2	2	2	2	3
Refrigerant type / GWP		-	R134a / GWP = 1430				
Refrigerant Charge	(8)	kg	93	94	100	100	141
Compressor type		-	Single Screw				
Capacity control		-	Stepless – Variable Frequency Drive				
Oil charge		lt	26	26	26	26	39
Casing material		-	Galvanized Steel Sheet				
Color		-	Ivory White				
Unit length		mm	4428	4428	5329	5329	6659
Unit width		mm	2254	2254	2254	2254	2254
Unit height		mm	2335	2335	2335	2335	2280
Unit weight - shipping		kg	4280	4350	4730	4730	5525
Unit weight - operation		kg	4408	4478	4858	4858	5765
Water connection size		mm	139.7	139.7	139.7	139.7	219.1
Water connection type		-	Victaulic				
<p>(1) Standard Rating Conditions for Air to water chillers according to EN14511:2 Outdoor Heat exchanger inlet dry bulb temperature 35°; Indoor heat exchanger inlet water temperature 12°C, outlet water temperature 7°C. Fouling factor = 0</p> <p>(2) Minimum capacity for the unit operating at Standard Rating Conditions: Operating Ambient Temperature 35°C, Evaporator, water outlet 7°C</p> <p>(3) Seasonal Energy Efficiency Ratio as defined in EN14825, part load condition in cooling for Air to Water units, fan coil application, variable outlet, variable flow</p> <p>(4) Not including filter pressure drop. The installation of the filter is mandatory</p> <p>(5) Sound power level measured in accordance to ISO9614, referred to unit operating at Standard Rating Conditions for Air to water chillers according to EN14511:2 Outdoor Heat exchanger inlet dry bulb temperature 35°; Indoor heat exchanger inlet water temperature 12°C, outlet water temperature 7°C</p> <p>(6) Sound power level measured in accordance to ISO3744, referred to unit operating at Standard Rating Conditions for Air to water chillers according to EN14511:2 Outdoor Heat exchanger inlet dry bulb temperature 35°; Indoor heat exchanger inlet water temperature 12°C, outlet water temperature 7°C</p> <p>(7) Referred to unit with free discharge on condenser fans</p> <p>(8) Data subject to change. Refer to unit's name plate for actual value.</p> <p>■ Data certified by Eurovent certification scheme The above data are referred to the unit without additional optional. The above data are referred the unit installed in compliancy with installation prescription. All the data are subject to change without notice. For updated information on project base refer to Chiller Selection Software and unit's certified drawing</p>							

EWYD~BZ- SL B – standard unit					
MODEL	notes		510	530	570
Cooling Capacity	(1)	kW	502.8	519.2	569.0
Power Input	(1)	kW	178	186	217
EER	(1)	kW/kW	2.82	2.80	2.62
Minimum capacity	(2)	%	9.0	9.0	9.0
SEER	(3)	kW/kW	4.56	4.60	4.55
Evaporator type					
		-	Direct Expansion – Shell & Tubes		
Water flow rate	(1)	l/s	24.1	24.9	27.3
Evaporator pressure drop	(1) (4)	kPa	65.5	44.4	52.4
Evaporator water volume		lt	229	229	218
Sound Power					
	(1) (5)	dB(A)	97	97	97
Sound Pressure @ 1 m					
	(1) (6)	dB(A)	77	77	77
Fan type					
		-	Direct Propeller		
Fan diameter		mm	800		
Fan rotational speed		RPM	700		
Fan motor / control					
		-	AC - VFD		
Number of fans		n	12	12	12
Air flow	(7)	l/s	48415	47732	48191
Refrigerant circuits					
		n	3	3	3
Refrigerant type / GWP					
		-	R134a / GWP = 1430		
Refrigerant Charge	(8)	kg	141	141	147
Compressor type					
		-	Single Screw		
Capacity control					
		-	Stepless – Variable Frequency Drive		
Oil charge		lt	39	39	39
Casing material					
		-	Galvanized Steel Sheet		
Color					
		-	Ivory White		
Unit length		mm	6659	6659	6659
Unit width		mm	2254	2254	2254
Unit height		mm	2280	2280	2280
Unit weight - shipping		kg	6005	6245	6245
Unit weight - operation		kg	6234	6474	6463
Water connection size		mm	219.1	219.1	219.1
Water connection type					
		-	Victaulic		
<p>(1) Standard Rating Conditions for Air to water chillers according to EN14511:2 Outdoor Heat exchanger inlet dry bulb temperature 35°; Indoor heat exchanger inlet water temperature 12°C, outlet water temperature 7°C. Fouling factor = 0</p> <p>(2) Minimum capacity for the unit operating at Standard Rating Conditions: Operating Ambient Temperature 35°C, Evaporator, water outlet 7°C</p> <p>(3) Seasonal Energy Efficiency Ratio as defined in EN14825, part load condition in cooling for Air to Water units, fan coil application, variable outlet, variable flow</p> <p>(4) Not including filter pressure drop. The installation of the filter is mandatory</p> <p>(5) Sound power level measured in accordance to ISO9614, referred to unit operating at Standard Rating Conditions for Air to water chillers according to EN14511:2 Outdoor Heat exchanger inlet dry bulb temperature 35°; Indoor heat exchanger inlet water temperature 12°C, outlet water temperature 7°C</p> <p>(6) Sound power level measured in accordance to ISO3744, referred to unit operating at Standard Rating Conditions for Air to water chillers according to EN14511:2 Outdoor Heat exchanger inlet dry bulb temperature 35°; Indoor heat exchanger inlet water temperature 12°C, outlet water temperature 7°C</p> <p>(7) Referred to unit with free discharge on condenser fans</p> <p>(8) Data subject to change. Refer to unit's name plate for actual value.</p> <p> Data certified by Eurovent certification scheme</p> <p>The above data are referred to the unit without additional optional.</p> <p>The above data are referred the unit installed in compliancy with installation prescription.</p> <p>All the data are subject to change without notice. For updated information on project base refer to Chiller Selection Software and unit's certified drawing</p>					

EWYD-BZ SS

EWYD~BZ- SS – standard unit							
MODEL	notes		250	270	290	320	340
Heating Capacity	(1)	kW	271	298.3	325.6	334.5	350.7
Power Input	(1)	kW	91.6	100	108	118	127
COP	(1)	kW/kW	2.96	2.97	3.02	2.82	2.77
SCOP	(2)		3.21	3.21	3.20	3.20	3.21
<p>(1) All the performances (Heating capacity, unit power input in heating and COP) are based on the following conditions: 40,0/45,0°C; ambient 7,0°C, unit at full load operation; operating fluid: Water; fouling factor = 0. EN14511:2018</p> <p>(2) For indication only. According to Commission Regulation (EU) 2016/2281 these units are declared as Air Cooled Chillers</p>							

EWYD~BZ- SS – standard unit							
MODEL	notes		370	380	410	440	460
Heating Capacity	(1)	kW	380.7	412.1	444.8	465.1	477.4
Power Input	(1)	kW	134	143	157	167	166
COP	(1)	kW/kW	2.85	2.88	2.84	2.79	2.87
SCOP	(2)		3.21	3.21	3.21	3.20	3.20
<p>(1) All the performances (Heating capacity, unit power input in heating and COP) are based on the following conditions: 40,0/45,0°C; ambient 7,0°C, unit at full load operation; operating fluid: Water; fouling factor = 0. EN14511:2018</p> <p>(2) For indication only. According to Commission Regulation (EU) 2016/2281 these units are declared as Air Cooled Chillers</p>							

EWYD~BZ- SS B – standard unit					
MODEL	notes		510	530	570
Heating Capacity	(1)	kW	532.9	560.6	618.3
Power Input	(1)	kW	177	185	208
COP	(1)	kW/kW	3.00	3.03	2.97
SCOP	(2)		3.41	3.45	3.41
<p>(1) All the performances (Heating capacity, unit power input in heating and COP) are based on the following conditions: 40,0/45,0°C; ambient 7,0°C, unit at full load operation; operating fluid: Water; fouling factor = 0. EN14511:2018</p> <p>(2) For indication only. According to Commission Regulation (EU) 2016/2281 these units are declared as Air Cooled Chillers</p>					

EWYD-BZ SL

EWYD~BZ- SL – standard unit							
MODEL	notes		250	270	290	320	330
Heating Capacity	(1)	kW	271	298.3	325.6	334.5	350.7
Power Input	(1)	kW	91.6	100	108	118	127
COP	(1)	kW/kW	2.96	2.97	3.02	2.83	2.77
SCOP	(2)		3.21	3.21	3.20	3.20	3.21
<p>(1) All the performances (Heating capacity, unit power input in heating and COP) are based on the following conditions: 40,0/45,0°C; ambient 7,0°C, unit at full load operation; operating fluid: Water; fouling factor = 0. EN14511:2018</p> <p>(2) For indication only. According to Commission Regulation (EU) 2016/2281 these units are declared as Air Cooled Chillers</p>							

EWYD~BZ- SL – standard unit							
MODEL	notes		360	370	400	430	450
Heating Capacity	(1)	kW	380.7	412.1	444.8	465.1	477.4
Power Input	(1)	kW	133	143	157	167	166
COP	(1)	kW/kW	2.85	2.89	2.84	2.79	2.87
SCOP	(2)		3.21	3.21	3.21	3.20	3.20
<p>(1) All the performances (Heating capacity, unit power input in heating and COP) are based on the following conditions: 40,0/45,0°C; ambient 7,0°C, unit at full load operation; operating fluid: Water; fouling factor = 0. EN14511:2018</p> <p>(2) For indication only. According to Commission Regulation (EU) 2016/2281 these units are declared as Air Cooled Chillers</p>							

EWYD~BZ- SL B – standard unit					
MODEL	notes		510	530	570
Heating Capacity	(1)	kW	532.9	560.6	618.3
Power Input	(1)	kW	177	185	208
COP	(1)	kW/kW	3.00	3.03	2.97
SCOP	(2)		3.41	3.45	3.41
<p>(1) All the performances (Heating capacity, unit power input in heating and COP) are based on the following conditions: 40,0/45,0°C; ambient 7,0°C, unit at full load operation; operating fluid: Water; fouling factor = 0. EN14511:2018</p> <p>(2) For indication only. According to Commission Regulation (EU) 2016/2281 these units are declared as Air Cooled Chillers</p>					

EWYD-BZ SS

EWYD~BZ- SS – standard unit						
MODEL		250	270	290	320	340
Phases	n	3				
Frequency	Hz	50				
Voltage	V	400				
Voltage Tolerances min/max	%	-10/ +10				
Nominal Running Current	A	150	163	178	192	205
Max. running current	A	244	244	244	292	332
Max. current for wire sizing	A	244	244	244	292	332
Fan starting method	-	VFD				
Max running current per fan	A	4				
Total fans running current cooling	A	24	24	24	32	32
Compressor starting method		Variable Frequency Drive				
Max. running current Compressor #1	A	110	110	110	110	150
Max. running current Compressor #2	A	110	110	110	150	150
Max. running current Compressor #3	A	/	/	/	/	/
Main switch size	A	400	400	400	400	400
Cable per phase	-	3x185 + PE 95 mm ²	3x185 + PE 95 mm ²	3x185 + PE 95 mm ²	3x240 + PE 120 mm ²	3x240 + PE 120 mm ²
Short circuit current I _{cw} 1 sec.	kA	15	15	15	15	15

Fluid: Water

Allowed voltage tolerance $\pm 10\%$. Voltage unbalance between phases must be within $\pm 3\%$.

Maximum starting current: starting current of biggest compressor + current of the other compressors at maximum load + fans current at maximum load. In case of inverter driven units, no inrush current at start up is experienced.

Nominal current in cooling mode is referred to the following conditions: evaporator 12/7°C; ambient 35°C; compressors + fans current.

Maximum running current is based on max compressor absorbed current in its envelope and max fans absorbed current

Maximum unit current for wires sizing is based on minimum allowed voltage

EWYD~BZ- SS – standard unit						
MODEL		370	380	410	440	460
Phases	n	3				
Frequency	Hz	50				
Voltage	V	400				
Voltage Tolerances min/max	%	-10/ +10				
Nominal Running Current	A	220	232	249	265	267
Max. running current	A	332	332	371	402	378
Max. current for wire sizing	A	332	332	371	402	378
Fan starting method	-	VFD				
Max running current per fan	A	4				
Total fans running current cooling	A	32	32	40	40	48
Compressor starting method		Variable Frequency Drive				
Max. running current Compressor #1	A	150	150	150	181	110
Max. running current Compressor #2	A	150	150	181	181	110
Max. running current Compressor #3	A	/	/	/	/	110
Main switch size	A	400	400	630	630	630
Cable per phase	-	3x240 + PE 120 mm ²	3x240 + PE 120 mm ²	6x150 + PE 150 mm ²	6x150 + PE 150 mm ²	6x150 + PE 150 mm ²
Short circuit current I _{cw} 1 sec.	kA	15	15	20	20	20

Fluid: Water

Allowed voltage tolerance $\pm 10\%$. Voltage unbalance between phases must be within $\pm 3\%$.

Maximum starting current: starting current of biggest compressor + current of the other compressors at maximum load + fans current at maximum load. In case of inverter driven units, no inrush current at start up is experienced.

Nominal current in cooling mode is referred to the following conditions: evaporator 12/7°C; ambient 35°C; compressors + fans current.

Maximum running current is based on max compressor absorbed current in its envelope and max fans absorbed current

Maximum unit current for wires sizing is based on minimum allowed voltage

EWYD~BZ- SS B – standard unit				
MODEL		510	530	570
Phases	n	3		
Frequency	Hz	50		
Voltage	V	400		
Voltage Tolerances min/max	%	-10/ +10		
Nominal Running Current	A	298	310	349
Max. running current	A	458	498	498
Max. current for wire sizing	A	458	498	498
Fan starting method	-	VFD		
Max running current per fan	A	4		
Total fans running current cooling	A	48	48	48
Compressor starting method		Variable Frequency Drive		
Max. running current Compressor #1	A	150	150	150
Max. running current Compressor #2	A	150	150	150
Max. running current Compressor #3	A	110	150	150
Main switch size	A	630	630	630
Cable per phase	-	6x185 + PE 185 mm ²	6x185 + PE 185 mm ²	6x185 + PE 185 mm ²
Short circuit current I _{cw} 1 sec.	kA	20	20	20

Fluid: Water

Allowed voltage tolerance ± 10%. Voltage unbalance between phases must be within ± 3%.

Maximum starting current: starting current of biggest compressor + current of the other compressors at maximum load + fans current at maximum load. In case of inverter driven units, no inrush current at start up is experienced.

Nominal current in cooling mode is referred to the following conditions: evaporator 12/7°C; ambient 35°C; compressors + fans current.

Maximum running current is based on max compressor absorbed current in its envelope and max fans absorbed current

Maximum unit current for wires sizing is based on minimum allowed voltage

EWYD-BZ SL

EWYD~BZ- SL – standard unit						
MODEL		250	270	290	320	330
Phases	n	3				
Frequency	Hz	50				
Voltage	V	400				
Voltage Tolerances min/max	%	-10/ +10				
Nominal Running Current						
	A	147	161	177	187	201
Max. running current						
	A	244	244	244	292	332
Max. current for wire sizing						
	A	244	244	244	292	332
Fan starting method						
	-	VFD				
Max running current per fan						
	A	2.6				
Total fans running current cooling						
	A	15.6	15.6	15.6	20.8	20.8
Compressor starting method						
		Variable Frequency Drive				
Max. running current Compressor #1						
	A	110	110	110	110	150
Max. running current Compressor #2						
	A	110	110	110	150	150
Max. running current Compressor #3						
	A	/	/	/	/	/
Main switch size						
	A	400	400	400	400	400
Cable per phase						
	-	3x185 + PE 95 mm ²	3x185 + PE 95 mm ²	3x185 + PE 95 mm ²	3x240 + PE 120 mm ²	3x240 + PE 120 mm ²
Short circuit current I _{cw} 1 sec.						
	kA	15	15	15	15	15

Fluid: Water

Allowed voltage tolerance $\pm 10\%$. Voltage unbalance between phases must be within $\pm 3\%$.

Maximum starting current: starting current of biggest compressor + current of the other compressors at maximum load + fans current at maximum load. In case of inverter driven units, no inrush current at start up is experienced.

Nominal current in cooling mode is referred to the following conditions: evaporator 12/7°C; ambient 35°C; compressors + fans current.

Maximum running current is based on max compressor absorbed current in its envelope and max fans absorbed current

Maximum unit current for wires sizing is based on minimum allowed voltage

EWYD~BZ- SL – standard unit						
MODEL		360	370	400	430	450
Phases	n	3				
Frequency	Hz	50				
Voltage	V	400				
Voltage Tolerances min/max	%	-10/ +10				
Nominal Running Current	A	217	230	244	261	258
Max. running current	A	332	332	371	374	333
Max. current for wire sizing	A	332	332	371	374	333
Fan starting method	-	VFD				
Max running current per fan	A	2.6				
Total fans running current cooling	A	20.8	20.8	26	26	31.2
Compressor starting method		Variable Frequency Drive				
Max. running current Compressor #1	A	150	150	150	181	110
Max. running current Compressor #2	A	150	150	181	181	110
Max. running current Compressor #3	A	/	/	/	/	110
Main switch size	A	400	400	630	630	630
Cable per phase	-	3x240 + PE 120 mm ²	3x240 + PE 120 mm ²	6x150 + PE 150 mm ²	6x150 + PE 150 mm ²	6x150 + PE 150 mm ²
Short circuit current I _{cw} 1 sec.	kA	15	15	20	20	20

Fluid: Water

Allowed voltage tolerance $\pm 10\%$. Voltage unbalance between phases must be within $\pm 3\%$.

Maximum starting current: starting current of biggest compressor + current of the other compressors at maximum load + fans current at maximum load. In case of inverter driven units, no inrush current at start up is experienced.

Nominal current in cooling mode is referred to the following conditions: evaporator 12/7°C; ambient 35°C; compressors + fans current.

Maximum running current is based on max compressor absorbed current in its envelope and max fans absorbed current

Maximum unit current for wires sizing is based on minimum allowed voltage

EWYD~BZ- SL B – standard unit				
MODEL		510	530	570
Phases	n	3		
Frequency	Hz	50		
Voltage	V	400		
Voltage Tolerances min/max	%	-10/ +10		
Nominal Running Current	A	291	305	349
Max. running current	A	458	498	498
Max. current for wire sizing	A	458	498	498
Fan starting method	-	VFD		
Max running current per fan	A	2.6		
Total fans running current cooling	A	31.2	31.2	31.2
Compressor starting method		Variable Frequency Drive		
Max. running current Compressor #1	A	150	150	150
Max. running current Compressor #2	A	150	150	150
Max. running current Compressor #3	A	110	150	150
Main switch size	A	630	630	630
Cable per phase	-	6x185 + PE 185 mm ²	6x185 + PE 185 mm ²	6x185 + PE 185 mm ²
Short circuit current I _{cw} 1 sec.	kA	20	20	20

Fluid: Water

Allowed voltage tolerance $\pm 10\%$. Voltage unbalance between phases must be within $\pm 3\%$.

Maximum starting current: starting current of biggest compressor + current of the other compressors at maximum load + fans current at maximum load. In case of inverter driven units, no inrush current at start up is experienced.

Nominal current in cooling mode is referred to the following conditions: evaporator 12/7°C; ambient 35°C; compressors + fans current.

Maximum running current is based on max compressor absorbed current in its envelope and max fans absorbed current

Maximum unit current for wires sizing is based on minimum allowed voltage

EWYD-BZ SS

EWYD~BZ- SS – standard unit										
Model	Sound pressure level @ 1 m from the unit (rif. 2×10^{-5} Pa)								Sound pressure Lp @ 1 m	Sound power Lw
	63 Hz	125 Hz	250 Hz	500 Hz	1000 Hz	2000 Hz	4000 Hz	8000 Hz		
	dB								dB(A)	dB(A)
250	77,0	75,6	75,8	74,9	81,1	69,3	60,7	51,9	82	101
270	77,0	75,6	75,8	74,9	81,1	69,3	60,7	51,9	82	101
290	77,0	75,6	75,8	74,9	81,1	69,3	60,7	51,9	82	101
320	77,2	75,8	76,0	75,1	81,3	69,5	60,9	52,1	82	101
340	77,2	75,8	76,0	75,1	81,3	69,5	60,9	52,1	82	101
370	77,2	75,8	76,0	75,1	81,3	69,5	60,9	52,1	82	101
380	77,2	75,8	76,0	75,1	81,3	69,5	60,9	52,1	82	101
410	77,4	76,0	76,2	75,3	81,5	69,7	61,1	52,3	83	102
440	77,4	76,0	76,2	75,3	81,5	69,7	61,1	52,3	83	102
460	78,6	77,2	77,4	76,5	82,7	70,9	62,3	53,5	84	104
510	78,6	77,2	77,4	76,5	82,7	70,9	62,3	53,5	84	104
530	78,6	77,2	77,4	76,5	82,7	70,9	62,3	53,5	84	104
570	78,6	77,2	77,4	76,5	82,7	70,9	62,3	53,5	84	104

EWYD-BZ SL

EWYD~BZ- SL – standard unit										
Model	Sound pressure level @ 1 m from the unit (rif. 2×10^{-5} Pa)								Sound pressure Lp @ 1 m	Sound power Lw
	63 Hz	125 Hz	250 Hz	500 Hz	1000 Hz	2000 Hz	4000 Hz	8000 Hz		
	dB								dB(A)	dB(A)
250	76,1	72,4	70,9	69,6	74,2	63,9	55,5	46,3	76	94
270	76,1	72,4	70,9	69,6	74,2	63,9	55,5	46,3	76	94
290	76,1	72,4	70,9	69,6	74,2	63,9	55,5	46,3	76	94
320	76,3	72,6	71,1	69,8	74,4	64,1	55,7	46,5	76	95
330	76,3	72,6	71,1	69,8	74,4	64,1	55,7	46,5	76	95
360	76,3	72,6	71,1	69,8	74,4	64,1	55,7	46,5	76	95
370	76,3	72,6	71,1	69,8	74,4	64,1	55,7	46,5	76	95
400	76,5	72,8	71,3	70,0	74,6	64,3	55,9	46,7	76	95
430	76,5	72,8	71,3	70,0	74,6	64,3	55,9	46,7	76	95
450	77,7	74,0	72,5	71,2	75,8	65,5	57,1	47,9	77	97
510	77,7	74,0	72,5	71,2	75,8	65,5	57,1	47,9	77	97
530	77,7	74,0	72,5	71,2	75,8	65,5	57,1	47,9	77	97
570	77,7	74,0	72,5	71,2	75,8	65,5	57,1	47,9	77	97

EWYD-BZ SS

EWYD~BZ- SS – standard unit							
Model	Sound pressure at different distances [dB(A)]						
	@ 1 m	@ 5 m	@ 10 m	@ 15 m	@ 20 m	@ 25 m	@ 50 m
250	82,1	74,2	69,4	66,3	64,1	62,3	56,5
270	82,1	74,2	69,4	66,3	64,1	62,3	56,5
290	82,1	74,2	69,4	66,3	64,1	62,3	56,5
320	82,3	74,7	69,9	66,9	64,6	62,9	57,1
340	82,3	74,7	69,9	66,9	64,6	62,9	57,1
370	82,3	74,7	69,9	66,9	64,6	62,9	57,1
380	82,3	74,7	69,9	66,9	64,6	62,9	57,1
410	82,5	75,1	70,5	67,4	65,2	63,4	57,7
440	82,5	75,1	70,5	67,4	65,2	63,4	57,7
460	83,7	76,6	72,0	69,0	66,8	65,1	59,4
510	83,7	76,6	72,0	69,0	66,8	65,1	59,4
530	83,7	76,6	72,0	69,0	66,8	65,1	59,4
570	83,7	76,6	72,0	69,0	66,8	65,1	59,4

EWYD-BZ SL

EWYD~BZ- SL – standard unit							
Model	Sound pressure at different distances [dB(A)]						
	@ 1 m	@ 5 m	@ 10 m	@ 15 m	@ 20 m	@ 25 m	@ 50 m
250	75,6	67,7	62,9	59,8	57,6	55,8	50,0
270	75,6	67,7	62,9	59,8	57,6	55,8	50,0
290	75,6	67,7	62,9	59,8	57,6	55,8	50,0
320	75,8	68,2	63,4	60,4	58,1	56,4	50,6
330	75,8	68,2	63,4	60,4	58,1	56,4	50,6
360	75,8	68,2	63,4	60,4	58,1	56,4	50,6
370	75,8	68,2	63,4	60,4	58,1	56,4	50,6
400	76,0	68,6	64,0	60,9	58,7	56,9	51,2
430	76,0	68,6	64,0	60,9	58,7	56,9	51,2
450	77,2	70,1	65,5	62,5	60,3	58,6	52,9
510	77,2	70,1	65,5	62,5	60,3	58,6	52,9
530	77,2	70,1	65,5	62,5	60,3	58,6	52,9
570	77,2	70,1	65,5	62,5	60,3	58,6	52,9

Fluid: Water

Note: The values are according to ISO 3744 and are referred to: evaporator 12/7° C, air ambient 35°C, full load operation

Operating Limits

Cooling Mode

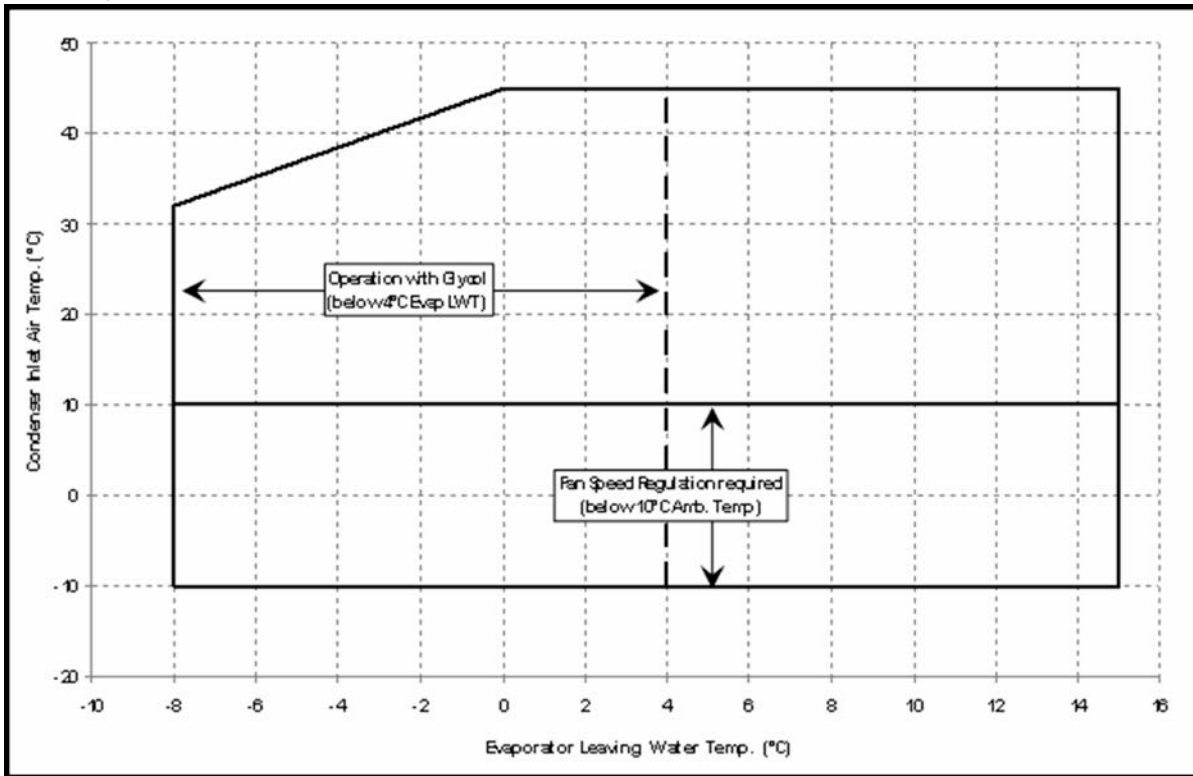

Heating Mode

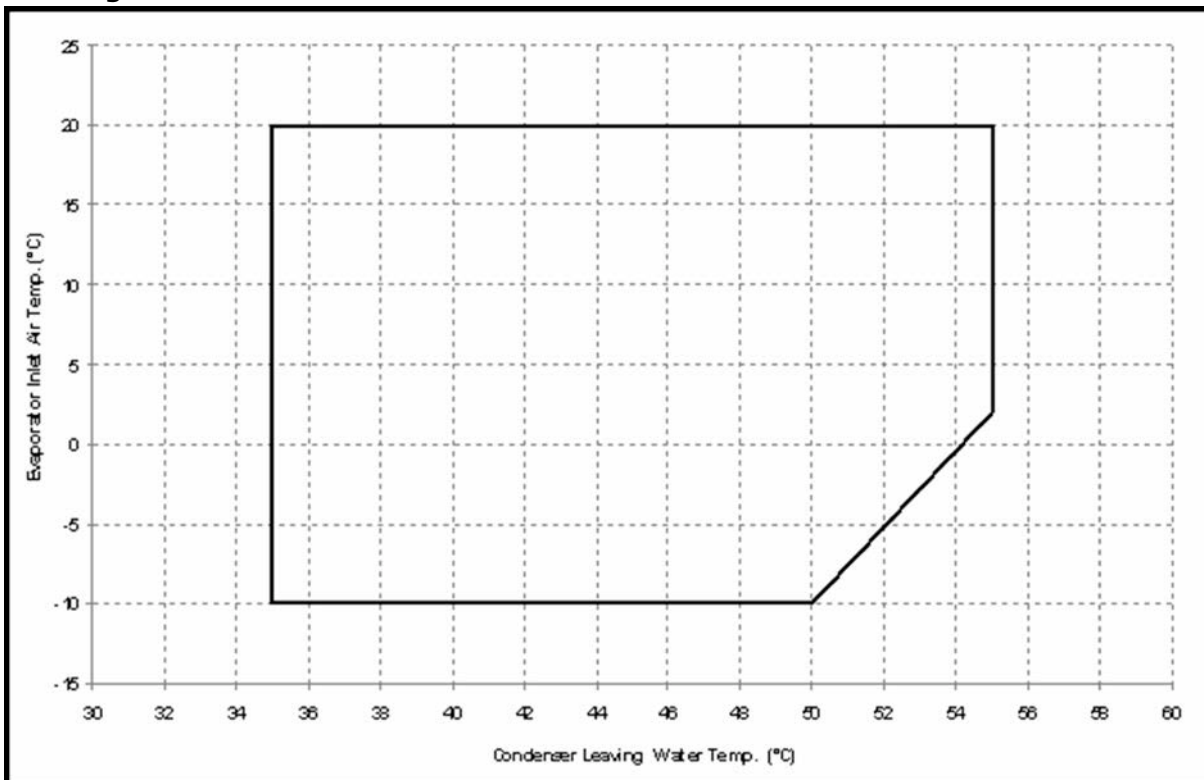

Note

The above graphic represents a guideline about the operating limits of the range. Please refer to Chiller Selection Software (CSS) for real operating limits working conditions for each size.

Table 1 - Water heat exchanger - Minimum and maximum water Δt

A - Δt	°C	8
B - Δt	°C	4

Legend:

A = Max evaporator water Δt

B = Min evaporator water Δt

Note: Table referred to Cooling and Heating Mode

Table 2 - Minimum glycol percentage for low air ambient temperature

AAT (2)	-3	-8	-15	-20
A (1)	10%	20%	30%	40%
AAT (2)	-3	-7	-12	-20
B (1)	10%	20%	30%	40%

Legend:

AAT = Air Ambient Temperature (°C) (2)

A = Ethylene glycol (%) (1)

B = Propylene glycol (%) (1)

(1) Minimum glycol percentage to prevent freezing of water circuit at indicated air ambient temperature

(2) Air ambient temperature do exceed the operating limits of the unit, a protection of water circuit may be needed in winter season at non-working conditions.

Water charge, flow and quality

DAE Water quality requirements	Shell&tube + Flooded	BPHE
Ph (25 °C)	6.8 ÷ 8.4	7.5 – 9.0
Electrical conductivity [$\mu\text{S}/\text{cm}$] (25°C)	< 800	< 500
Chloride ion [mg Cl ⁻ / l]	< 150	< 70 (HP ¹); < 300 (CO ²)
Sulphate ion [mg SO ₄ ²⁻ / l]	< 100	< 100
Alkalinity [mg CaCO ₃ / l]	< 100	< 200
Total Hardness [mg CaCO ₃ / l]	< 200	75 ÷ 150
Iron [mg Fe / l]	< 1	< 0.2
Ammonium ion [mg NH ⁴⁺ / l]	< 1	< 0.5
Silica [mg SiO ₂ / l]	< 50	-
Chlorine molecular (mg Cl ₂ /l)	< 5	< 0.5

Note: 1. Heat Pump
2. Cooling Only

Automatic and Manual Boost .- Cooling Mode

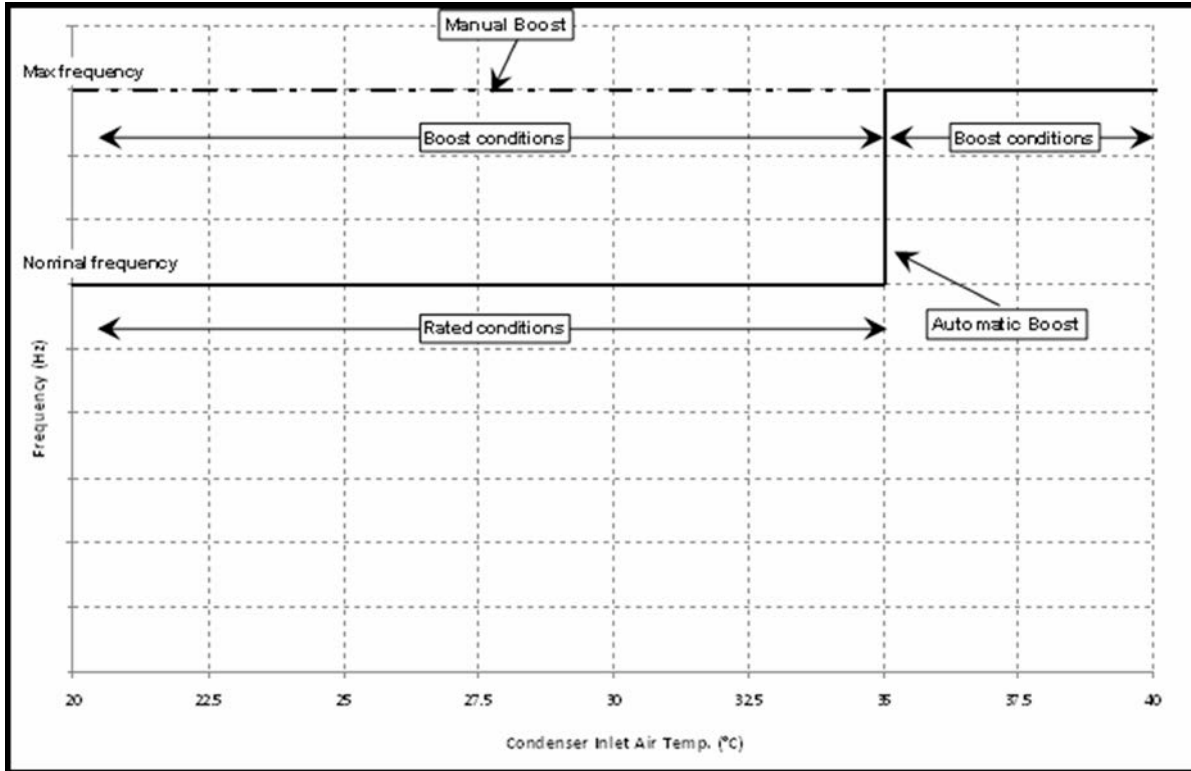

Automatic and Manual Boost .- Heating Mode

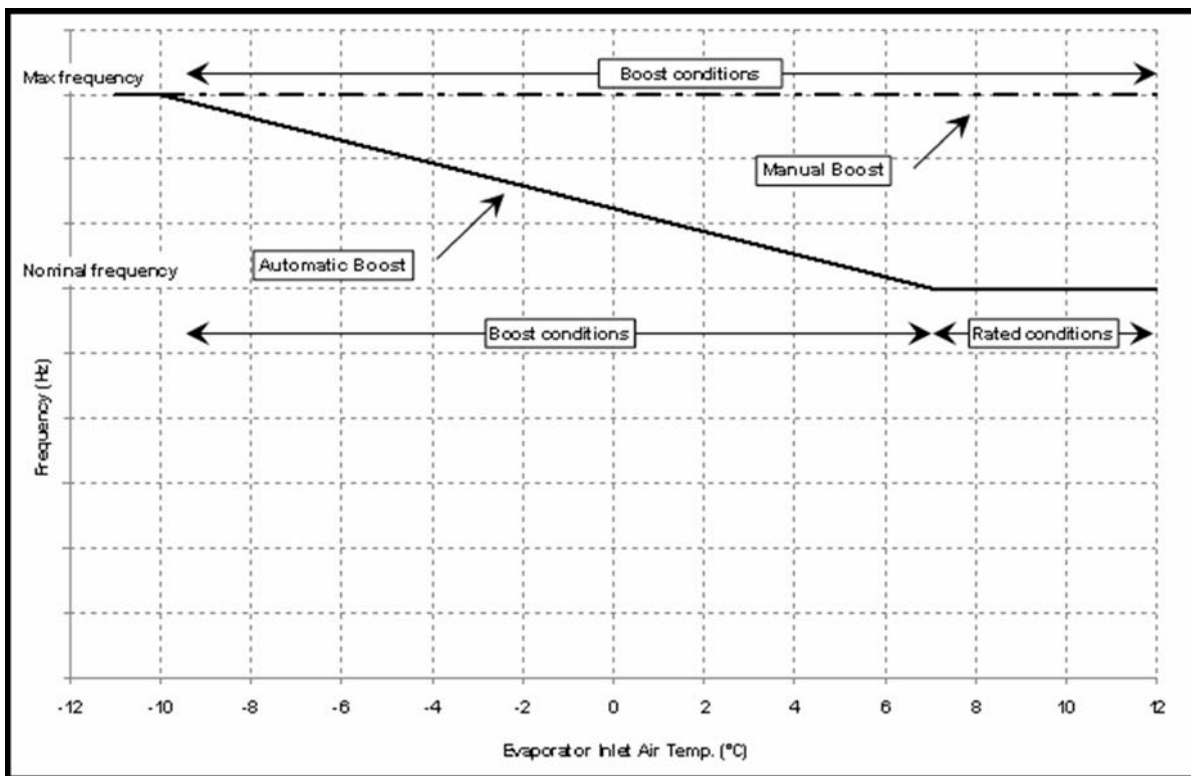

- Automatic boost: unit standard configuration
- Manual boost: customized configuration by different settings
- Rated conditions: compressors are running at nominal frequency
- Boost conditions: compressors are running at the maximum frequency

Heating Capacity correction factors for different evaporator inlet air temperature and relative humidity conditions

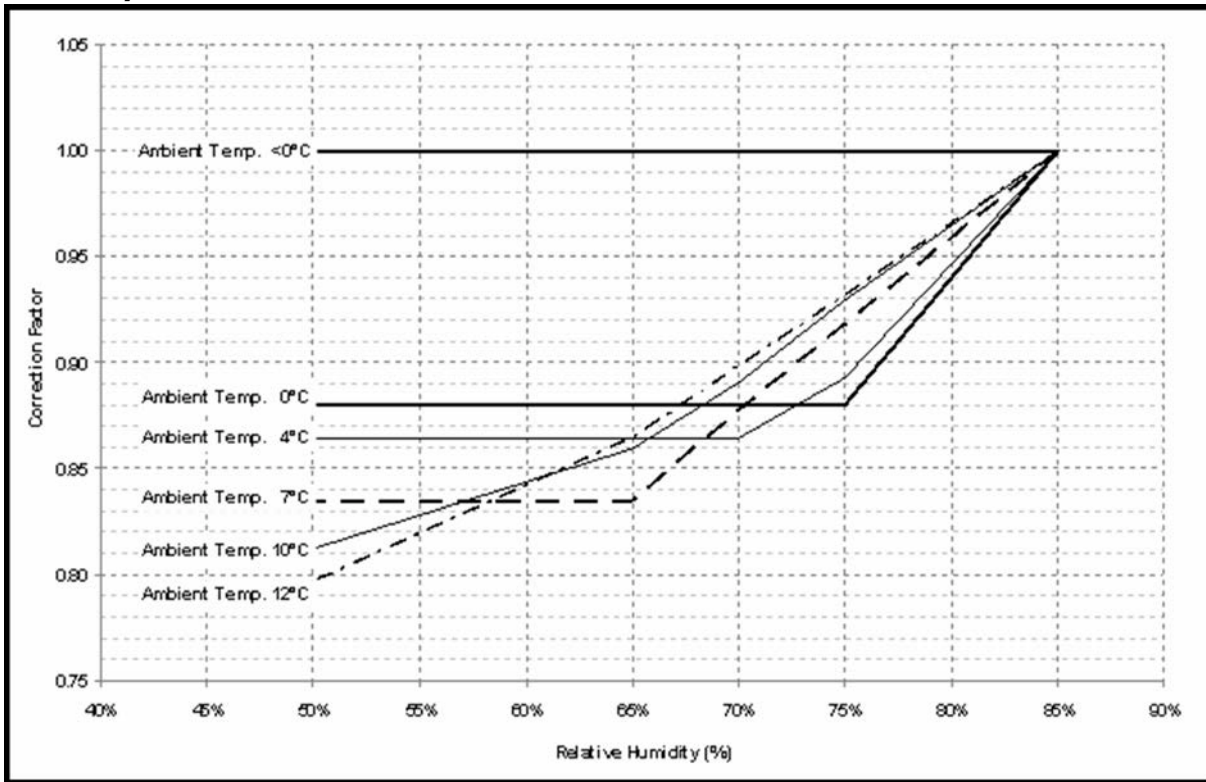

Integrated Heating Capacity - Automatic Boost

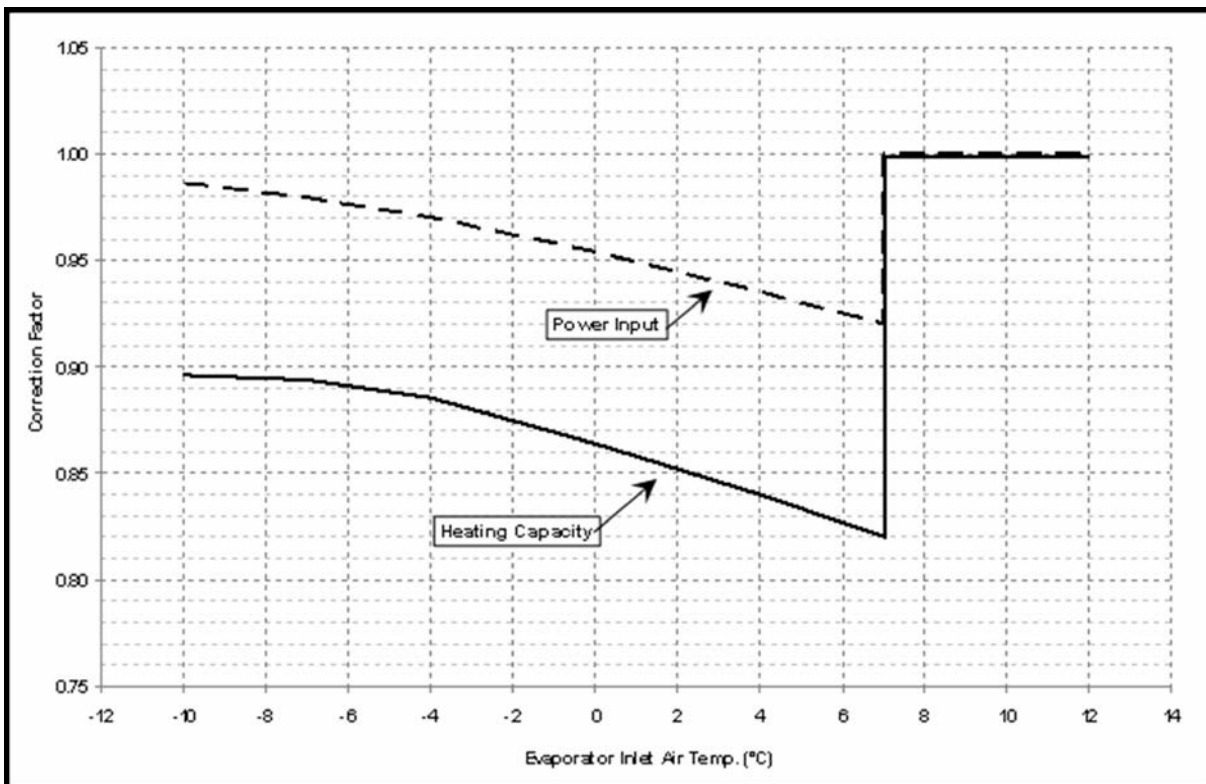

Correction factors to be applied to Standard Ratings in Heating Mode (Relative Humidity: 85% with evaporator inlet air temperature above 0°C ; 100% with evaporator inlet air temperature below 0°C)

Integrated Heating Capacity - Manual Boost

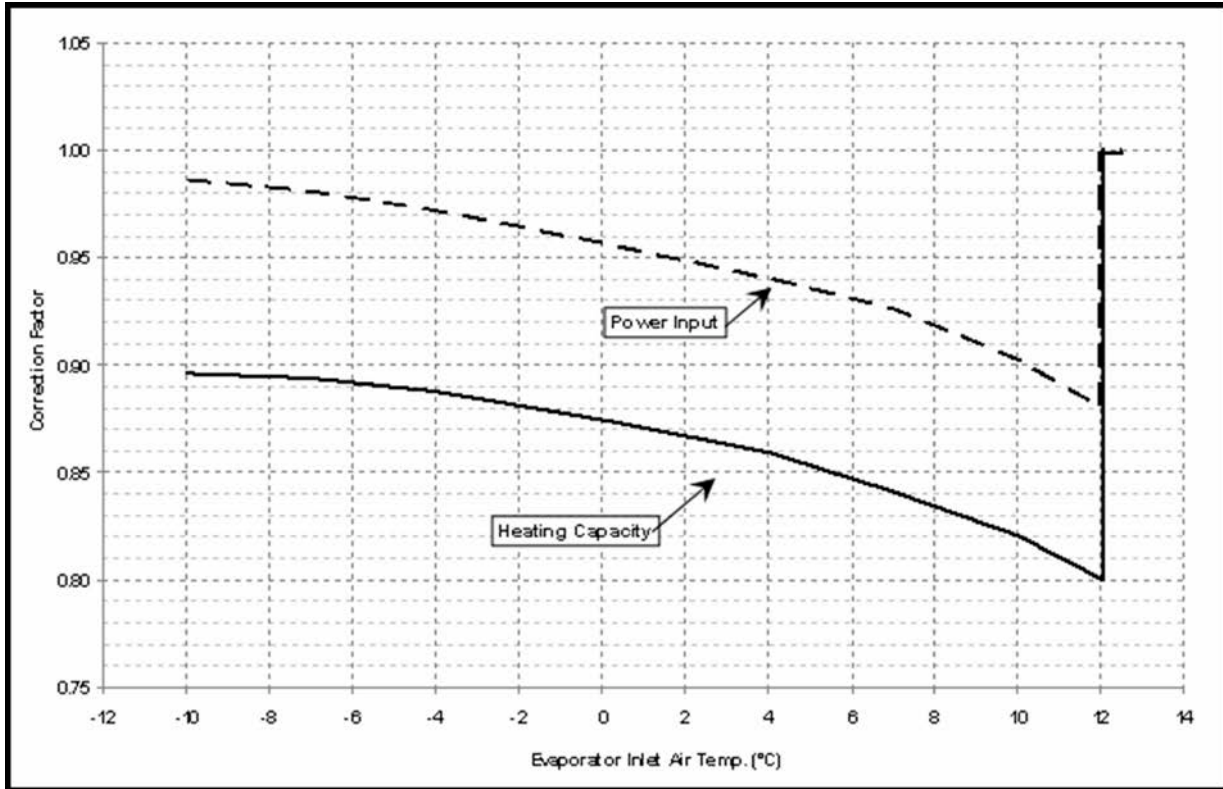

Correction factors to be applied to Standard Ratings in Heating Mode (Relative Humidity: 85% with evaporator inlet air temperature above 0°C ; 100% with evaporator inlet air temperature below 0°)

Water Pump Kit

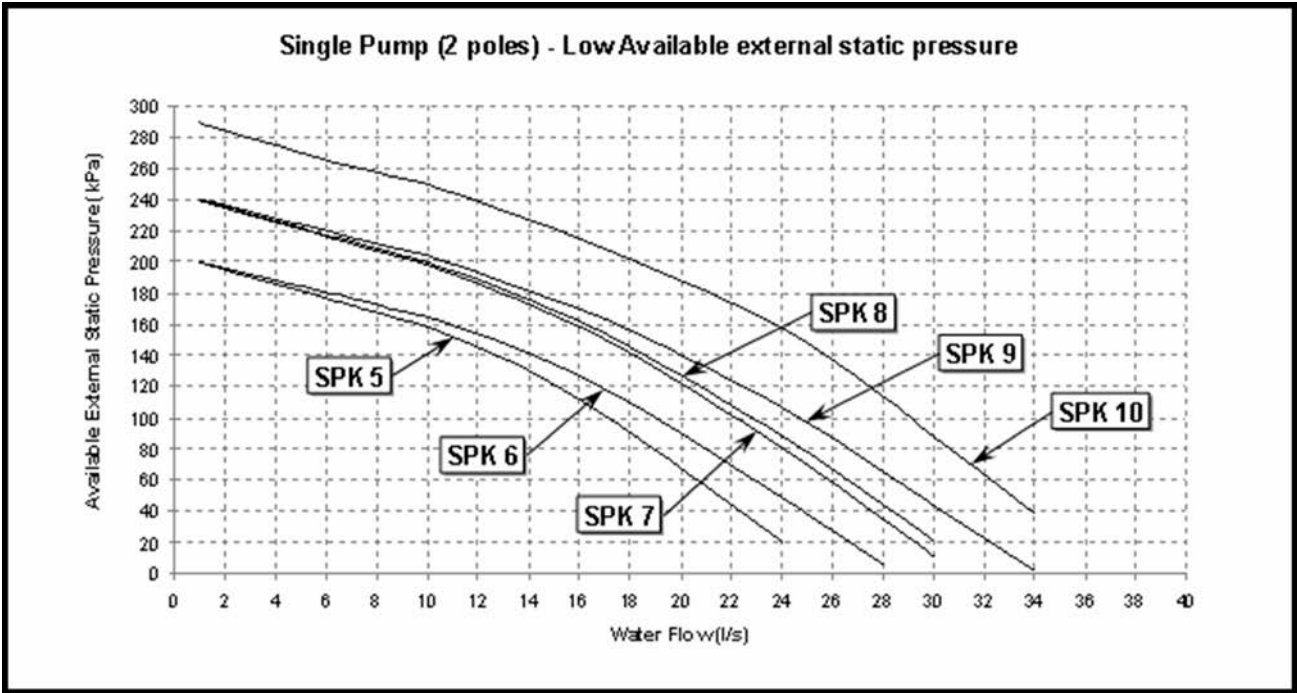
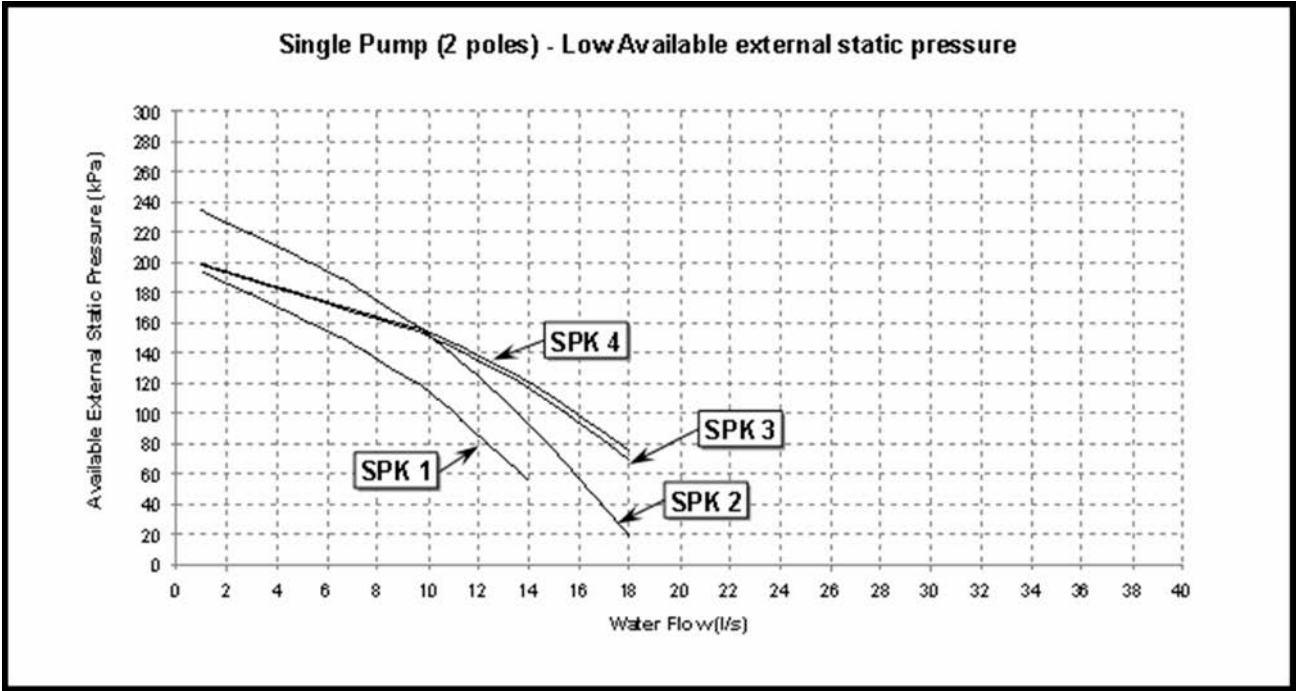

Pump Kit	SPK1	SPK2	SPK3	SPK4		SPK5		SPK6	SPK7	SPK8
Size EWYD-BZSS	250	270	290	320	340	370	380	410	440	460
Size EWYD-BZSL	250	270	290	320	330	360	370	400	430	450

Pump Kit	SPK9	SPK10	
Size EWYD-BZSSB3	510	530	570
Size EWYD-BZSLB3	510	530	570

Note
 - when using mixture of water and glycol please contact the factory as above specification can change

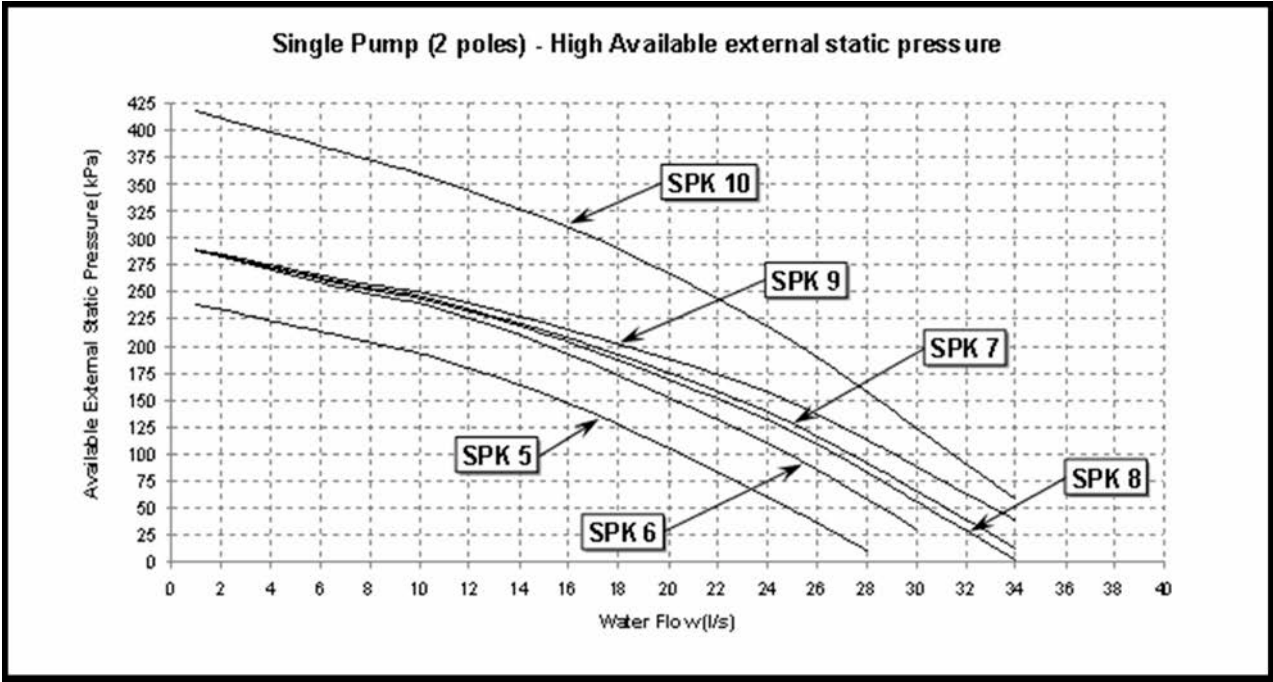
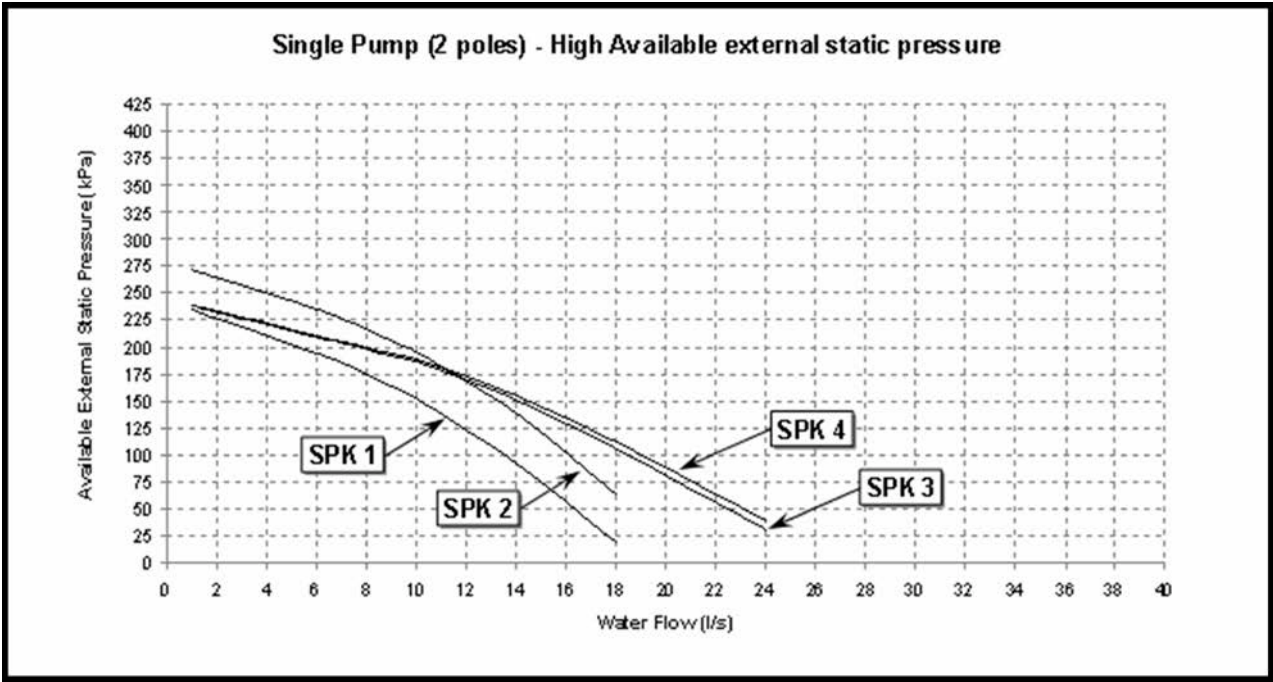

Pump Kit	SPK1	SPK2	SPK3	SPK4		SPK5	SPK6	SPK7		SPK8
Size EWYD-BZSS	250	270	290	320	340	370	380	410	440	460
Size EWYD-BZSL	250	270	290	320	330	360	370	400	430	450

Pump Kit	SPK9	SPK10	
Size EWYD-BZSSB3	510	530	570
Size EWYD-BZSLB3	510	530	570

Note

- when using mixture of water and glycol please contact the factory as above specification can change

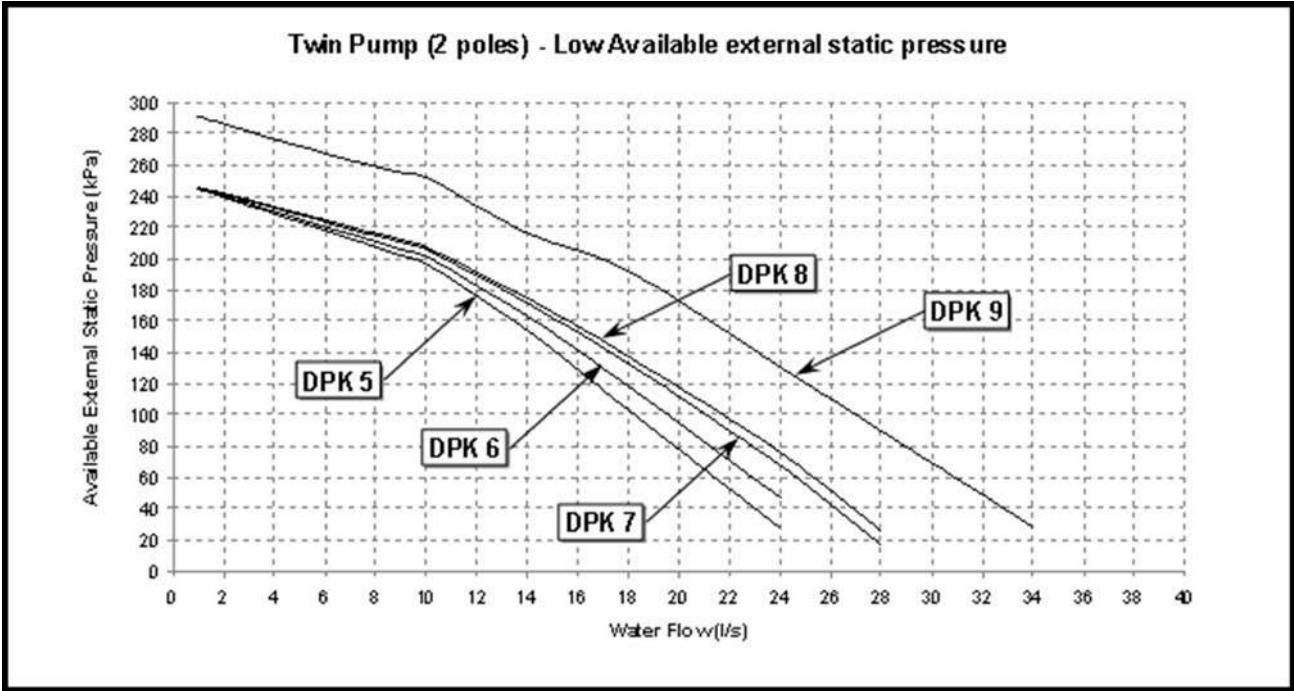
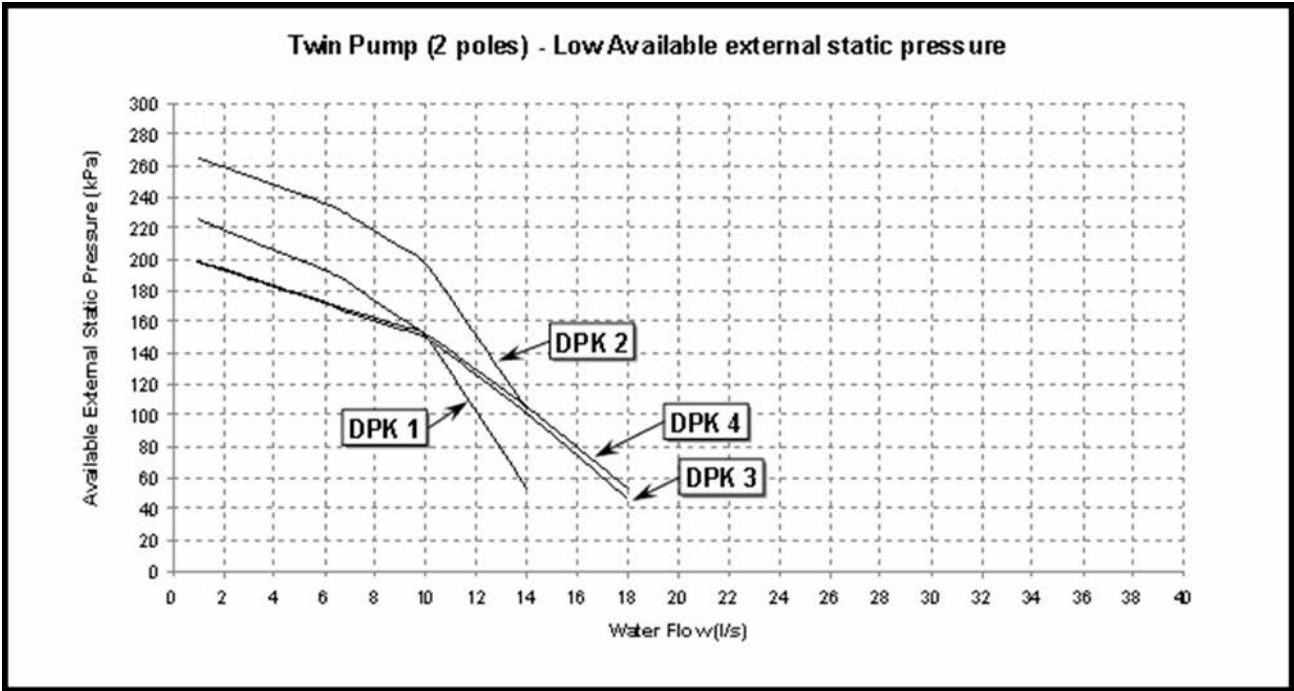

Pump Kit	DPK1	DPK2	DPK3	DPK4	DPK5	DPK6		DPK7		DPK8
Size EWYD-BZSS	250	270	290	320	340	370	380	410	440	460
Size EWYD-BZSL	250	270	290	320	330	360	370	400	430	450

Pump Kit	DPK9		
Size EWYD-BZSSB3	510	530	570
Size EWYD-BZSLB3	510	530	570

Note
 - when using mixture of water and glycol please contact the factory as above specification can change

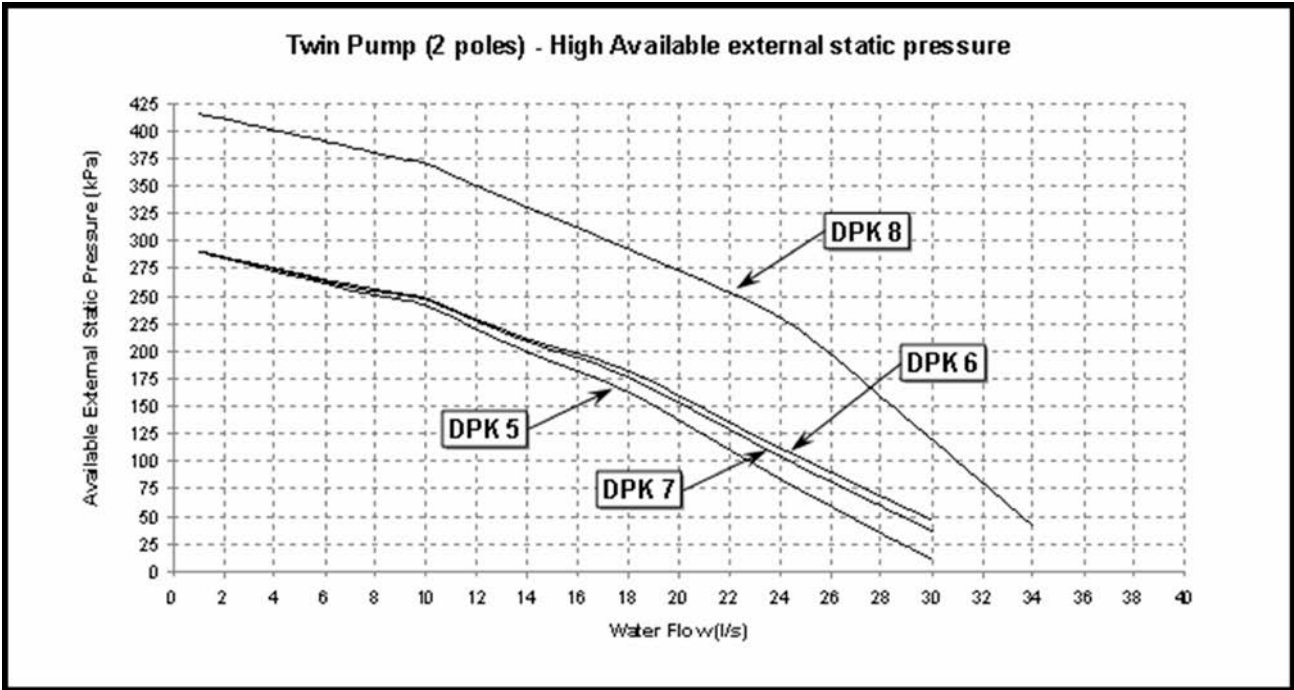
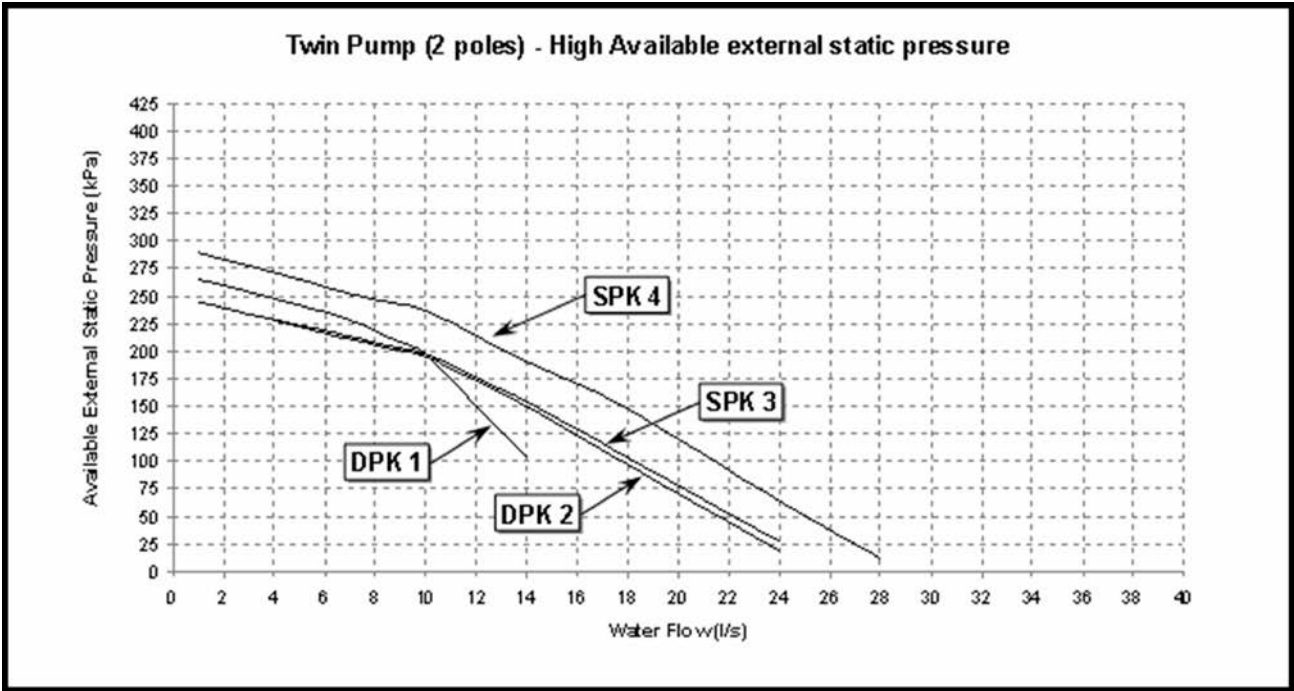

Pump Kit	DPK1	DPK2		DPK3	DPK4	DPK5		DPK6		DPK7
Size EWYD-BZSS	250	270	290	320	340	370	380	410	440	460
Size EWYD-BZSL	250	270	290	320	330	360	370	400	430	450

Pump Kit	DPK8		
Size EWYD-BZSSB3	510	530	570
Size EWYD-BZSLB3	510	530	570

Note

- when using mixture of water and glycol please contact the factory as above specification can change

Water Pump Kit - Technical Information

		Pump Motor Power (kW)	Pump Motor Current (A)	Power supply (V-ph-Hz)	PN	Motor Protection	Insulation (Class)	Working Temp. (°C)
Single Pump Low Available Static Pressure	SPK 1	2.2	5.0	400V-3ph-50hz	10	IP55	Class F	-10 + 130
	SPK 2	3.0	6.3	400V-3ph-50hz	10	IP55	Class F	-10 + 130
	SPK 3	4.0	7.7	400V-3ph-50hz	10	IP55	Class F	-10 + 130
	SPK 4	4.0	7.7	400V-3ph-50hz	10	IP55	Class F	-10 + 130
	SPK 5	4.0	7.7	400V-3ph-50hz	10	IP55	Class F	-10 + 130
	SPK 6	4.0	7.7	400V-3ph-50hz	10	IP55	Class F	-10 + 130
	SPK 7	5.5	10.4	400V-3ph-50hz	10	IP55	Class F	-10 + 130
	SPK 8	5.5	10.4	400V-3ph-50hz	10	IP55	Class F	-10 + 130
	SPK 9	5.5	10.4	400V-3ph-50hz	10	IP55	Class F	-10 + 130
	SPK 10	7.5	13.9	400V-3ph-50hz	10	IP55	Class F	-10 + 130
Single Pump High Available Static Pressure	SPK 1	3.0	6.3	400V-3ph-50hz	10	IP55	Class F	-10 + 130
	SPK 2	4.0	7.7	400V-3ph-50hz	10	IP55	Class F	-10 + 130
	SPK 3	5.5	10.4	400V-3ph-50hz	10	IP55	Class F	-10 + 130
	SPK 4	5.5	10.4	400V-3ph-50hz	10	IP55	Class F	-10 + 130
	SPK 5	5.5	10.4	400V-3ph-50hz	10	IP55	Class F	-10 + 130
	SPK 6	7.5	13.9	400V-3ph-50hz	10	IP55	Class F	-10 + 130
	SPK 7	7.5	13.9	400V-3ph-50hz	10	IP55	Class F	-10 + 130
	SPK 8	7.5	13.9	400V-3ph-50hz	10	IP55	Class F	-10 + 130
	SPK 9	7.5	13.9	400V-3ph-50hz	10	IP55	Class F	-10 + 130
	SPK 10	11.0	20.2	400V-3ph-50hz	10	IP55	Class F	-10 + 130

		Pump Motor Power (kW)	Pump Motor Current (A)	Power supply (V-ph-Hz)	PN	Motor Protection	Insulation (Class)	Working Temp. (°C)
Single Pump High Available Static Pressure	SPK 1	3.0	6.3	400V-3ph-50hz	10	IP55	Class F	-10 + 130
	SPK 2	4.0	7.7	400V-3ph-50hz	10	IP55	Class F	-10 + 130
	SPK 3	5.5	10.4	400V-3ph-50hz	10	IP55	Class F	-10 + 130
	SPK 4	5.5	10.4	400V-3ph-50hz	10	IP55	Class F	-10 + 130
	SPK 5	5.5	10.4	400V-3ph-50hz	10	IP55	Class F	-10 + 130
	SPK 6	7.5	13.9	400V-3ph-50hz	10	IP55	Class F	-10 + 130
	SPK 7	7.5	13.9	400V-3ph-50hz	10	IP55	Class F	-10 + 130
	SPK 8	7.5	13.9	400V-3ph-50hz	10	IP55	Class F	-10 + 130
	SPK 9	7.5	13.9	400V-3ph-50hz	10	IP55	Class F	-10 + 130
	SPK 10	11.0	20.2	400V-3ph-50hz	10	IP55	Class F	-10 + 130
Double Pump High Available Static Pressure	DPK 1	4.0	7.7	400V-3ph-50hz	10	IP55	Class F	-10 + 130
	DPK 2	5.5	10.4	400V-3ph-50hz	10	IP55	Class F	-10 + 130
	DPK 3	5.5	10.4	400V-3ph-50hz	10	IP55	Class F	-10 + 130
	DPK 4	7.5	13.9	400V-3ph-50hz	10	IP55	Class F	-10 + 130
	DPK 5	7.5	13.9	400V-3ph-50hz	10	IP55	Class F	-10 + 130
	DPK 6	7.5	13.9	400V-3ph-50hz	10	IP55	Class F	-10 + 130
	DPK 7	7.5	13.9	400V-3ph-50hz	10	IP55	Class F	-10 + 130
	DPK 8	11.0	20.2	400V-3ph-50hz	10	IP55	Class F	-10 + 130
	DPK 9	11.0	20.2	400V-3ph-50hz	10	IP55	Class F	-10 + 130

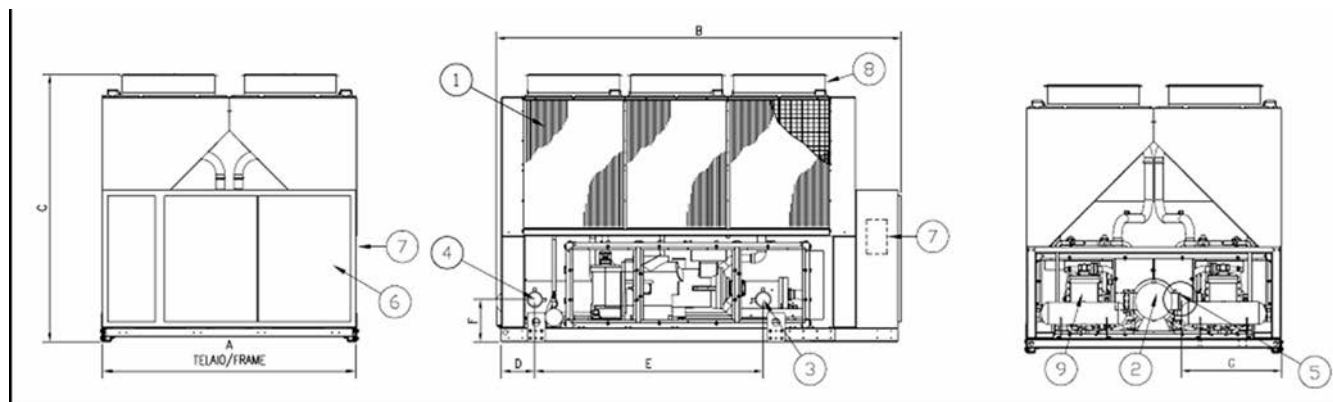

LEGEND

- 1: Air heat exchanger (condenser – evaporator)
- 2: Water heat exchanger (evaporator – condenser)
- 3: Evaporator water inlet
- 4: Evaporator water outlet
- 5: Victaulic connection
- 6: Electrical control panel
- 7: Slot for power and control connection
- 8: Fan
- 9: Compressor

	A	B	C	D	E	F	G
EWYD250BZSS	2254	3547	2335	288	2000	369	882
EWYD270BZSS	2254	3547	2335	288	2000	369	882
EWYD290BZSS	2254	3547	2335	288	2000	369	882
EWYD320BZSS	2254	4428	2335	289	2000	449	882
EWYD340BZSS	2254	4428	2335	289	2000	449	882
EWYD370BZSS	2254	4428	2335	289	2000	449	882
EWYD380BZSS	2254	4428	2335	289	2000	449	882
EWYD410BZSS	2254	5329	2335	1190	2000	448	852
EWYD440BZSS	2254	5329	2335	1190	2000	448	852
EWYD460BZSS	2254	6659	2280	346	1996	502	710
EWYD510BZSSB3	2254	6659	2280	346	1996	502	710
EWYD530BZSSB3	2254	6659	2280	346	1996	502	710
EWYD570BZSSB3	2254	6659	2280	346	1996	502	710
EWYD250BZSL	2254	3547	2335	288	2000	369	882
EWYD270BZSL	2254	3547	2335	288	2000	369	882
EWYD290BZSL	2254	3547	2335	288	2000	369	882
EWYD320BZSL	2254	4428	2335	289	2000	449	882
EWYD330BZSL	2254	4428	2335	289	2000	449	882
EWYD360BZSL	2254	4428	2335	289	2000	449	882
EWYD370BZSL	2254	4428	2335	289	2000	449	882
EWYD400BZSL	2254	5329	2335	1190	2000	448	852
EWYD430BZSL	2254	5329	2335	1190	2000	448	852
EWYD450BZSL	2254	6659	2280	346	1996	502	710
EWYD510BZSLB3	2254	6659	2280	346	1996	502	710
EWYD530BZSLB3	2254	6659	2280	346	1996	502	710
EWYD570BZSLB3	2254	6659	2280	346	1996	502	710

Warning Installation and maintenance of the unit must to be performed only by qualified personnel who have knowledge with local codes and regulations, and experience with this type of equipment. Must be avoided the unit installation in places that could be considered dangerous for all the maintenance operations.

Handling Care should be taken to avoid rough handling or shock due to dropping the unit. Do not push or pull the unit from anything other than the base frame. Never allow the unit to fall during unloading or moving as this may result in serious damage. To lift the unit, rings are provided in the base frame of the unit. Spreader bar and cables should be arranged to prevent damage to the condenser coil or unit cabinet.

Location The units are produced for outside installation on roofs, floors or below ground level on condition that the area is free from obstacles for the passage of the condenser air. The unit should be positioned on solid foundations and perfectly level; in the case of installation on roofs or floors, it may be advisable to arrange the use of suitable weight distribution beams. When the units are installed on the ground, a concrete base at least 250 mm wider and longer than the unit's footprint should be laid. Furthermore, this base should withstand the unit weight mentioned in the technical data table.

Space requirements The units are air-cooled, then it is important to respect the minimum distances which guarantee the best ventilation of the condenser coils. Limitations of space reducing the air flow could cause significant reductions in cooling capacity and an increase in electricity consumption.

To determinate unit placement, careful consideration must be given to assure a sufficient air flow across the condenser heat transfer surface. Two conditions must be avoided to achieve the best performance: warm air recirculation and coil starvation.

Both these conditions cause an increase of condensing pressures that results in reductions in unit efficiency and capacity.

Moreover the unique microprocessor has the ability to calculate the operating environment of the air cooled chiller and the capacity to optimize its performance staying on-line during abnormal conditions.

Each side of the unit must be accessible after installation for periodic service. 'Fig.1' shows you minimum recommended clearance requirements.

Vertical condenser air discharge must be unobstructed because the unit would have its capacity and efficiency significantly reduced.

If the units are positioned in places surrounded by walls or obstacles of the same height as the units, the units should follow the minimum recommended clearance requirements shown in 'Fig.2'. In the event the obstacles are higher than the units, the minimum recommended clearance requirements are shown in 'Fig.3'. Units installed closer than the minimum recommended distance to a wall or other vertical riser may experience a combination of coil starvation and warm air recirculation, thus causing reduction in unit capacity and efficiency reductions. The microprocessor control is proactive in response "of design condition". In the case of single or compounded influences restricting airflow to the unit, the microprocessor will act to keep the compressor(s) running (at reduced capacity) rather than allowing a shut-off on high discharge pressure.

When two or more units are positioned side by side it is recommended that the condenser coils are at a minimum distance from one another as shown in 'Fig.4'; strong wind could be the cause of air warm recirculation.

For other installation solutions, consult our technicians.

The above recommended information are representative of general installation. A specific evaluation should be done by contractor depending on the case.

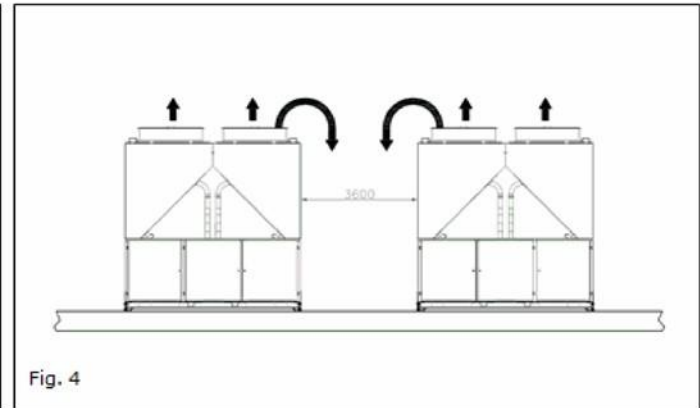
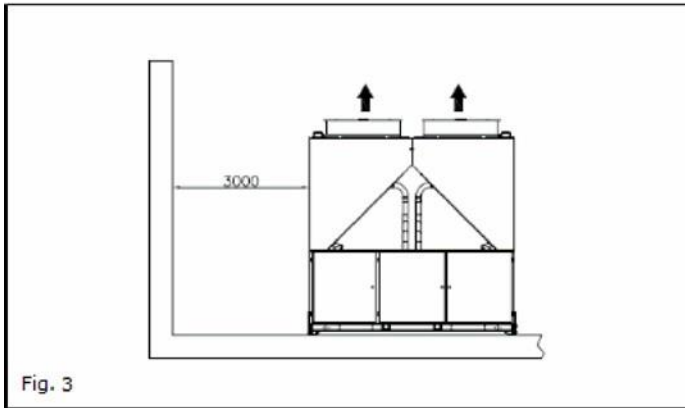
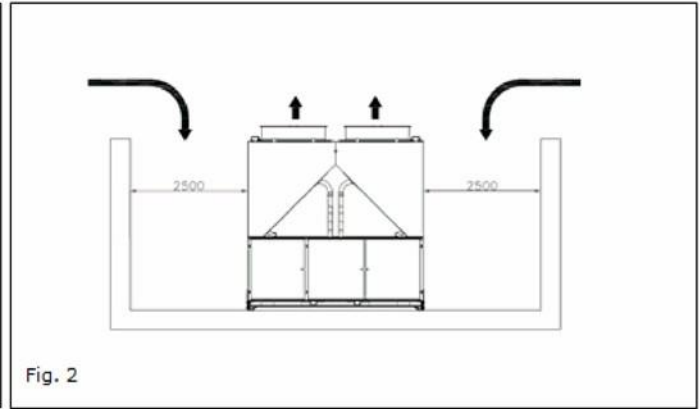
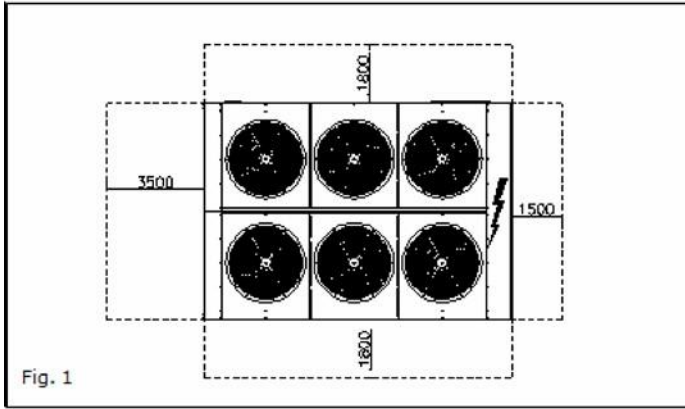

Acoustic protection When noise level must meet special requirements, it is necessary to pay the maximum attention to ensure the perfect insulation of the unit from the support base by applying appropriate vibration-dampening devices on the unit, on the water pipes and on the electrical connections.

Storage The environment conditions have to be in the following limits:

Minimum ambient temperature:	-20°C
Maximum ambient temperature:	+57°C
Maximum R.H.:	95% not condensing

General The Air to Water Heat Pump will be designed and manufactured in accordance with the following European directives:

- Construction of pressure vessel 97/23/EC (PED)
- Machinery Directive 2006/42/EC
- Low Voltage 2006/95/EC
- Electromagnetic Compatibility 2004/108/EC
- Electrical & Safety codes EN 60204-1 / EN 60335-2-40
- Manufacturing Quality Standards UNI – EN ISO 9001:2004

To avoid any losses, the unit will be tested at full load in the factory (at the nominal working conditions and water temperatures). The Air to Water Heat Pump will be delivered to the job site completely assembled and charged with refrigerant and oil. The installation of the Air to Water Heat Pump must comply with the manufacturer’s instructions for rigging and handling equipment.

The unit will be able to start up and operate (as standard) at full load with:

- outside air temperature from °C to..... °C
- evaporator leaving fluid temperature between °C and °C

Refrigerant Only HFC 134a can be used.

Performance

- Number of air to water heat pumps:
- Cooling capacity for single air to water heat pumpkW
- Power input for single air to water heat pump in cooling mode kW
- Shell & tube heat exchanger entering water temperature in cooling mode..... °C
- Shell & tube heat exchanger leaving water temperature in cooling mode °C
- Shell & tube heat exchanger water flow..... l/s
- Nominal outside working ambient temperature in cooling mode..... °C

- Heating capacity for single air to water heat pump kW
- Power input for single air to water heat pump in heating mode.....kW
- Shell & tube heat exchanger entering water temperature in heating mode °C
- Shell & tube heat exchanger leaving water temperature in heating mode..... °C
- Shell & tube heat exchanger water flow..... l/s
- Nominal outside working ambient temperature in heating mode °C

• The unit should work with electricity in range 400 V ±10%, 3ph, 50Hz without neutral and shall only have one power connection point. The control circuit voltage shall be 24 V maximum, supplied by a factory-installed transformer.

Unit description The unit shall include as standard not less than: two or three independent refrigerant circuits, semi-hermetic rotary single screw compressors, air-cooled variable electrical frequency driver for each compressor (VFD), electronic expansion device (EEXV), refrigerant direct expansion shell & tube heat exchanger, air-cooled condenser section, R134a refrigerant, lubrication system, motor starting components, suction line shut-off valve, discharge line shut-off valve, control system and all components necessary for safe and stable unit operation.

The unit will be factory assembled on a robust base-frame made of zinc coated steel, protected by an epoxy paint

Sound level and vibrations Sound pressure level at 1 meter distance in free field, semispheric conditions, shall not exceeddB(A). The sound pressure levels must be rated in accordance to ISO 3744 (other types of rating can not be used). Vibration on the base frame should not exceed 2 mm/s.

Dimensions Unit dimensions shall not exceed following indications:

- Unit length mm
- Unit widthmm
- Unit height mm

HEAT PUMP Components

Compressors

- Semi-hermetic, single-screw type with one main helical rotor meshing with gaterotor. The gaterotor will be constructed of a carbon impregnated engineered composite material. The gaterotor supports will be constructed of cast iron.
- The oil injection shall be used in order to get high EER (Energy Efficiency Ratio) also at high condensing pressure and low sound pressure levels in each load condition.
- Refrigerant system differential pressure shall provide oil flow through service replaceable, 0.5 micron, full flow, cartridge type oil filter internal to compressor.
- Refrigerant system differential pressure shall provide oil injection on all moving compressor parts to correctly lubricate them. Electrical oil pump lubricating system is not acceptable.
- The compressor's oil cooling must be realized, when necessary, by refrigerant liquid injection. External dedicated heat exchanger and additional piping to carry the oil from the compressor to heat exchanger and viceversa will be not accepted.
- The compressor shall be provided with an integrated, high efficiency, cyclonic type oil separator and with built-in oil filter, cartridge type.
- The compressor shall be direct electrical driven, without gear transmission between the screw and the electrical motor.
- The compressor casing shall be provided with ports to realize economized refrigerant cycles.
- Shall be present two thermal protection realized by a thermistor for high temperature protection: one temperature sensor to protect electrical motor and another sensor to protect unit and lubricating oil from high discharge gas temperature.
- The compressor shall be equipped with an electric oil-crankcase heater.
- Compressor shall be fully field serviceable. Compressor that must be removed and returned to the factory for service shall be unacceptable.

Cooling capacity control system

- Each unit will have a microprocessor for the control of compressor inverter position and the instantaneous RPM value of the motor.
 - The unit capacity control shall be infinitely modulating, both in cooling and in heating mode, from 100% down to 30% for each compressor (from 100% down to 13% of full load for units with 2 compressors and 9% of full load for units with 3 compressors).
 - Step unloading unacceptable because of evaporator leaving water temperature fluctuation and low unit efficiency at partial load.
 - The system shall stage the unit based on the leaving evaporator water temperature that shall be controlled by a PID (Proportional Integral Derivative) loop.
 - Unit control logic shall to manage frequency level of the compressor electric motor to exactly match plant load request in order to keep constant the set point for delivered chilled or hot water temperature.
 - In this operating condition unit control logic shall modulate electrical frequency level in a range lower and upper the nominal electrical network value fixed at 50 Hz.
 - The microprocessor unit control shall detect conditions that approach protective limits and take self-corrective action prior to an alarm occurring. The system shall automatically reduce chiller capacity when any of the following parameters are outside their normal operating range:
 - High condenser pressure
 - Low evaporation refrigerant temperature
 - High compressor motor amps
 - Ait ro water heat pump shall be able to deliver heating capacity (with -5°C outside ambient temperature) close to its nominal cooling capacity related at +35°C outside ambient temperature with +7°C for set-point of the leaving evaporator chilled water. In this condition unit shall be able to deliver 45°C hot water.
- Unit-Mounted Variable Frequency Driver (VFD) and Electrical Requirement

- All interconnecting wiring between the VFD and the chiller shall be factory-installed. Customer electrical connection for compressor motor power shall be limited to main power leads to the single point power connection located into electrical panel.
- The VFD shall be air cooled type. Water cooled design or refrigerant cooled design are not acceptable.
- The VFD full load efficiency shall meet or exceed 97% at 100% VFD rated capacity.
- Base motor frequency shall permit motor to be utilized at nameplate voltage. Adjustable frequency range, monitored by unit's microprocessor control, shall permit a stable unit capacity control down to 13% (9% with 3 compressor unit) without hot-gas bypass.
- Starting current for the compressor shall not exceed nominal compressor load amps.
- Unit power factor shall be not less than 0.95 on entire unit capacity range, from 100% down to 13% (9% with 3 compressor unit).

Evaporator

- The units shall be supplied with shell and tubes counter-flow heat exchanger with single refrigerant pass. It will be refrigerant direct expansion type with refrigerant inside the tubes and water outside (shell side). It will include carbon steel tube sheets, with straight copper tubes internally wound for higher efficiencies, expanded on the tube plates.
- The external shell shall be linked with an electrical heater to prevent freezing down to -28°C ambient temperature, commanded by a thermostat and shall be insulated with flexible, closed cell polyurethane insulation material (10-mm thick).
- The evaporator will have 2 or 3 circuits, one for each compressor and shall be single refrigerant pass.
- The water connections shall be VICTAULIC type connections as standard to ensure quick mechanical disconnection between the unit and the hydronic network.
- Evaporator is manufactured in accordance to PED approval.

Condenser coil

- The condenser coils are constructed with internally finned seamless copper tubes having a "W" configuration and arranged in a staggered row pattern and mechanically expanded into lanced and rippled aluminium fins with full fin collars for higher efficiencies. The space between the fins are given by a collar that will increase the surface area in connection with the tubes, protecting them from ambient corrosion.
- The coils will have an integral subcooler circuit that provides sufficient subcooling to effectively eliminate the possibility of liquid flashing and increase the unit's efficiency of 5-7% without increasing in power absorption.
- The condenser coil shall be leak-tested and submitted to a pressure test with dry air.

Condenser fans

- The fans used in conjunction with the condenser coils, shall be propeller type with high efficiency design blades to maximize performances and lower noise. The material of the blades is glass reinforced resin and each fan is protected by a guard.
- The air discharge shall be vertical and each fan must be coupled to the electrical motor. Fan motor will be thermally protected (as standard) by internal thermal motor and protected by circuit breaker installed inside the electrical panel as a standard. The motor will be IP54.
- They shall have individual overload protection via a disconnect switch.

Refrigerant circuit

- The unit must have refrigerant circuits completely independent of each other with one compressor and one variable electrical frequency driver per circuit (VFD).
- Each circuit shall include as standard: electronic expansion device piloted by unit's microprocessor control, compressor discharge shut-off valve, suction line shut-off valve, 4-way valve to reverse refrigerant cycle into the unit, liquid line shut-off valve with charging connection, replaceable core filter-drier, sight glass with moisture indicator and insulated suction line.

Condensation control

- The units will be provided with an automatic control for condensing pressure which ensures the working at low external temperatures down to +10 °C, thanks the ON/OFF of the condenser fans, to maintain condensing pressure. Fan speed control, to allow unit's operation with very low ambient temperature (-18°C), should be available as option.
- Automatic compressor unloading when abnormal high condensing pressure is detected to prevent the shutdown of the refrigerant circuit (shutdown of the unit) due to a high-pressure fault.

Low Noise unit options (on request)

- The unit compressors shall be connected with unit's metal baseframe by rubber antivibration supports to prevent the transmission of vibrations to all metal unit structure and so to control the unit noise.
- The discharge and suction lines shall be provided with mufflers to eliminate vibration and so to reduce the noise unit emission.
- The chiller shall be provided with an acoustically compressor enclosure. This enclosure shall be realized with a light, corrosion resisting aluminium structure and metal panels. The compressors sound-proof enclosure shall be internally fitted with flexible, multi layer, high density materials. The middle layer is 3 mm, very high density and high efficiency noise reduction material. The enclosure shall be carefully assembled to avoid decreasing of its noise reduction power.
- The chiller shall be provided with very low speed condenser fans and with an improved condenser section.

Control panel

- Field power connection, control interlock terminals, and unit control system should be centrally located in an electric panel (IP 54). Power and starting controls should be separate from safety and operating controls in different compartments of the same panel.
- Starting will be star/delta type.
- Power and starting controls should include fuses and contactors for each compressor winding and fan motors. Operating and safety controls should include energy saving control; emergency stop switch; overload protection for compressor motor; high and low pressure cut-out switch (for each refrigerant circuit); anti-freeze thermostat; cut-out switch for each compressor.
- All of the information regarding the unit will be reported on a display and with the internal built-in calendar and clock that will switch the unit ON/OFF during day time all year long.
- The following features and functions shall be included:
 - resetting chilled water temperature by controlling the return water temperature or by a remote 4-20 mA DC signal or by controlling the external ambient temperature;
 - soft load function to prevent the system from operating at full load during the chilled fluid pulldown period;
 - password protection of critical parameters of control;
 - start-to-start and stop-to-start timers to provide minimum compressor off-time with maximum motor protection;
 - communication capability with a PC or remote monitoring;
 - discharge pressure control through intelligent cycling of condenser fans;
 - lead-lag selection by manual or automatically by circuit run hours;
 - double set point for brine unit version;
 - scheduling via internal time clock to allow programming of a yearly start-stop schedule accommodating weekends and holidays.

Optional High Level Communications Interface

The controller as a minimum shall be capable of providing the data shown in the above list and document entitled McQuaycomms, using the following options:

- Option A RS485 Serial card
- Option B RS232 Serial card
- Option C LonWorks interface to FTT10A Transceiver
- Option D Bacnet Compatible



The present leaflet is drawn up by way of information only and does not constitute an offer binding upon Daikin Europe NV. Daikin Europe NV, has compiled the content of this leaflet to the best of its knowledge. No express or implied warranty is given for the completeness, accuracy, reliability or fitness for particular purpose of its content and the products and services presented therein. Specifications are subject to change without prior notice. Daikin Europe NV, explicitly rejects any liability for any direct or indirect damage, in the broadest sense, arising from or related to the use and/or interpretation of this leaflet. All content is copyrighted by Daikin Europe NV.



www.eurovent-certification.com
www.certiflash.com

Daikin products are distributed by: