

Applied Systems
Technical Data

EWYQ-BVP



- > EWYQ004BVP
- > EWYQ005BVP
- > EWYQ006BVP
- > EWYQ008BVP

TABLE OF CONTENTS

EWYQ-BVP

1	Features	2
2	Specifications	3
	Technical Specifications	3
	Electrical Specifications	8
3	Electrical data	9
4	Options	12
5	Capacity tables	13
	Cooling Capacity Tables	13
	Heating Capacity Tables	15
6	Dimensional drawings	17
7	Piping diagrams	21
8	Wiring diagrams	22
	Wiring Diagrams - Single Phase	22
9	External connection diagrams	29
10	Sound data	30
	Sound Pressure Spectrum - Cooling	30
	Sound Pressure Spectrum - Heating	31
11	Installation	32
	Installation Method	32
12	Operation range	33
13	Hydraulic performance	35
	Static Pressure Drop Unit	35

1 Features

- Top energy efficiency in the market for both cooling and heating up to 3.15 for EER, up to 5.25 for ESEER and up to 3.33 for COP!
- Top energy efficiency in the market for both cooling and heating: up to 3.14 for EER, up to 5.25 for ESEER and up to 3.44 for COP !
- Top product in terms of energy efficiency and operation range
- All capacities available in 2 versions: standard version and version with OP10 option (no freeze up of water when not in operation thanks to the water piping heater tape)
- Easy 'plug and play' installation
- Amongst the most quiet units in the market (63dBA - sound power)
- Single phase power supply and low starting currents make the unit ideal for residential applications
- Weight reduced with 20% compared with the previous models.
- Built-in Hydraulic kit: no buffer tank required, standard inverter driven pump, main flow sensor and switch included.
- Standard wired remote control enables setting of different set points (cooling, heating, water leaving temperature) or based on outdoor conditions (weather dependent control). It has an alarm history, night time noise reduction function and is language based.



Inverter



Swing compressor



Wired remote control

2 Specifications

2-1 Technical Specifications				EWYQ004BVP	EWYQ005BVP	EWYQ006BVP	EWYQ008BVP	
Cooling capacity	Min.		kW	2.0 (1)		3.0 (1)		
	Nom.		kW	4.00 (1) / 4.01 (2)	4.93 (1) / 5.07 (2)	5.88 (1) / 6.07 (2)	7.95 (1) / 8.23 (2)	
Heating capacity	Min.		kW	2.5 (3)		3.0 (3)		
	Nom.		kW	4.11 (3) / 3.96 (4)	4.99 (3) / 4.99 (4)	6.14 (3) / 6.12 (4)	8.08 (3) / 8.44 (4)	
	Max.		kW	5.1 (3)	6.0 (3)	-		
Power input	Cooling	Nom.	kW	1.27 (1) / 0.840 (2)	1.61 (1) / 1.12 (2)	1.87 (1) / 1.13 (2)	2.57 (1) / 1.65 (2)	
	Heating	Nom.	kW	1.19 (3) / 0.860 (4)	1.46 (3) / 1.09 (4)	1.75 (3) / 1.28 (4)	2.31 (3) / 1.84 (4)	
Capacity control	Method			Variable (inverter)				
EER				3.14 (1) / 4.80 (2)	3.06 (1) / 4.51 (2)	3.15 (1) / 5.35 (2)	3.10 (1) / 4.99 (2)	
COP				3.44 (3) / 4.61 (4)	3.41 (3) / 4.58 (4)	3.51 (3) / 4.77 (4)	3.49 (3) / 4.59 (4)	
ESEER				4.45 (5)	4.49 (5)	5.25 (5)	5.24 (5)	
Space heating general	Air to water unit	Rated airflow (outdoor)	m ³ /h	2,820		2,790	2,960	
	Other	Capacity control		Inverter				
		Pck (Crankcase heater mode)		kW	0.033		0.067	
		Poff (Off mode)		kW	0.008		0.067	
		Psb (Standby mode)		kW	0.008		0.067	
		Pto (Thermostat off)		kW	0.008		0.067	
	Integrated supplementary heater	Psup		kW	-		0.0	

2 Specifications

2-1 Technical Specifications				EWYQ004BVP	EWYQ005BVP	EWYQ006BVP	EWYQ008BVP	
Space heating	Average climate water outlet 55°C	General	Annual energy consumption	kWh	2,833	3,428	3,890	5,219
			η_s (Seasonal space heating efficiency)	%	114	118	124	
			Prated at -10°C	kW	4.0	5.0	6.0	8.0
			Qhe Annual energy consumption (GCV)	Gj	10.2	12.3	14.0	18.8
			SCOP		2.92	3.01	3.19	3.17
			Seasonal space heating eff. class		A+			
		A Condition (-7°CDB/-8°CWB)	Cdh (Degradation heating)		1.0			
			COPd		1.97	2.01	2.03	2.01
			Pdh	kW	3.6	4.6	5.2	6.5
			PERd	%	78.8	80.4	81.2	80.4
		B Condition (2°CDB/1°CWB)	Cdh (Degradation heating)		1.0			
			COPd		2.71	2.85	3.24	3.16
			Pdh	kW	2.2	2.7	3.3	4.3
			PERd	%	108.4	114.0	129.6	126.4
		C Condition (7°CDB/6°CWB)	Cdh (Degradation heating)		1.0		0.9	
			COPd		3.85		4.32	
			Pdh	kW	2.5		2.7	
			PERd	%	154.0		172.8	
	D Condition (12°CDB/11°CWB)	Cdh (Degradation heating)		1.0		0.9		
		COPd		5.55		6.13		
		Pdh	kW	3.4		3.1		
		PERd	%	222.0		245.2		
	Rated heat output supplementary capacity	Tsup (at Tdesign -10°C)	Psup	kW	0.3	1.3	6.0	8.0
			COPd		1.80	1.88	2.03	2.12
		Tbiv (bivalent temperature)	Pdh	kW	3.9	4.9	5.2	6.7
			PERd	%	72.0	75.2	81.2	84.8
			Tbiv	°C	-9		-7	-6
		Tol (temperature operating limit)	COPd		1.74		1.94	
			Pdh	kW	3.7		5.3	
			PERd	%	69.6		77.6	
			TOL	°C	-10		-8	
		WTOL		°C	55		53	
Cold climate water outlet 55°C	General	Annual energy consumption	kWh	4,030	4,902	-		
		η_s (Seasonal space heating efficiency)	%	1		-		
		Prated at -22°C	kW	4	5	-		
		Qhe Annual energy consumption (GCV)	Gj	14.5	17.6	-		
Warm climate water outlet 55°C	General	Annual energy consumption	kWh	1,583	1,898	2,145		
		η_s (Seasonal space heating efficiency)	%	146	152	139		
		Prated at 2°C	kW	4.4	5.5	5.7		
		Qhe Annual energy consumption (GCV)	Gj	5.70	6.83	7.72		

2 Specifications

2-1 Technical Specifications				EWYQ004BVP	EWYQ005BVP	EWYQ006BVP	EWYQ008BVP	
Space heating	Average climate water outlet 35°C	General	Annual energy consumption	kWh	2,096	2,545	3,076	3,928
			ηs (Seasonal space heating efficiency)	%	155	159	158	165
			Prated at -10°C	kW	4.0	5.0	6.0	8.0
			Qhe Annual energy consumption (GCV)	Gj	7.54	9.16	11.1	14.1
			SCOP		3.90	4.03		4.21
			Seasonal space heating eff. class		A++			
			A Condition (-7°CDB/-8°CWB)	Cdh (Degradation heating)		1.0		
		COPd		2.93	2.88	2.65		
		Pdh		kW	3.5	4.4	5.2	6.7
		PERd		%	117.2	115.2	209.2	267.2
		B Condition (2°CDB/1°CWB)	Cdh (Degradation heating)		1.0			
			COPd		3.71	3.90	3.82	4.18
			Pdh	kW	2.2	2.7	3.3	4.3
			PERd	%	148.4	156.0	132.8	172.4
		C Condition (7°CDB/6°CWB)	Cdh (Degradation heating)		1.0	0.9		
			COPd		4.94	5.03	5.98	6.22
			Pdh	kW	2.7		3.7	
			PERd	%	197.6	201.2	147.2	148.4
		D Condition (12°CDB/11°CWB)	Cdh (Degradation heating)		1.0	0.9		
			COPd		6.44	6.48	7.01	7.12
	Pdh		kW	3.0		4.2		
	PERd		%	257.6	259.2	167.2	167.6	
	Rated heat output supplementary capacity	Tbiv (bivalent temperature)	COPd		2.36	2.39	2.68	2.75
			Pdh	kW	4.0	4.9	5.5	6.6
		PERd	%	94.4	95.6	219.2	265.2	
		Tbiv	°C	-10		-8	-6	
		Tol (temperature operating limit)	COPd		2.36	2.39	2.78	2.22
			Pdh	kW	4.0	4.9	5.2	5.8
			PERd	%	94.4	95.6	208.4	233.2
			TOL	°C	-10			
		WTOL	°C	35				
		Cold climate water outlet 35°C	General	Annual energy consumption	kWh	2,871	3,548	4,685
ηs (Seasonal space heating efficiency)	%			134	136	124	125	
Prated at -22°C	kW			4.0	5.0	6.1	8.7	
Qhe Annual energy consumption (GCV)	Gj			10.3	12.8	16.9	24.1	
Annual energy consumption	kWh			1,284	1,568	1,423	1,620	
Warm climate water outlet 35°C	General	ηs (Seasonal space heating efficiency)	%	210	215	200	205	
		Prated at 2°C	kW	5.1	6.4	5.4	6.3	
		Qhe Annual energy consumption (GCV)	Gj	4.62	5.64	5.12	5.83	
		Annual energy consumption	kWh	1,284	1,568	1,423	1,620	

2 Specifications

2

2-1 Technical Specifications				EWYQ004BVP	EWYQ005BVP	EWYQ006BVP	EWYQ008BVP	
Dimensions	Packed unit	Height	mm	880		1,138		
		Width	mm	1,166		1,276		
		Depth	mm	432		450		
	Unit	Height	mm	735		997		
		Width	mm	1,090		1,160		
		Depth	mm	350		380		
Weight	Packed unit	kg	89		121			
	Unit	kg	83		106			
Packing	Material	EPS / Carton / Wood			Carton / Wood / PE wrapping foil			
	Weight	kg	6		15			
Casing	Colour	Ivory white						
	Material	Polyester painted galvanised steel plate			Painted galvanized steel plate			
Water heat exchanger	Quantity	1						
	Type	Braze plate						
	Water flow rate	Min.	l/min	13 (6)		20 (7)		
		Cooling	Nom.	l/min	11.5 (1) / 11.5 (2)	14.1 (1) / 14.5 (2)	16.9 (1) / 17.4 (2)	22.8 (1) / 23.6 (2)
			Heating	Nom.	l/min	11.8 (3) / 11.4 (4)	14.3 (3) / 14.3 (4)	17.6 (3) / 17.5 (4)
	Water volume	l	1		2			
Insulation material	Closed cell foam elastomer							
Air heat exchanger	Type	Cross fin coil/Hi-X tubes and chromate coated waffle louvre fins			Cross fin coil/Hi-X tubes and PE coated waffle louvre fins			
	Empty tubeplate hole	-			0			
	Face area	m ²	-			0.87		
	Fin	Treatment	Anti-corrosion treatment (PE)					
		Type	WF fin					
	Fin pitch	mm	1,8		1,4			
	Length	mm	845		904			
	Passes	Quantity	-			12		
	Rows	Quantity	2					
	Stages	Quantity	32		44			
	Pump Standard	Nominal ESP unit	Cooling	kPa	73.8 (1) / 73.8 (2)	71.1 (1) / 70.6 (2)	70.9 (1) / 70.2 (2)	61.5 (1) / 59.9 (2)
Heating			kPa	73.5 (3) / 73.9 (4)	70.9 (3) / 70.9 (4)	69.9 (3) / 70.0 (4)	60.8 (3) / 58.7 (4)	
Nr of speeds		PWM controlled						
Model		Wilco Yonos Para GT15/7.5 PWM1						
Power input		W	76					
Quantity		1						
Hydraulic components	Expansion vessel	Max. water volume in the system	l	105		250		
		Max. water pressure	bar	3				
		Pre pressure	bar	1				
		Volume	l	3		7		
	Safety valve	bar	3					
	Unit water volume	l	2.0 (7)		2.8 (8)			
	Water filter	Diameter	inch	1"				
		Diameter perforations	mm	1				
Material		Copper - brass - stainless steel						
Compressor	Quantity	1						
	Type	Hermetically sealed swing compressor						
	Model	2YC45DXD#C			2YC63SXD			
	Starting method	Inverter driven						
Fan	Quantity	1						
	Type	Propeller fan						
	Air flow rate	Cooling	Nom.	m ³ /min	53		72 (1)	
		Heating	Nom.	m ³ /min	47.0		46.6 (3)	49.3 (3)
	Diameter	mm	455		510			
Discharge direction	Horizontal							
Fan motor	Drive	-			Direct drive			
	Model	-			Brushless DC motor			
	Output	W	53		200			
	Quantity	-			1			

2 Specifications

2-1 Technical Specifications					EWYQ004BVP	EWYQ005BVP	EWYQ006BVP	EWYQ008BVP	
Sound power level	Cooling	Nom.	dB(A)		63 (1)	64 (1)	69 (1)		
	Heating	Nom.	dB(A)		65 (3)				
Sound pressure level	Cooling	Nom.	dB(A)		48 (9)	49 (9)	52 (10)	53 (10)	
	Heating	Nom.	dB(A)		49 (9)		47 (10)		
	Night quiet mode	Cooling		dB(A)		44 (9)		43 (10)	
		Heating		dB(A)		46 (9)		43 (10)	
Operation range	Air side	Cooling	Max.	°CDB	43		46		
			Min.	°CDB	10				
		Heating	Max.	°CDB	25				
			Min.	°CDB	0		-15		
	Water side	Cooling	Max.	°CDB	22				
			Min.	°CDB	5				
		Heating	Max.	°CDB	55				
			Min.	°CDB	15 (8)		15 (9)		
Refrigerant	Type				R-410A				
	GWP				2,088		2,087.5		
	Circuits	Quantity			1				
	Control				Electronic expansion valve				
Refrigerant charge	Per circuit			kg	2.10		2.70		
				TCO ₂ eq	4.4		5.6		
Water circuit	Air purge valve				Yes (Manually)				
	Drain valve / fill valve				Yes				
	Flow sensor				Yes				
	flowswitch				Yes				
	Manometer				No				
	Minimum water volume in the system			l	20				
	Piping connections diameter			inch	1" MBSP				
	Shut off valve				Yes				
Refrigerant oil	Type				Daphne FVC50K				
	Charged volume			l	0.65		0.9		
Defrost method					Reversed cycle				
Defrost control					Sensor for outdoor heat exchanger temperature				
Safety devices	Item	01			High pressure (pressure switch)		High pressure switch		
		02			Fan motor thermal protection		Low pressure switch		
		03			Fuse		Fan driver overload protector		
		04			-		Fuse		
PED	Category				Category I / (10)		Category I / (11)		
Control systems	Class of temperature control				VI				
	Contribution to seasonal space heating efficiency			%	4.0				
General	Supplier/ Manufacturer details	Name and address			Daikin Industries Czech Republic s.r.o. U Nove Hospody 1/1155, 301 00		Daikin Europe N.V. - Zandvoordestraat 300, 8400 Oostende, Belgium		
		Name or trademark			Daikin Europe N.V.				
	Product description	Air-to-water heat pump			Yes				
		Brine-to-water heat pump			No				
		Heat pump combination heater			No				
		Low-temperature heat pump			No				
		Supplementary heater integrated			No				
Water-to-water heat pump			No						
LW(A) Sound power level (according to EN14825)			dB(A)	65					
Sound condition Ecodesign and energy label					Sound power in heating mode, measured according to the EN12102 under conditions of the EN14825				

2 Specifications

2

2-2 Electrical Specifications				EWYQ004BVP	EWYQ005BVP	EWYQ006BVP	EWYQ008BVP
Unit	Starting current	Max	A	15.7 (11)		19.9 (12)	
	Current	Zmax	List	-		No requirements	
	Running current	Max	A	15.7		19.9	
	Minimum Ssc value			-		Equipment complying with EN/IEC 61000-3-12 / (13) / See note 14	
	Recommended fuses			A	20		25
Power supply	Phase			1N~			
	Frequency			Hz			
	Voltage			V			
	Voltage range	Min.	%	0		-10	
Max.		%	10				
Wiring connections	For connection with control box	Quantity		8			
		Remark		2 wires: minimum cable section 0,75 mm ² / maximum length: 20 m / 2 wires: minimum cable section 0,75 mm ² / maximum length: 500 m / 4 wires: 230 V			
	Preferential kWh rate power supply	Quantity		Power: 2			
		Remark		230 V			
	For connection with user interface	Quantity		2			
		Remark		0.75 mm ² till 1.25 mm ² (max length 500m)	0.75 mm ² till 1,25 mm ² (max length 500m)	Cable section minimum 0.75mm ² , maximum length 500m	
For connection with R6T	Quantity		2				
	Remark		Minimum 0.75 mm ²				
Cable requirements	Power supply	Required number of conductors		2 + GND			
	Cooling/Heating output	Quantity of wires		2			
		Maximum running current	A	Minimum cable section 0.75 mm ²			

Notes

- (1) Cooling: entering evaporator water temp. 12°C; leaving evaporator water temp. 7°C; ambient air temp. 35°C
- (2) Cooling: entering evaporator water temp. 23°C; leaving evaporator water temp. 18°C; ambient air temp. 35°C; standard: non-Eurovent
- (3) Heating: entering condenser water temp. 40°C; leaving condenser water temp. 45°C; ambient air temp. 7°CDB, 6°CWB; standard: Eurovent
- (4) Heating: entering condenser water temp. 30°C; leaving condenser water temp. 35°C; ambient air temp. 7°CDB, 6°CWB; standard: Eurovent
- (5) All performance calculations are strictly according to Eurovent standard
- (6) Operation area is extended to lower flow rates only in case the unit operates with heat pump only. (Not in startup, no BUH operation, no defrost operation).
- (7) Including piping + PHE; excluding expansion vessel
- (8) Lower if back-up heater is installed; In case of no back-up heater, then heat pump operation starts at 10°C
- (9) The sound pressure level is measured via a microphone at a certain distance from the unit. It is a relative value depending on the distance and acoustic environment. Refer to sound spectrum drawing for more information.
- (10) Assembly ≤ category I: excluded from 2014/68/EU due to article 1, 2f
- (11) Inverter controlled compressor starting current always ≤ max. running current
- (12) For average climate and low temperature application
- (13) Ssc: Short-circuit power
- (14) European/international technical standard setting the limits for harmonic currents produced by equipment connected to public low-voltage system with input current larger than 16A and ≤ 75A per phase.

3 Electrical data

3 - 1 Electrical Data

EWYQ-BVP

* Electrical meter specification

- Pulse meter type/voltage-free contact for 5 V DC detection by PCB.
- Possible number of pulses
 - 0.1· pulse/kWh
 - 1· pulse/kWh
 - 10· pulse/kWh
 - 100· pulse/kWh
 - 1000· pulse/kWh
- Pulse duration
 - minimum On time: ·40ms·
 - Minimum OFF time: ·100ms·
- Measurement type (depending on installation)
 - Single-phase AC meter
 - Three-phase AC meter
 - Balanced loads
 - Three-phase AC meter
 - Unbalanced loads

* Electrical meter installation guideline

- the installer to cover
- Required number of electrical meters

Outdoor unit type		*EW(Y/A)Q(4/5/6/8)*			
Indoor unit type		Optional	*KMBUHCA(3V3/9W1)		
	Backup heater type		3V / 9W	9W	
	Backup heater power supply		1~ 230V	3~ 400V	
	Backup heater configuration		3 / 6 3 / 6 kW	6 / 9 kW	
Normal kWh rate power supply					
Electrical meter type	1~	1	1	1	-
	3~ balanced	-	-	1	-
	3~ unbalanced	-	-	-	1
Preferential kWh rate power supply					
Electrical meter type	1~	2	2	1	
	3~ balanced	-	-	-	
	3~ unbalanced	-	-	1	

4D109569

3 Electrical data

3 - 1 Electrical Data

3

EWYQ-BVP

Specifications Starting current

Inverter-controlled compressor starting current always \leq max. running current.

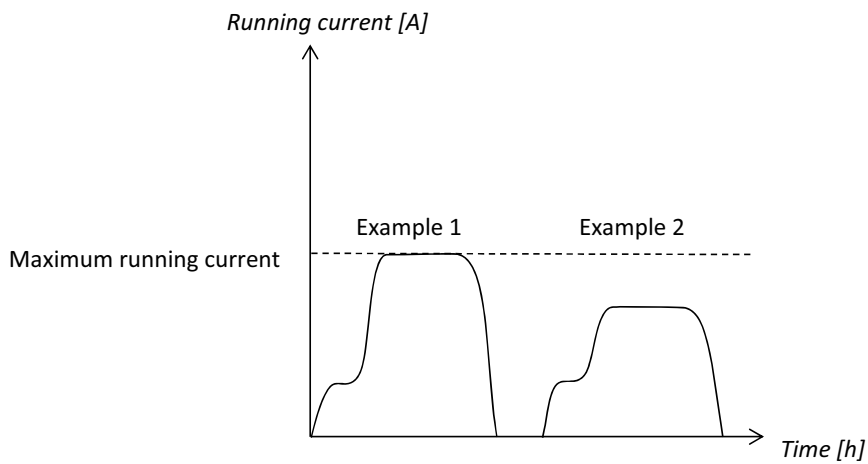

Standard On/OFF compressor starting current \gg max. running current

Not applicable for EW(A/Y)Q*BAVP* models.

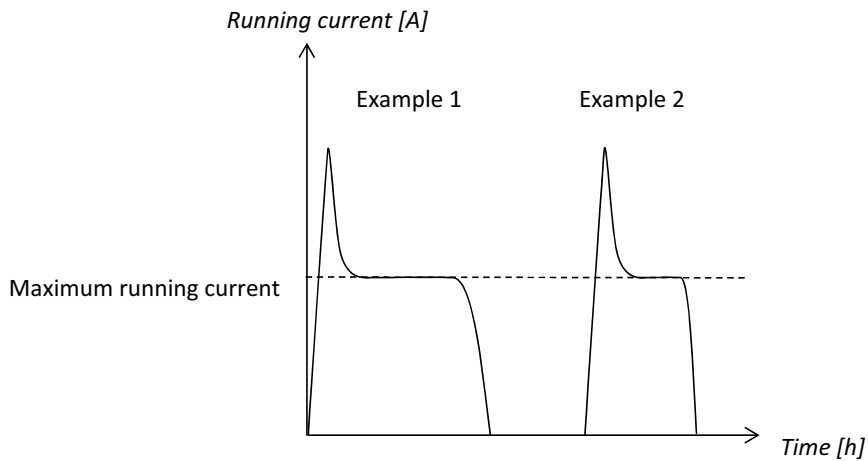

4D109570

3 Electrical data

3 - 1 Electrical Data

EWYQ-BVP

Electrical specifications Backup heater						
Backup heater	Type			3V	9W	
	Capacity setting		kW	3	3	6
	Capacity stage			1	1	2
	Capacity stage 1		kW	3		
	Capacity stage 2		kW	-	-	9
	Minimum time delay between stages			Note 4	Note 5	
	Power supply (1)	Phase			1~	
	Frequency		Hz	50		
	Voltage		V	230		
	Nominal running current		A	13	26	8,7
Current	Zmax (backup heater) (2)		Ω	-		
			Complex	-		
	Minimum Ssc value		kVA	-	(3)	-
Notes	(1)	The above-mentioned power supply of the hydrobox is for the backup heater only.				
	(2)	In accordance with EN/IEC 61000-3-11, it may be necessary to consult the distribution network operator to ensure that the equipment is connected only to a supply with $Z_{sys} \leq Z_{max}$.				
	(3)	The equipment complies with EN/IEC 61000-3-12.				
	EN/IEC 61000-3-11	European/International Technical Standard setting the limits for voltage changes, voltage fluctuations and flicker in public low-voltage supply systems for equipment with rated current ≤ 75 A.				
	EN/IEC 61000-3-12	European/International Technical Standard setting the limits for harmonic currents produced by equipment connected to public low-voltage systems with input current > 16 A and ≤ 75 A per phase.				
Zsys	System impedance					

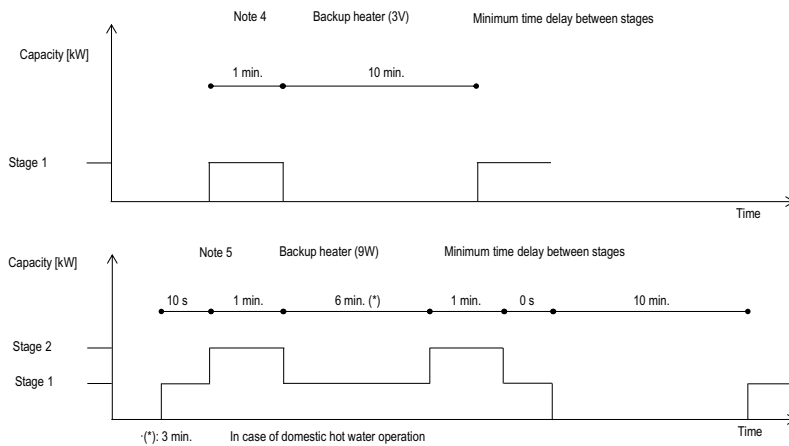

4D109574

4 Options

4 - 1 Options

4

EWYQ004BAVP EWYQ005BAVP

Kit availability for ·EW(A/Y)Q*BAVP*·

Reference	Description	Notes	EW(A/Y)Q	004BAVP*	006BAVP*
			EW(A/Y)Q	005BAVP*	008BAVP*
EKCB07CAV3	Control box			o	o
EKRUMCL1	Remote user interface			o	o
EKRSCA1	Remote sensor for outdoor	(8)		o	o
EKPCCAB*	PC cable kit	(9)		o	o
EKBPH140L7*	Bottom plate heater	(10)			o

Kit availability for ·EKCB*C* (1)·

Reference	Description	Notes	#
EK2CB07CAV3	Option box	(2)	o
EKMBUHC*3V3	Backup heater kit	(4) (6) (5)	o
EKMBUHC*9W1	Backup heater kit	(4) (6) (5)	o
EKRTR1	Wireless room thermostat	(receiver included)	o
EKRTEETS	External temperature sensor option kit	(3)	o

Kit availability for ·EK2CB*C* (2)·

Reference	Description	Notes	#
KRCS01-1	Remote sensor for indoor	(8)	o

Factory-mounted optional equipment for ·KMBUHC* (5)·

Description	#	
	EKMBUH*3V3	EKMBUH*9W1 (7)
Backup heater ·3kW 1N~230 V·	o	o
Backup heater ·6kW 1N~230 V·		o
Backup heater ·6kW 3N~400 V·		o
Backup heater ·9kW 3N~400 V·		o

Notes

- (1) To be able to use these options, it is required that control box ·EKCB*C*· is part of the system.
 - (a) Backup heater
 - (b) External room thermostat/heat pump convector
 - (c) Option box
 - (d) Electricity meter
 - (e) Power limitation digital inputs
- (2) To be able to use these options, it is required that option box ·EK2CB*C*· is part of the system.
 - (a) Control external heat source (bivalent operation).
 - (b) Output remote ON/OFF signal space heating/cooling
 - (c) Remote alarm output
 - (d) External indoor thermistor
- (3) ·EKRTETS· can only be used in combination with ·EKRTR1·.
- (4) Only ·1· of these ·· options can be installed per indoor unit.
- (5) Only for reversible models
- (6) If condensation is expected, the installation of valve kit ·EKMBHBP1· is required.
- (7) Unified model, the actual backup heater capacity depends on the actual internal upwiring.
- (8) Only 1 sensor connectable: indoor or outdoor
- (9) Data cable for connection with PC.
- (10) In case of high humidity conditions (relative humidity >92%; outdoor ambient temperatures <-5°C), an optional bottom plate heater is required. This to avoid freeze-up of the outdoor unit.

Kit availability for ·EKMBUHC*·

Reference	Description	Notes	#
EKMBHBP1	Valve kit	(6) (5)	o

Remark

Other combinations than mentioned in this combination table are prohibited.

3D109244B

5 Capacity tables

5 - 1 Cooling Capacity Tables

EWYQ004-005BVP

Nominal cooling capacity

T _{amb} [°C]		20		25		30		35		40		43	
LWE [°C]		CC [kW]	PI [kW]	CC [kW]	PI [kW]	CC [kW]	PI [kW]	CC [kW]	PI [kW]	CC [kW]	PI [kW]	CC [kW]	PI [kW]
EW(A/Y)Q004*	7	5,16	0,91	4,82	1,02	4,41	1,15	4,00	1,27	3,35	1,32	2,96	1,35
	10	5,40	0,89	5,30	1,01	4,89	1,15	4,48	1,29	3,71	1,31	3,24	1,32
	13	5,64	0,87	5,78	1,01	5,37	1,15	4,96	1,30	4,06	1,30	3,53	1,30
	15	5,80	0,86	6,09	1,00	5,69	1,16	5,28	1,31	4,30	1,29	3,71	1,28
	18	6,04	0,84	6,57	1,00	6,16	1,16	5,76	1,33	4,66	1,28	4,00	1,26
	22	6,35	0,82	7,21	0,99	6,80	1,17	6,39	1,35	5,13	1,27	4,38	1,23
EW(A/Y)Q005*	7	5,84	1,14	5,60	1,29	5,26	1,45	4,93	1,61	3,70	1,45	2,96	1,35
	10	6,20	1,15	6,17	1,30	5,78	1,46	5,38	1,63	4,04	1,44	3,24	1,32
	13	6,55	1,16	6,74	1,31	6,29	1,48	5,83	1,65	4,39	1,43	3,53	1,30
	15	6,79	1,16	7,13	1,32	6,63	1,49	6,13	1,66	4,62	1,42	3,71	1,28
	18	7,14	1,17	7,70	1,33	7,14	1,50	6,58	1,68	4,97	1,42	4,00	1,26
	22	7,62	1,18	8,46	1,35	7,82	1,52	7,18	1,70	5,43	1,41	4,38	1,23

Symbols

- CC Cooling capacity at nominal operating frequency, measured according to EN 14511.
- HC Heating capacity at maximum operating frequency, measured according to EN 14511
- PI The power input is the total input according to EN 14511.
- LWE Leaving water evaporator temperature [°C]
- LWC Leaving water condenser temperature [°C]
- Tamb Ambient temperature; RH (heating) = 85%

Conditions

Cooling capacity

Capacity according to standard EN 14511 and valid for chilled water range ΔT = 3~8°C.
 Capacity values may not be extrapolated below 7°C leaving water temperature.

Heating capacity

Capacity according to standard EN 14511 and valid for heated water range ΔT = 3~8°C.

Power input

Power input is the total input of indoor and outdoor units, including the circulation pump; according to EN 14511.

Notes

- The capacity and the power input are valid for V3 models at 230 V.
- The capacity and the power input are at maximum operation.

3D109494

5 Capacity tables

5 - 1 Cooling Capacity Tables

5

EWYQ006-008BVP

Nominal cooling capacity

	T _{amb} [°C]	20		25		30		35		40		43		46	
	LWE [°C]	CC [kW]	PI [kW]	CC [kW]	PI [kW]	CC [kW]	PI [kW]	CC [kW]	PI [kW]	CC [kW]	PI [kW]	CC [kW]	PI [kW]	CC [kW]	PI [kW]
EW(A)YQ006*	7	8,22	1,35	7,43	1,51	6,64	1,68	5,85	1,84	4,74	2,00	4,07	2,09	3,40	2,18
	10	8,85	1,24	8,14	1,45	7,43	1,66	6,72	1,86	5,66	2,04	5,02	2,14	4,39	2,25
	13	9,49	1,14	8,85	1,39	8,22	1,64	7,59	1,88	6,58	2,08	5,97	2,19	5,37	2,31
	15	9,91	1,08	9,33	1,35	8,75	1,62	8,17	1,90	7,19	2,10	6,61	2,23	6,02	2,35
	18	10,54	0,98	10,04	1,29	9,54	1,61	9,04	1,92	8,12	2,15	7,56	2,28	7,01	2,42
	22	11,38	0,84	10,99	1,21	10,59	1,58	10,20	1,95	9,34	2,20	8,83	2,35	8,32	2,50
EW(A)YQ008*	7	9,42	1,86	8,93	2,08	8,45	2,30	7,96	2,52	6,44	2,71	5,53	2,82	4,62	2,93
	10	9,46	1,51	9,23	1,86	9,00	2,22	8,77	2,58	7,24	2,71	6,33	2,79	5,41	2,87
	13	9,51	1,16	9,54	1,65	9,56	2,14	9,58	2,63	8,05	2,72	7,13	2,77	6,21	2,81
	15	9,55	0,92	9,74	1,51	9,93	2,09	10,12	2,67	8,58	2,72	7,66	2,75	6,74	2,78
	18	9,60	0,57	10,04	1,29	10,49	2,01	10,93	2,73	9,39	2,72	8,46	2,72	7,53	2,72
	22	9,66	0,10	10,44	1,00	11,23	1,90	12,01	2,81	10,46	2,73	9,53	2,68	8,59	2,64

Symbols

- CC Cooling capacity at nominal operating frequency, measured according to EN 14511.
- HC Heating capacity at maximum operating frequency, measured according to EN 14511
- PI The power input is the total input according to EN 14511:2013
- LWE Leaving water evaporator temperature [°C]
- LWC Leaving water condensor temperature [°C]
- Tamb Ambient temperature; RH (heating) = 85%

Conditions

Cooling capacity

Capacity according to standard EN 14511 and valid for chilled water range $\Delta T = 3\sim 8^{\circ}\text{C}$.
Capacity values may not be extrapolated below 7°C leaving water temperature.

Heating capacity

Capacity according to standard EN 14511 and valid for heated water range $\Delta T = 3\sim 8^{\circ}\text{C}$.

Power input

Power input is the total input of indoor and outdoor units, including the circulation pump; according to EN 14511.

Notes

The capacity and the power input are valid for V3 models at 230 V.

The capacity and the power input are at maximum operation.

3D109724

5 Capacity tables

5 - 2 Heating Capacity Tables

EWYQ004-005BVP
Reversible model

Maximum heating capacity - peak values

LWC [°C]		30		35		40		45		50		55	
T _{amb} [°C]		HC [kW]	PI [kW]	HC [kW]	PI [kW]	HC [kW]	PI [kW]	HC [kW]	PI [kW]	HC [kW]	PI [kW]	HC [kW]	PI [kW]
EWYQ004*	-20	2,81	1,78	2,76	1,93	2,72	2,06						
	-15	3,65	1,72	3,57	1,86	3,49	1,99	3,38	2,09	3,17	2,16		
	-7	5,38	1,63	5,19	1,77	4,95	1,89	4,84	1,99	4,57	2,05	4,18	2,11
	-2	5,99	1,59	5,83	1,72	5,55	1,86	5,36	1,96	5,04	2,03	4,57	2,11
	2	6,37	1,54	6,16	1,67	5,88	1,81	5,68	1,93	5,48	2,00	4,56	1,99
	7	7,17	1,49	7,02	1,61	6,83	1,75	6,60	1,89	6,20	1,97	4,16	1,55
	12	7,82	1,44	7,58	1,55	7,23	1,66	6,88	1,81	6,51	1,89	4,16	1,38
	15	8,51	1,42	8,23	1,52	7,87	1,65	7,51	1,80	7,07	1,89	4,16	1,29
20	9,81	1,38	9,43	1,47	9,08	1,62	8,68	1,78	8,15	1,89	4,16	1,16	
EWYQ005*	-20	3,29	2,12	3,22	2,28	3,19	2,44						
	-15	4,26	2,07	4,17	2,23	4,10	2,38	3,97	2,48	3,74	2,54		
	-7	6,28	2,01	6,07	2,17	5,86	2,33	5,74	2,43	5,46	2,49	5,02	2,54
	-2	6,99	1,94	6,81	2,10	6,52	2,26	6,33	2,39	5,99	2,46	4,87	2,31
	2	7,48	1,90	7,26	2,05	6,96	2,22	6,76	2,36	6,57	2,45	4,56	1,99
	7	8,48	1,84	8,35	2,00	8,17	2,17	7,95	2,35	7,53	2,44	4,16	1,55
	12	9,20	1,82	8,97	1,96	8,73	2,13	8,37	2,32	8,01	2,43	4,16	1,38
	15	10,03	1,79	9,77	1,92	9,46	2,10	9,10	2,29	8,65	2,41	4,16	1,29
20	11,51	1,76	11,21	1,88	10,85	2,07	10,44	2,26	9,89	2,40	4,16	1,16	

Maximum heating capacity - integrated value

LWC [°C]		30		35		40		45		50		55	
T _{amb} [°C]		HC [kW]	PI [kW]	HC [kW]	PI [kW]	HC [kW]	PI [kW]	HC [kW]	PI [kW]	HC [kW]	PI [kW]	HC [kW]	PI [kW]
EWYQ004*	-20	2,72	1,60	2,69	1,80	2,52	2,01						
	-15	3,57	1,57	3,47	1,74	3,24	1,92	3,09	2,05	3,03	2,12		
	-7	4,73	1,49	4,61	1,65	4,52	1,81	4,43	1,93	4,22	2,00	3,85	2,07
	-2	5,27	1,46	5,20	1,60	5,14	1,75	4,82	1,88	4,70	1,96	4,28	2,04
	2	5,60	1,44	5,44	1,55	5,23	1,69	5,09	1,81	4,97	1,90	4,19	1,92
	7	7,17	1,49	7,02	1,61	6,83	1,75	6,60	1,89	6,20	1,97	4,16	1,55
	12	7,82	1,44	7,58	1,55	7,23	1,66	6,88	1,81	6,51	1,89	4,16	1,38
	15	8,51	1,42	8,23	1,52	7,87	1,65	7,51	1,80	7,07	1,89	4,16	1,29
20	9,81	1,38	9,43	1,47	9,08	1,62	8,68	1,78	8,15	1,89	4,16	1,16	
EWYQ005*	-20	3,19	1,91	3,14	2,14	2,96	2,37						
	-15	4,17	1,88	4,05	2,08	3,80	2,30	3,64	2,43	3,57	2,49		
	-7	5,53	1,83	5,39	2,03	5,35	2,22	5,26	2,36	5,04	2,43	4,63	2,48
	-2	6,15	1,79	6,08	1,96	6,04	2,14	5,69	2,28	5,58	2,37	4,66	2,21
	2	6,58	1,76	6,40	1,91	6,19	2,08	6,07	2,22	5,97	2,33	4,19	1,92
	7	8,48	1,84	8,35	2,00	8,17	2,17	7,95	2,35	7,53	2,44	4,16	1,55
	12	9,20	1,82	8,97	1,96	8,73	2,13	8,37	2,32	8,01	2,43	4,16	1,38
	15	10,03	1,79	9,77	1,92	9,46	2,10	9,10	2,29	8,65	2,41	4,16	1,29
20	11,51	1,76	11,21	1,88	10,85	2,07	10,44	2,26	9,89	2,40	4,16	1,16	

- CC Cooling capacity at nominal operating frequency, measured according to -EN 14511-
- HC Heating capacity at maximum operating frequency, measured according to EN 14511
- PI The power input is the total input according to -EN 14511-
- LWE Leaving water evaporator temperature [°C]
- LWC Leaving water condensor temperature [°C]
- Tamb Ambient temperature; RH (heating) = 85%

Conditions

Cooling capacity

Capacity according to standard EN 14511 and valid for chilled water range $\Delta T = 3\text{~}8^{\circ}\text{C}$.
Capacity values may not be extrapolated below 7°C leaving water temperature.

Heating capacity

Capacity according to standard EN 14511 and valid for heated water range $\Delta T = 3\text{~}8^{\circ}\text{C}$.

Power input

Power input is the total input of indoor and outdoor units, including the circulation pump; according to EN 14511.

Notes

The capacity and the power input are valid for V3 models at 230 V.
The capacity and the power input are at maximum operation.

3D109494

5 Capacity tables

5 - 2 Heating Capacity Tables

5

EWYQ006-008BVP													
Reversible model													
Maximum heating capacity - peak values													
	LWC [°C]	30		35		40		45		50		55	
	T _{amb} [°C]	HC [kW]	PI [kW]	HC [kW]	PI [kW]	HC [kW]	PI [kW]	HC [kW]	PI [kW]	HC [kW]	PI [kW]	HC [kW]	PI [kW]
EWYQ006*	-15	4,59	2,03	4,37	2,18	4,14	2,34	-	-	-	-	-	-
	-7	6,85	2,07	6,63	2,26	6,40	2,45	6,18	2,64	5,50	2,82	4,83	3,00
	-2	7,20	1,80	6,92	1,98	6,64	2,16	6,36	2,34	6,00	2,53	5,63	2,73
	2	8,17	1,84	7,86	2,02	7,54	2,21	7,23	2,40	6,96	2,62	6,69	2,84
	7	7,75	1,38	7,39	1,54	7,02	1,71	6,66	1,87	6,46	2,04	6,25	2,22
	12	8,18	1,34	7,84	1,50	7,49	1,66	7,14	1,82	6,89	2,00	6,63	2,18
	15	7,73	1,16	7,40	1,30	7,07	1,45	6,74	1,60	6,43	1,77	6,13	1,95
20	8,59	1,16	8,23	1,32	7,86	1,47	7,50	1,62	7,17	1,81	6,84	1,99	
EWYQ008*	-15	5,84	2,92	5,14	2,93	4,45	2,94	-	-	-	-	-	-
	-7	8,91	2,84	8,28	3,05	7,66	3,26	7,04	3,48	6,17	3,50	5,30	3,52
	-2	9,34	2,49	8,87	2,74	8,40	2,99	7,93	3,24	7,06	3,37	6,20	3,51
	2	10,61	2,58	10,05	2,83	9,49	3,08	8,93	3,33	7,93	3,42	6,92	3,50
	7	10,32	2,05	10,01	2,29	9,70	2,52	9,39	2,76	8,90	3,04	8,42	3,31
	12	10,67	1,87	10,29	2,09	9,92	2,31	9,55	2,53	9,27	2,80	8,99	3,07
	15	9,30	1,43	8,90	1,61	8,50	1,78	8,10	1,96	7,90	2,15	7,69	2,34
20	10,31	1,45	9,87	1,63	9,43	1,81	9,00	1,99	8,81	2,19	8,62	2,39	
Maximum heating capacity - integrated value													
	LWC [°C]	30		35		40		45		50		55	
	T _{amb} [°C]	HC [kW]	PI [kW]	HC [kW]	PI [kW]	HC [kW]	PI [kW]	HC [kW]	PI [kW]	HC [kW]	PI [kW]	HC [kW]	PI [kW]
EWYQ006*	-15	4,03	1,90	3,82	2,04	3,62	2,18	-	-	-	-	-	-
	-7	5,93	1,86	5,71	2,05	5,50	2,23	5,30	2,42	4,75	2,58	4,20	2,73
	-2	5,43	1,47	5,30	1,65	5,15	1,83	5,01	2,01	4,93	2,25	4,83	2,49
	2	5,45	1,39	5,41	1,57	5,35	1,76	5,28	1,96	5,49	2,27	5,67	2,59
	7	7,75	1,38	7,39	1,54	7,02	1,71	6,66	1,87	6,46	2,04	6,25	2,22
	12	8,18	1,34	7,84	1,50	7,49	1,66	7,14	1,82	6,89	2,00	6,63	2,18
	15	7,73	1,16	7,40	1,30	7,07	1,45	6,74	1,60	6,43	1,77	6,13	1,95
20	8,59	1,16	8,23	1,32	7,86	1,47	7,50	1,62	7,17	1,81	6,84	1,99	
EWYQ008*	-15	5,20	2,72	4,54	2,73	3,89	2,74	-	-	-	-	-	-
	-7	7,01	2,35	6,60	2,56	6,18	2,79	5,74	3,02	5,18	3,10	4,58	3,19
	-2	6,36	1,86	6,24	2,10	6,09	2,34	5,92	2,59	5,61	2,82	5,21	3,07
	2	6,32	1,76	6,31	1,99	6,26	2,24	6,18	2,49	6,00	2,73	5,68	2,97
	7	10,32	2,05	10,01	2,29	9,70	2,52	9,39	2,76	8,90	3,04	8,42	3,31
	12	10,67	1,87	10,29	2,09	9,92	2,31	9,55	2,53	9,27	2,80	8,99	3,07
	15	9,30	1,43	8,90	1,61	8,50	1,78	8,10	1,96	7,90	2,15	7,69	2,34
20	10,31	1,45	9,87	1,63	9,43	1,81	9,00	1,99	8,81	2,19	8,62	2,39	
CC	Cooling capacity at nominal operating frequency, measured according to EN 14511.												
HC	Heating capacity at maximum operating frequency, measured according to EN 14511												
PI	The power input is the total input according to EN 14511:2013												
LWE	Leaving water evaporator temperature [°C]												
LWC	Leaving water condenser temperature [°C]												
Tamb	Ambient temperature; RH (heating) = 85%												
Conditions													
<u>Cooling capacity</u>													
Capacity according to standard EN 14511 and valid for chilled water range ΔT = 3~8°C.													
Capacity values may not be extrapolated below 7°C leaving water temperature.													
<u>Heating capacity</u>													
Capacity according to standard EN 14511 and valid for heated water range ΔT = 3~8°C.													
<u>Power input</u>													
Power input is the total input of indoor and outdoor units, including the circulation pump; according to EN 14511.													
Notes													
The capacity and the power input are valid for V3 models at 230 V.													
The capacity and the power input are at maximum operation.													

3D109724

6 Dimensional drawings

6 - 1 Dimensional Drawings

EWYQ004-005BVP

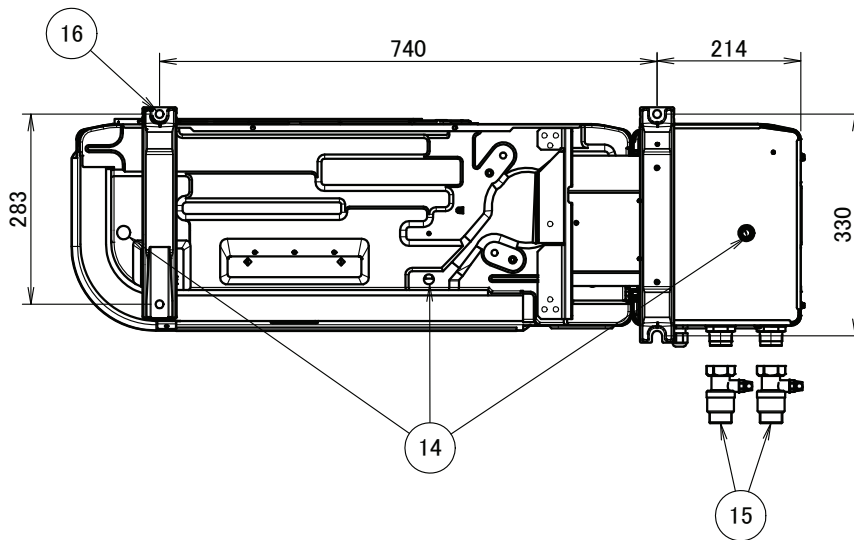
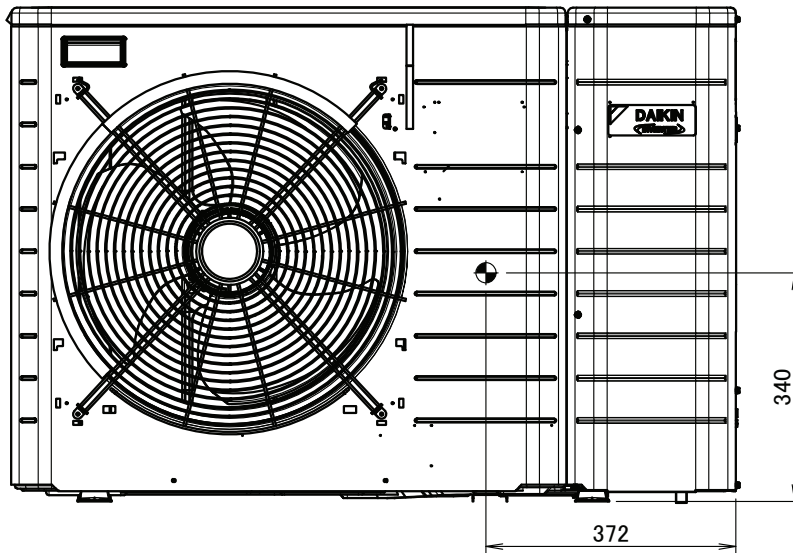
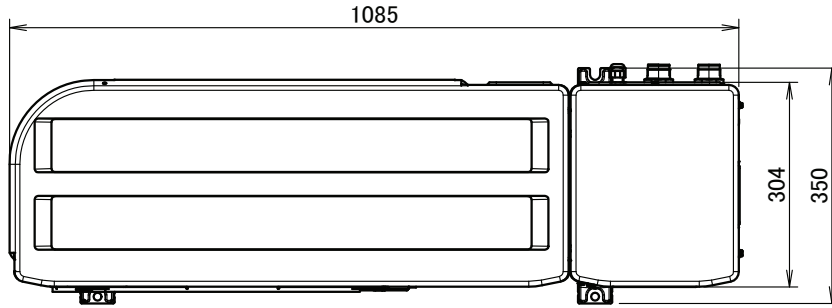

6 Dimensional drawings

6 - 1 Dimensional Drawings

EWYQ004-005BVP

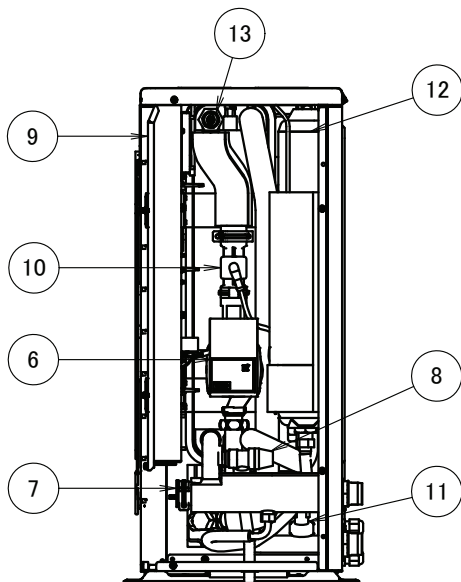
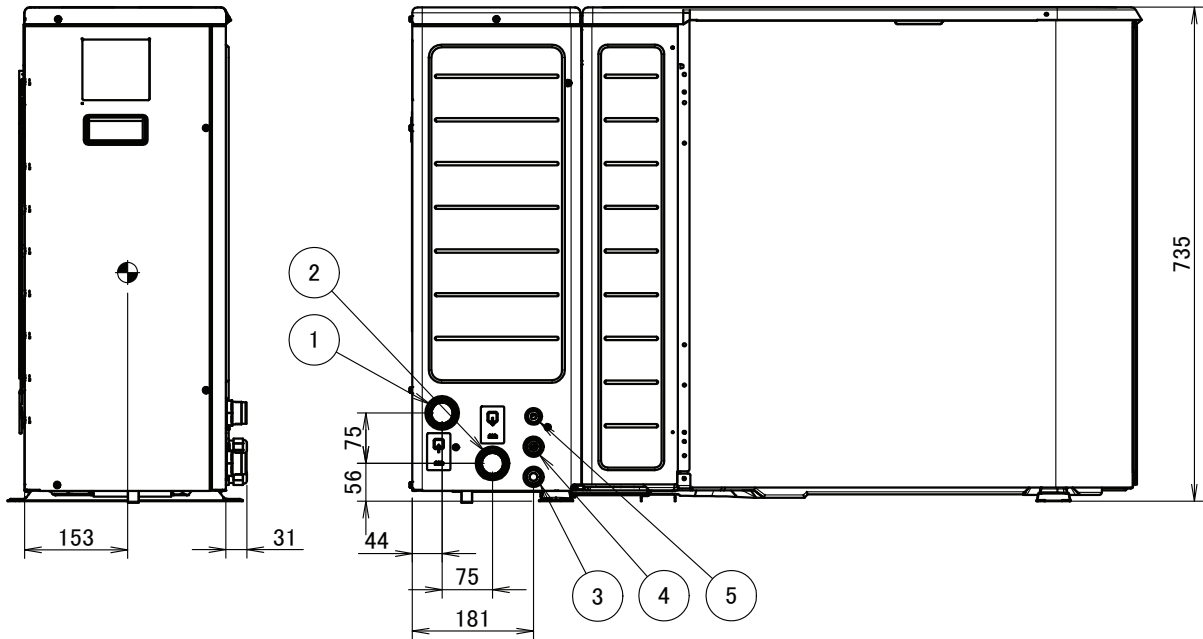

- ① Water in connection 1" M
- ② Water out connection 1" M
- ③ Wiring intake (power supply)
- ④ Wiring intake (high voltage wiring)
- ⑤ Wiring intake (low voltage wiring)
- ⑥ Pump
- ⑦ Water filter
- ⑧ Safety valve
- ⑨ Switch box
- ⑩ Flow sensor
- ⑪ Flow switch
- ⑫ Expansion vessel
- ⑬ Air purge valve
- ⑭ Drain outlet
- ⑮ Shut-off valve with drain / fill valve 1" (included accessory) 4 holes for anchor
- ⑯ Bolts

6 Dimensional drawings

6 - 1 Dimensional Drawings

EWYQ006-008BVP

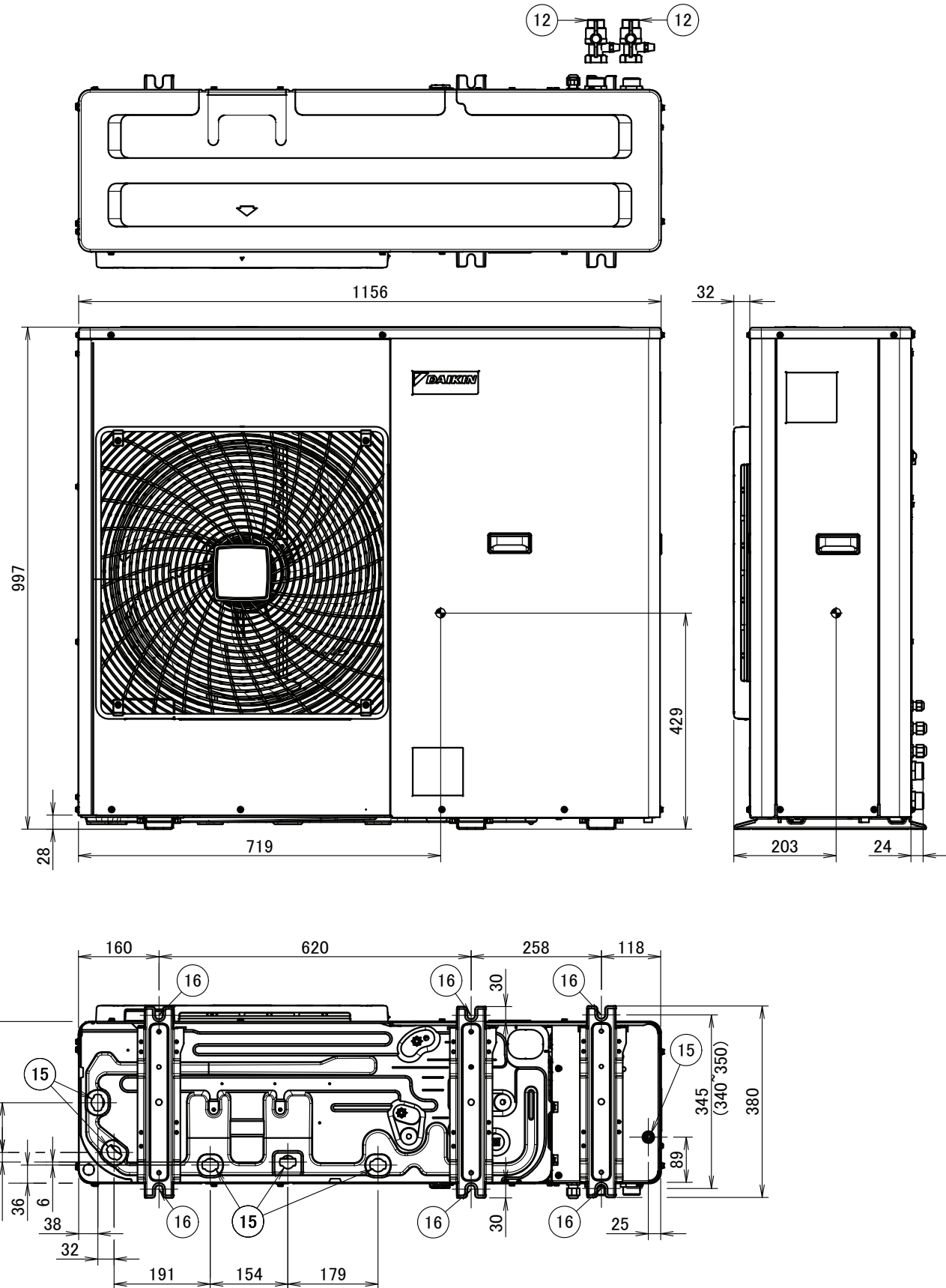

6 Dimensional drawings

6 - 1 Dimensional Drawings

EWYQ006-008BVP

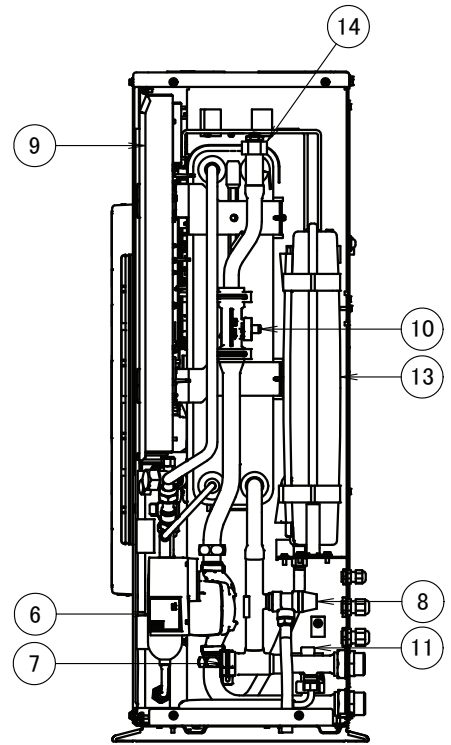
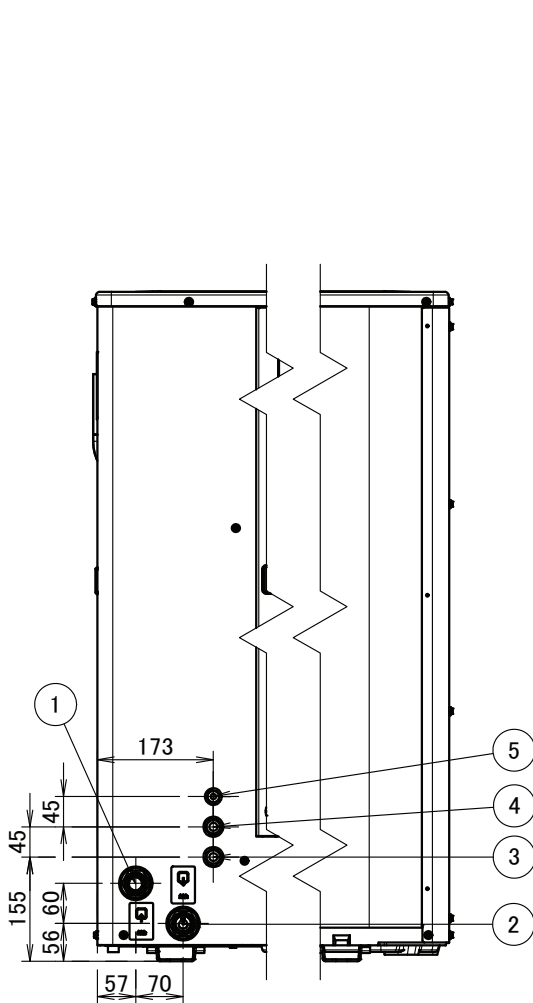

- ① Water in connection 1" M
- ② Water out connection 1" M
- ③ Wiring intake (power supply)
- ④ Wiring intake (high voltage wiring)
- ⑤ Wiring intake (low voltage wiring)
- ⑥ Pump
- ⑦ Water filter
- ⑧ Safety valve
- ⑨ Switch box
- ⑩ Flow sensor
- ⑪ Flow switch
- ⑫ Shut-off valve with drain / fill valve 1" (included accessory)
- ⑬ Expansion vessel
- ⑭ Air purge valve
- ⑮ Drain outlet
- ⑯ 6 holes for anchor bolts

7 Piping diagrams

7 - 1 Piping Diagrams

EWYQ004-005BVP

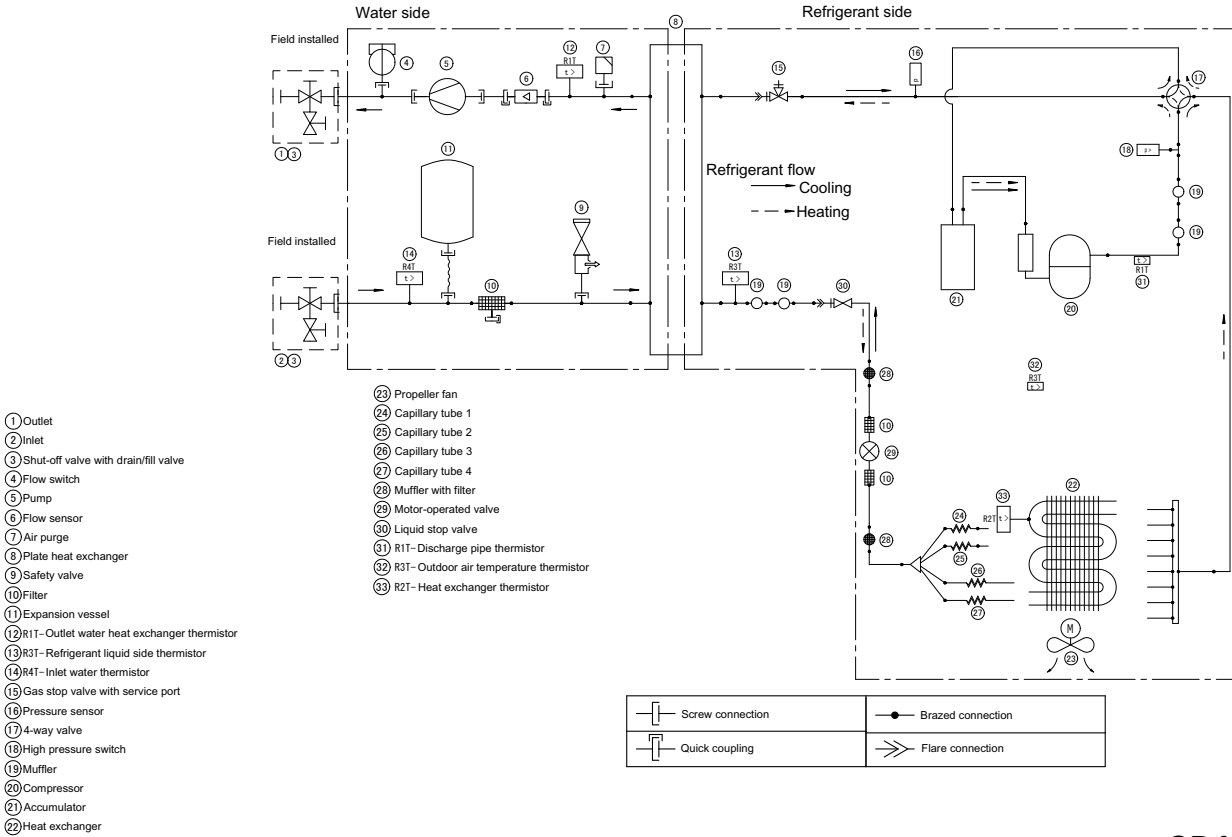

3D109206

EWYQ006-008BVP

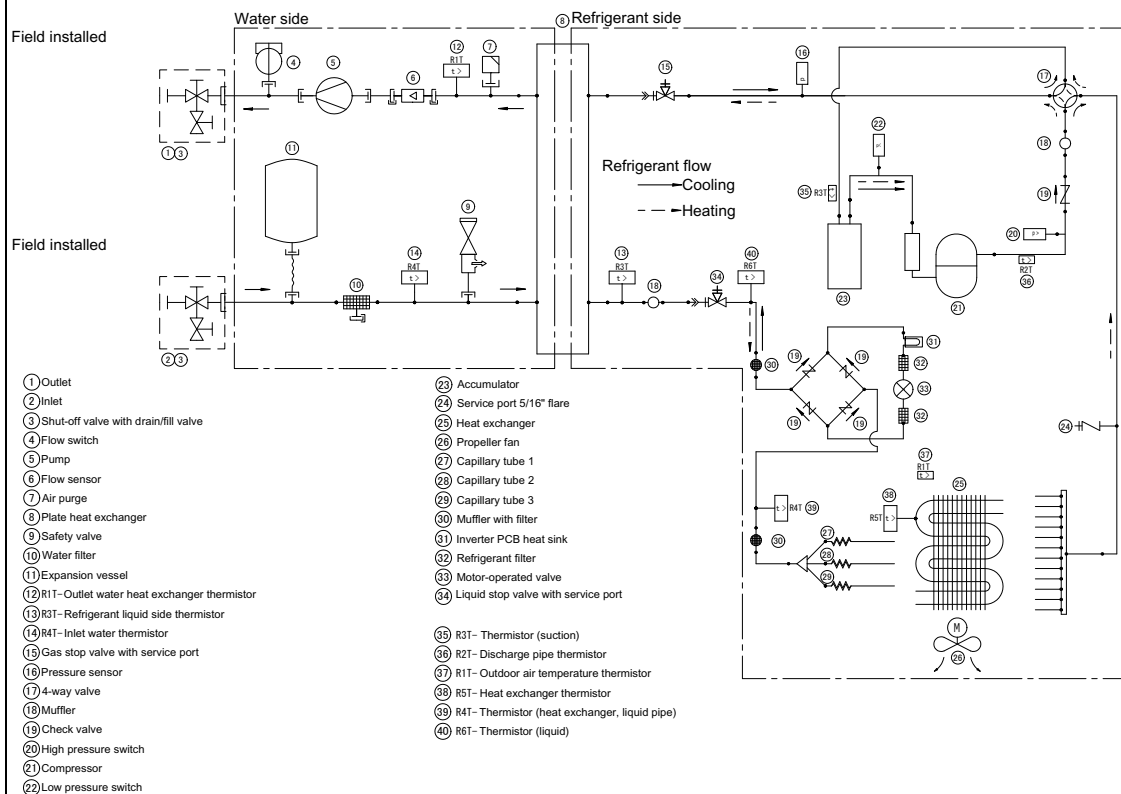

3D109731

8 Wiring diagrams

8 - 1 Wiring Diagrams - Single Phase

8

EWYQ004-005BAVP

NOTES to go through before starting the unit

- X1M : Main terminal
- Earth wiring
- 15 : Wire number 15
- Field supply
- ① : Several wiring possibilities
- Option
- Wiring depending on model
- switch box
- PCB

- User installed options:
- Remote user interface
 - Ext. outdoor thermistor
 - Control box
 - BUH option
 - BUH configuration (only for *9W)
 - 6V3 (1N~, 230V, 6kW)
 - 6WN (3N~, 400V, 6kW)
 - 9WN (3N~, 400V, 9kW)
 - Main LWT:
 - ON/OFF thermostat (wired)
 - ON/OFF thermostat (wireless)
 - Ext. thermistor
 - Option box
 - External indoor ambient thermistor

POSITION IN SWITCH BOX

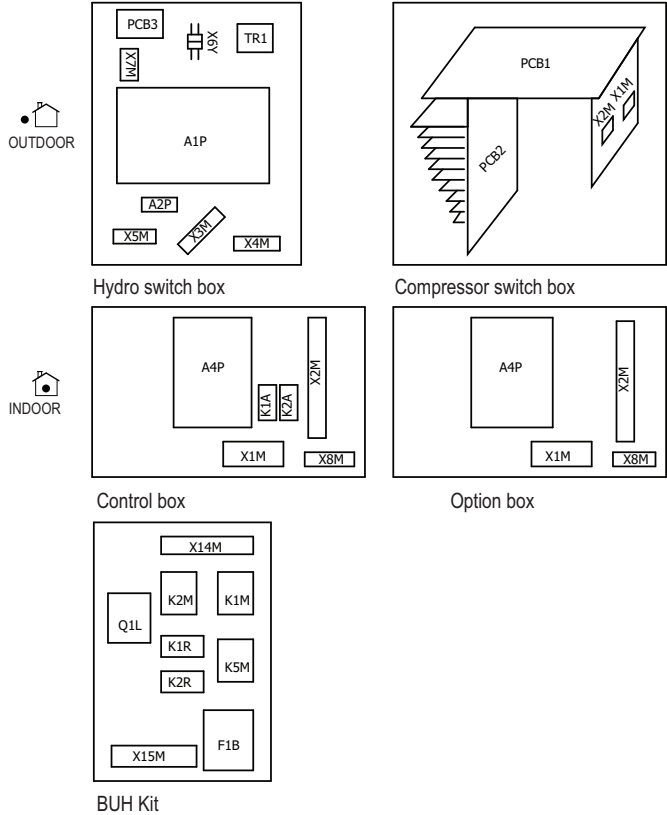

4D108719A

EWYQ004-005BAVP

LEGEND

Part n°	Description	Part n°	Description	Part n°	Description
A1P	main PCB	K1R	* relay backup heater (step 1)	R3T (A1P)	refrigerant liquid side thermistor
A2P	current loop PCB	K2A	relay for cooling	R3T (PCB1)	thermistor (air)
A3P	* ON/OFF thermostat (PC=power circuit)	K2M	* contactor BUH (step 2)	R4T (A1P)	inlet water thermistor
A4P	* extension PCB (control, optional)	K2R	* relay backup heater (step 2)	R6T (A1P)	* ext. outdoor ambient thermistor
A5P	user interface PCB	K5M	* safety contactor BUH (only *9W)	R6T (A4P)	* ext. indoor ambient thermistor
A7P	* receiver PCB (wireless On/OFF thermostat)	K*R (A1P)	relay on PCB	S1L	flow switch
B1L	flow sensor	LED 1~4 (PCB3)	indication lamps	S1NPH	pressure sensor
C110~C112 (PCB2)	capacitor	LED A~B (PCB2-3)	pilot lamp	S1PH	pressure switch (high)
DB1~401 (PCB1-2)	rectifier bridge	M1C	compressor motor	S1S	# preferential kWh rate PS contact
DS1(A4P)	* dipswitch	M1F	fan motor	S1~4P	# digital power limitation input 1~4
E1H	BUH element (1 kW)	M1P	main supply pump	S2~S503 (PCB1-2-3)	connector
E2H	BUH element (2 kW)	M2S	# Shut-OFF valve	S5P-S6P	# electrical meters
E3H	BUH element	M4S	* Valve Kit	SA1 (PCB1)	surge arrester
E11H	flextube heater (18W)	MRM*, MR30, MR4, MR306~307 (PCB1-2)	magnetic relay	SW1, SW3 (PCB3)	push buttons
E12H	expansion vessel heater (50W)	PC (A7P)	Power Circuit	SW2, SW5 (PCB3)	dip switches
E13H	PHE heater (33W)	PCB1	main PCB	TR1	power supply transformer
E14H	internal pipe heater 1 (50W)	PCB2	inverter PCB	V2, V3, V401 (PCB1)	varistor
E15H	internal pipe heater 2 (50W)	PCB3	service PCB	X*M	terminal strip
F1B	* overcurrent fuse BUH	Q1L	* thermal protector backup heater	Y1E	electronic expansion valve coil
F1T, F2T	* thermal fuse backup heater	Q1L (PCB1)	overload protector	Y1R	reversing solenoid valve coil
F1U	fuse T 5 A 500 V	Q*DI	# earth leakage circuit breaker	Z1C~Z4C	ferrite core
F1U (A4P)	fuse T 5 A 500 V BUH option	R1H (A3P)	* humidity sensor	MR30_A-B, DP1~2, E1~2, DC_P*, DC_N*	connector
F1U (A4P)	fuse T 2 A 250 V	R1T (A1P)	outlet water heat exchanger thermistor	HN402, HL402, HL1~2, HN1~2 U, V, W, X*A, X*B, X*Y	
F2U (A4P)	fuse T 2 A 250 V for 3 way valve	R1T (A3P)	* ambient sensor ON/OFF thermostat		
FU1 (A1P)	fuse T 5 A 250 V	R1T (A5P)	ambient sensor user interface		
FU1 (PCB1)	fuse T 3,15 A H 250 V	R1T (PCB1)	thermistor (discharge)		
FU2 (PCB2)	fuse T 3,15 A H 250 V	R2T	* outlet backup heater thermistor		
FU3 (PCB1)	fuse 30 A 250 V	R2T (A3P)	* external sensor (floor or ambient)		
IPM1 (PCB2)	intelligent power module	R2T (PCB1)	thermistor (heat exchange)		
K1A	relay for heating				
K1M	* contactor BUH (step 1)				

* : optional
: field supply

4D108719A

8 Wiring diagrams

8 - 1 Wiring Diagrams - Single Phase

8

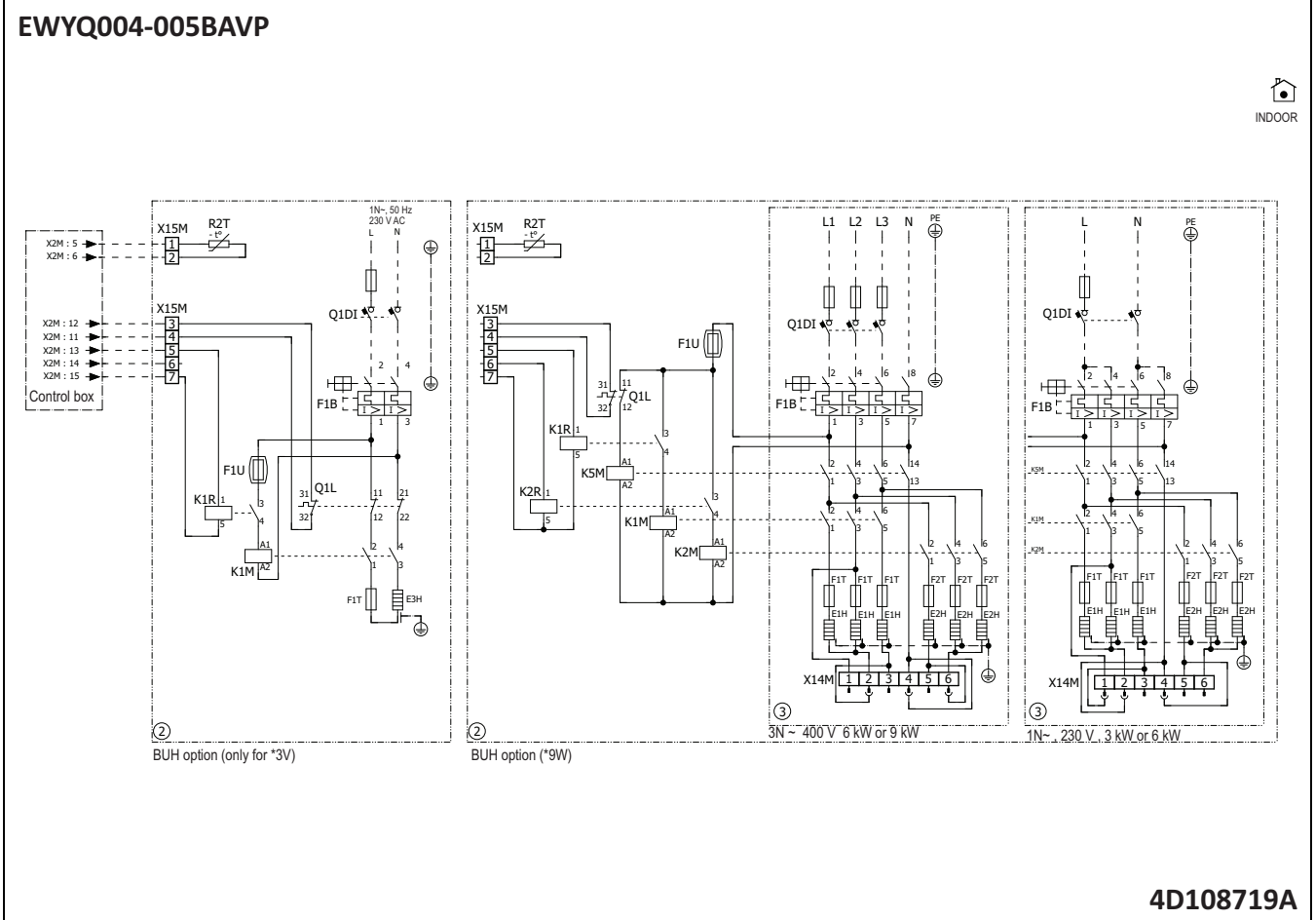
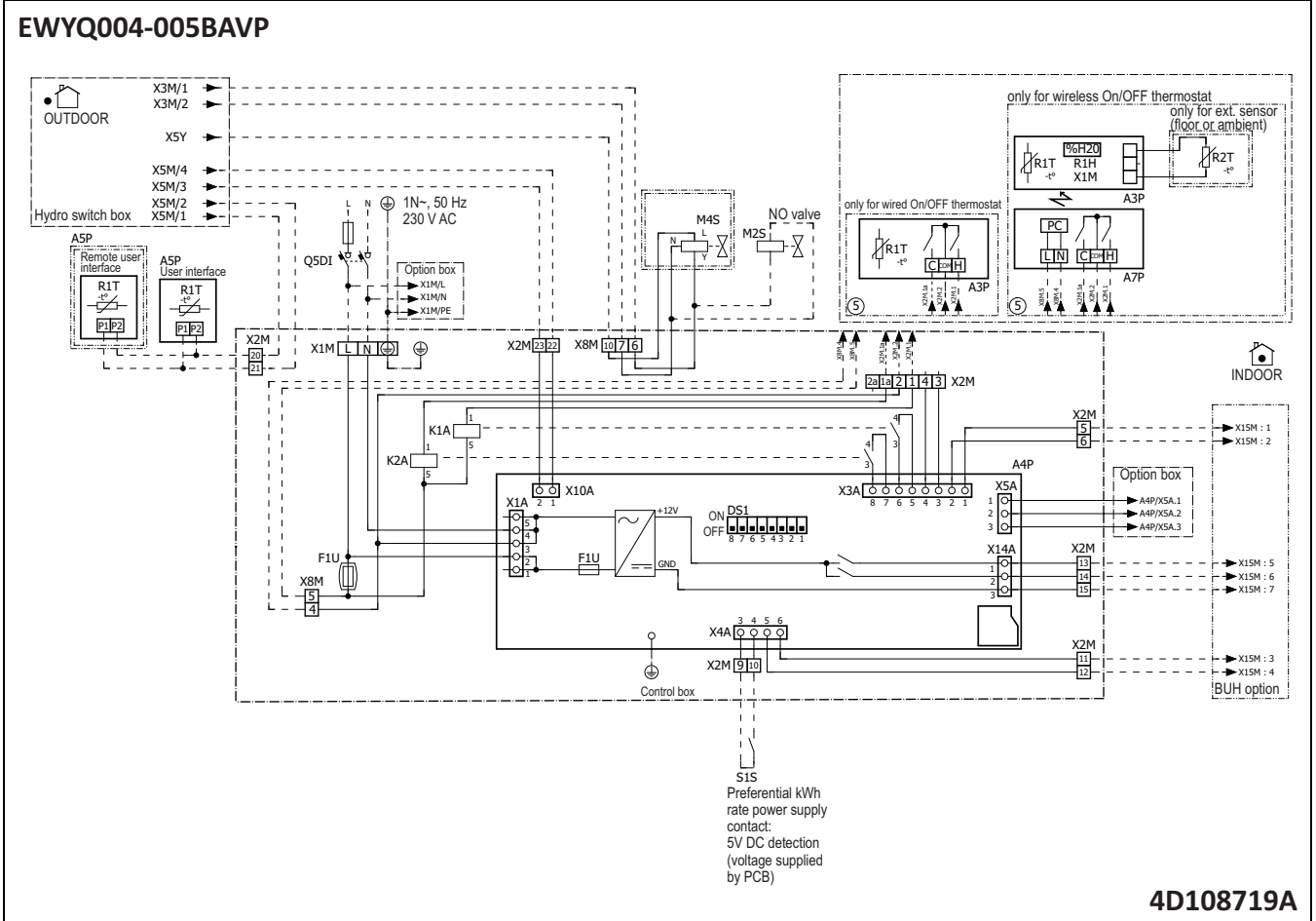

8 Wiring diagrams

8 - 1 Wiring Diagrams - Single Phase

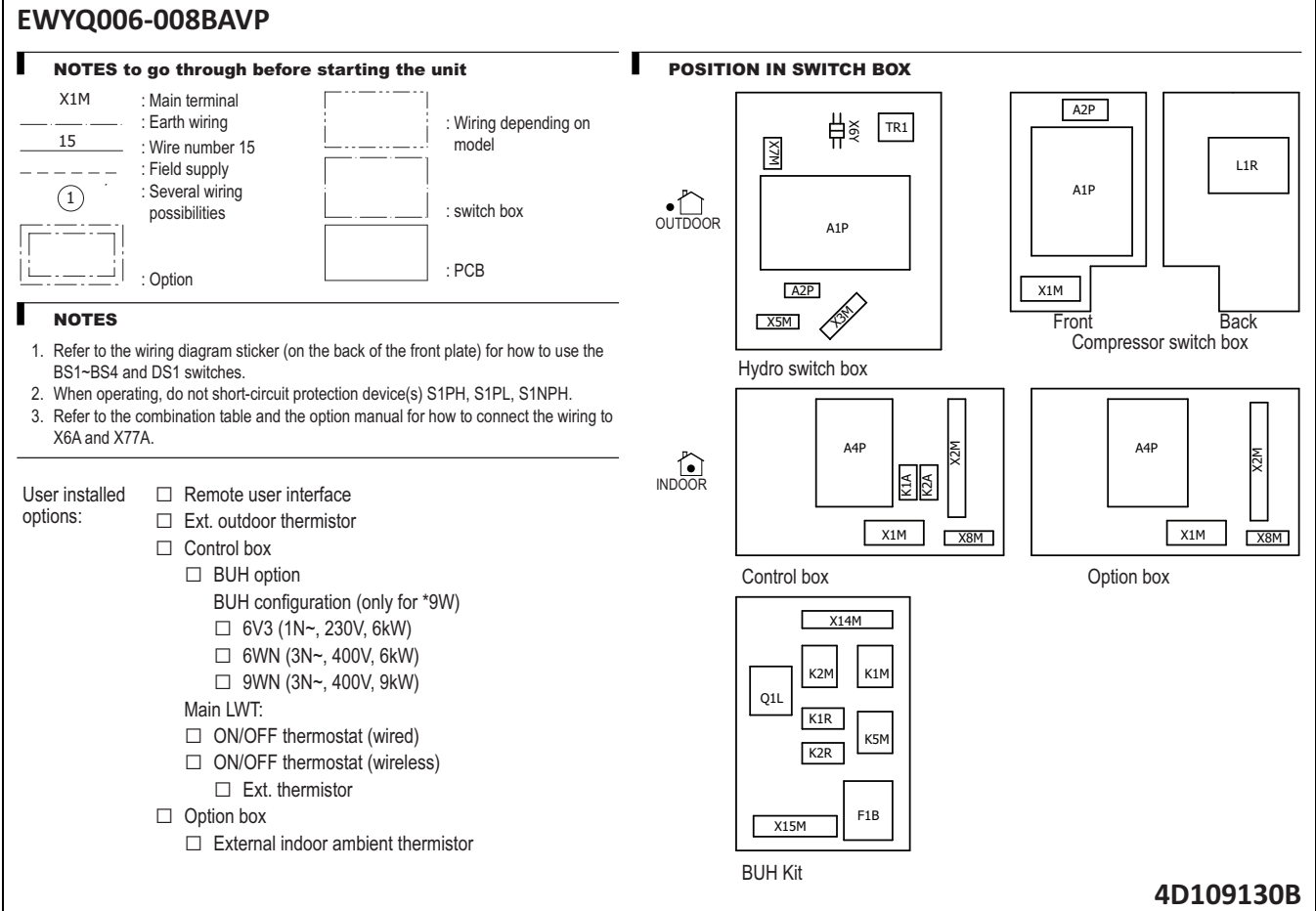
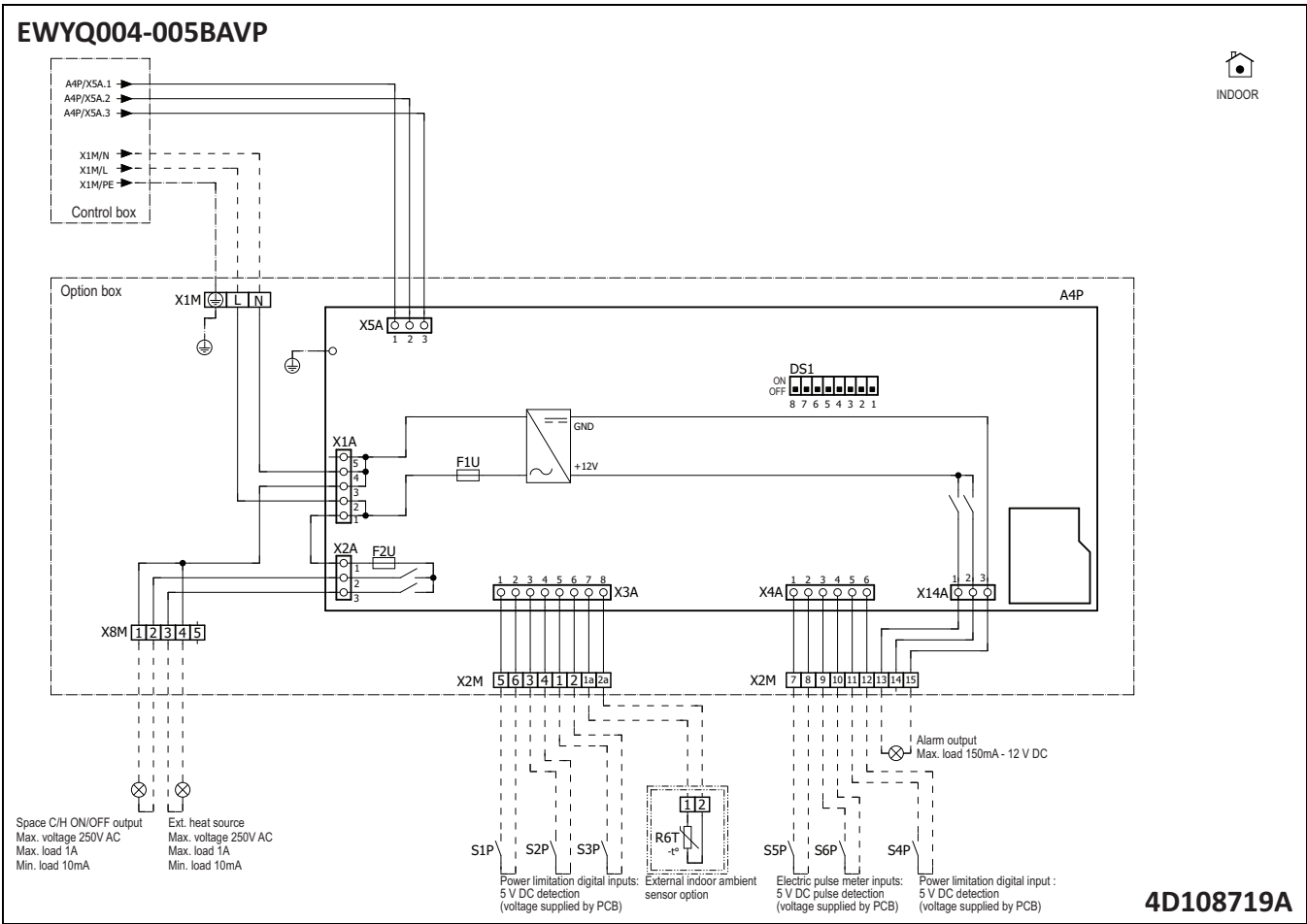

8 Wiring diagrams

8 - 1 Wiring Diagrams - Single Phase

8

EWYQ006-008BAVP

LEGEND (Outdoor compressor)

Part n°	Description
A1P	Printed circuit board (main)
A2P	Printed circuit board
BS1-BS4 (A2P)	Push-button switch
C1-C3 (A1P)	Capacitor
DS1(A2P)	Dipswitch
E1H	* Bottom plate heater
F1U (A1P)	Fuse T 6 A 250 V
F2U (A1P)	Fuse T 31,5 A 250 V
F6U (A1P)	Fuse T 3,15 A 250 V
F7U-F8U	* Fuse F 1 A 250 V
H1P-H7P (A2P)	Light-emitting diode (service monitor is orange)
HAP (A1P)	Light-emitting diode (service monitor is green)
K1R (A1P)	Magnetic relay (Y1S)
K11M (A1P)	Magnetic contactor
K2R, K10R, K13R-K15R (A1P)	Magnetic relay
L1R	Reactor
M1C	Compressor motor
M1F	Fan motor
PS (A1P)	Switching power supply
Q1DI	Earth leakage circuit breaker (30mA)
R1T	Thermistor (air)
R2, R4-R6 (A1P)	Resistor

LEGEND (Outdoor Hydro)

Part n°	Description
R2T	Thermistor (discharge)
R3T	Thermistor (suction)
R4T	Thermistor (heat exchanger)
R5T	Thermistor (heat exchanger middle)
R6T	Thermistor (liquid)
R7T-R9T (A1P)	Thermistor (positive temperature coefficient)
RC (A1P)	Signal receiver unit
S1NPH	Pressure sensor
S1PH	High pressure switch
S1PL	Low pressure switch
TC (A1P)	Signal transmission circuit
V1D-V3D (A1P)	Diode
V1R (A1P)	IGBT power module
V2R (A1P)	Diode module
V1T-V2T (A1P)	Insulated gate bipolar transistor (IGBT)
X1M	Terminal strip
Y1E	Electronic expansion valve
Y1S	Solenoid valve (4-way valve)
Z1C-Z6C	Noise filter (ferrite core)
Z1F-Z3F (A1P)	Noise filter
LA, NA, HR1-4, U, V, W, X*A, (A1P~A2P)	Connector

* : optional
: field supply

4D109130B

EWYQ006-008BAVP

LEGEND (Indoor control box)

Part n°	Description
A3P	* ON/OFF thermostat (PC=power circuit)
A4P	* Extension PCB (control, optional)
A5P	User interface PCB
A7P	* Receiver PCB (wireless On/OFF thermostat)
DS1(A4P)	* Dipswitch
F1U	Fuse T 5 A 500 V
F1U (A4P)	Fuse T 2 A 250 V
K1A	Relay for heating
K2A	Relay for cooling
M2S	# Shut-OFF Valve
M4S	* Valve Kit
PC (A7P)	Power Circuit
Q5DI	Earth leakage circuit breaker
R1H (A3P)	* Humidity sensor
R1T (A3P)	* Ambient sensor On/OFF thermostat
R1T (A5P)	Ambient sensor user interface
R2T	* Ext. indoor floor/ambient thermistor
S1S	# Preferential kWh rate PS contact
X*A (A4P)	Connector
X*M	Terminal strip

LEGEND (Indoor BUH option)

Part n°	Description
E1H	BUH element (1 kW)
E2H	BUH element (2 kW)
E3H	BUH element
F1B	* Overcurrent fuse BUH
F1T, F2T	* Thermal fuse backup heater
F1U	Fuse T 5 A 500 V BUH option
K1M	* Contactor BUH (step 1)
K1R	* Relay backup heater (step 1)
K2M	* Contactor BUH (step 2) (only *9W)
K2R	* Relay backup heater (step 2) (only *9W)
K5M	* Safety contactor BUH (only *9W)
Q1DI	# Earth leakage circuit breaker
Q1L	* Thermal protector backup heater
R2T	* Outlet backup heater thermistor
X*M	Terminal strip

LEGEND (Indoor option box)

A4P	Extension PCB(control, optional)
DS1(A4P)	Dipswitch
F1U (A4P)	Fuse T 2 A 250 V
F2U (A4P)	Fuse T 2 A 250 V for 3 way valve
R6T	* Ext. indoor ambient sensor option
S1-4P	# Digital power limitation input 1-4
S5P-S6P	# Electrical meters
X*A (A4P)	Connector
X*M	Terminal strip

* : optional
: field supply

4D109130B

8 Wiring diagrams

8 - 1 Wiring Diagrams - Single Phase

8

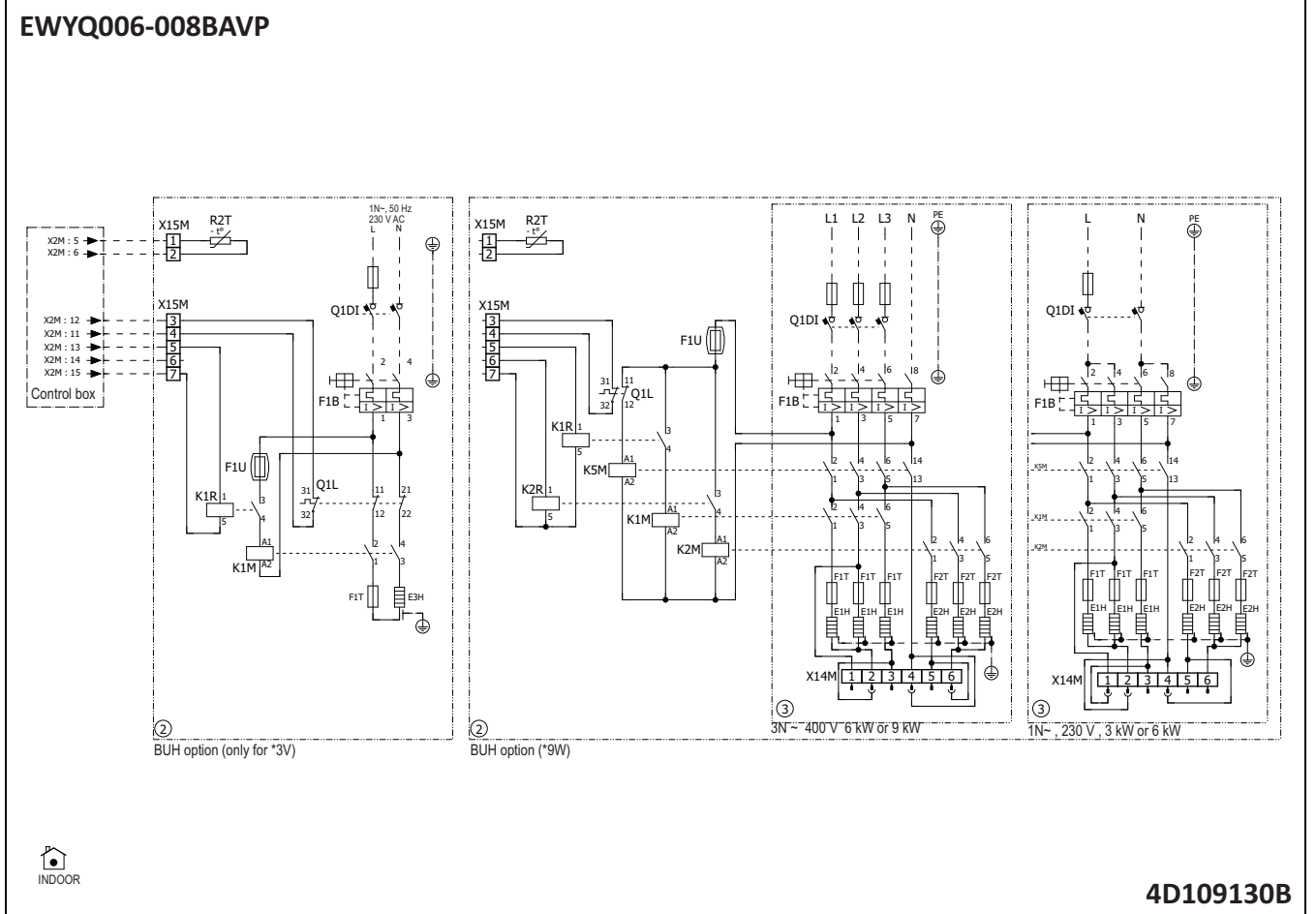
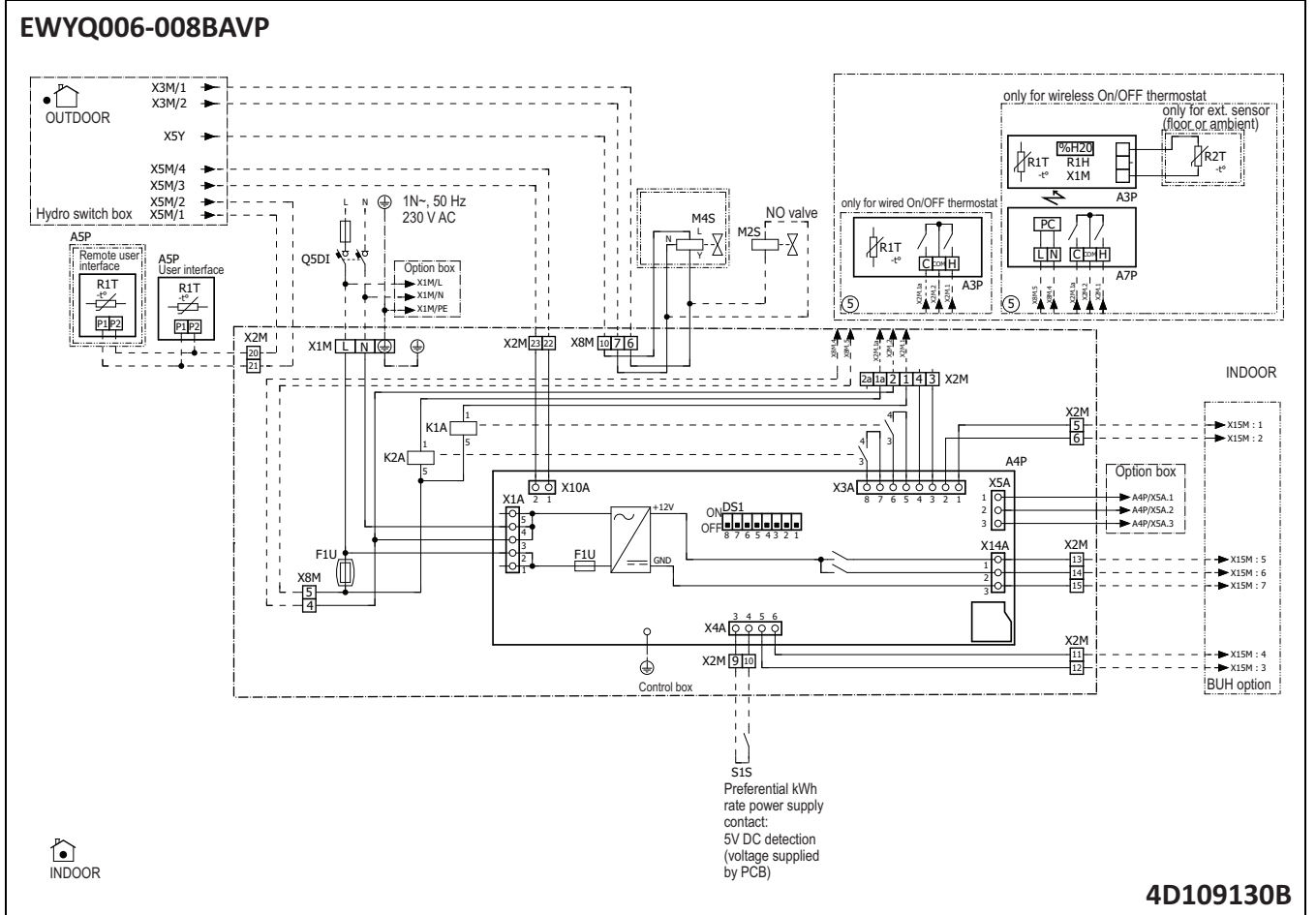

9 External connection diagrams

9 - 1 External Connection Diagrams

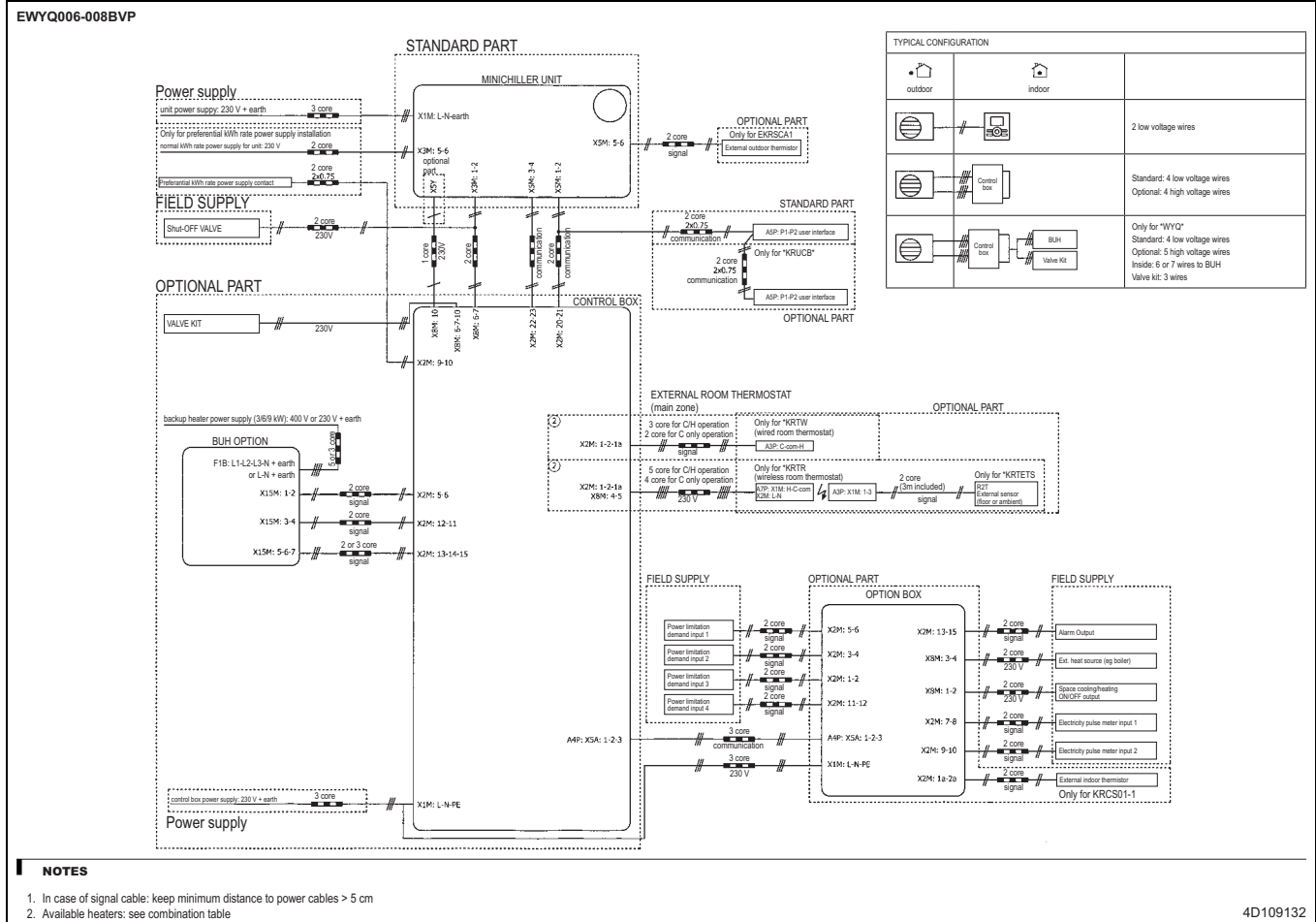
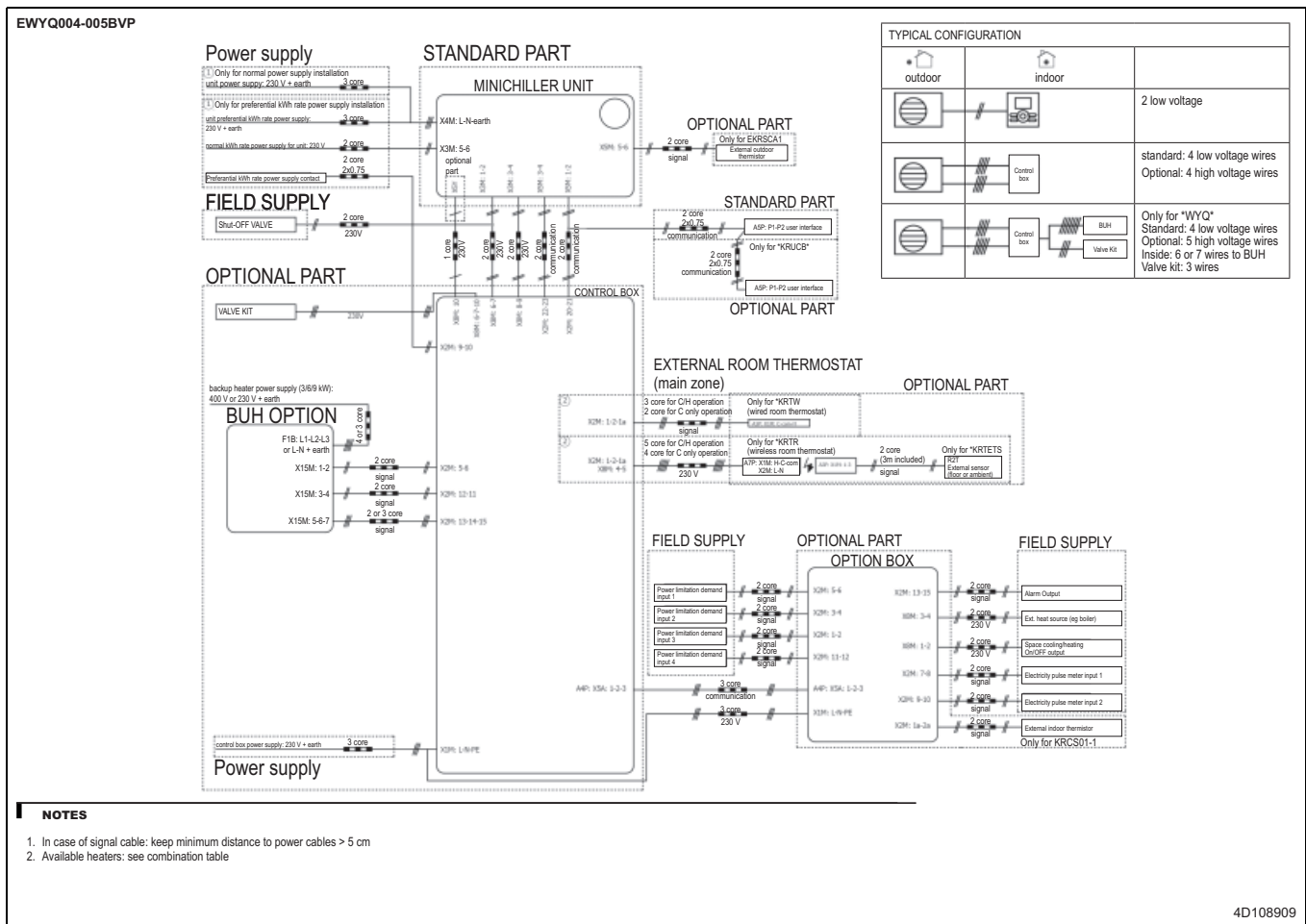

10 Sound data

10 - 1 Sound Pressure Spectrum - Cooling

10

EWYQ004-005BVP

Cooling

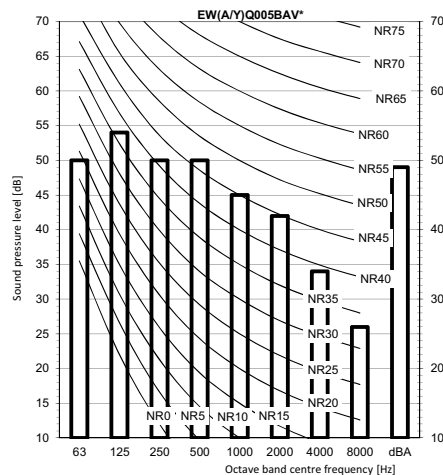
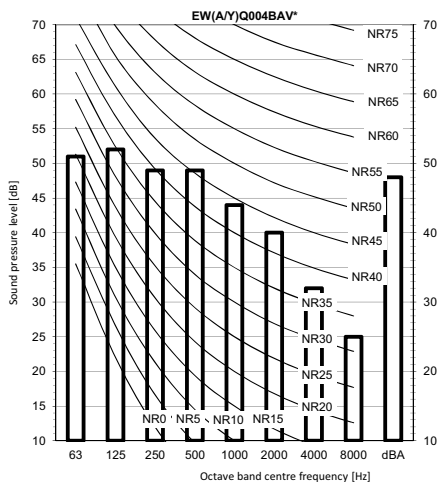

Notes

1. Data is valid at free field condition.
Measured in a semi-anechoic chamber
2. Data is valid at nominal operation condition.
3. dBA = A-weighted sound pressure level (A scale according to IEC).
4. Reference acoustic pressure 0 dB = 20 μPa
5. If the sound is measured under actual installation conditions, the measured value will be higher due to environmental noise and sound reflections.

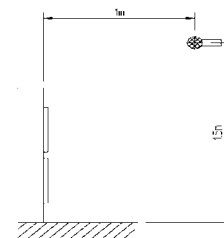

Measuring location (discharge side)

3D109245

EWYQ006-008BVP

Cooling

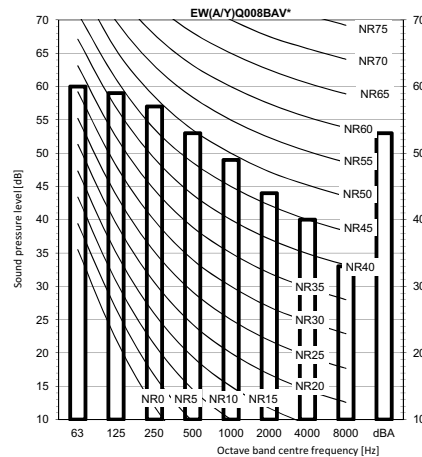
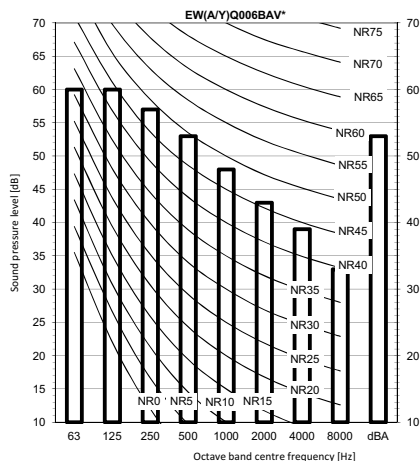

Notes

1. Data is valid at free field condition.
Measured in a semi-anechoic chamber
2. Data is valid at nominal operation condition.
3. dBA = A-weighted sound pressure level (A scale according to IEC).
4. Reference acoustic pressure 0 dB = 20 μPa
5. If the sound is measured under actual installation conditions, the measured value will be higher due to environmental noise and sound reflections.

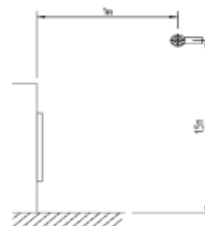

Measuring location (discharge side)

3D109725

10 Sound data

10 - 2 Sound Pressure Spectrum - Heating

EWYQ004-005BVP

Heating

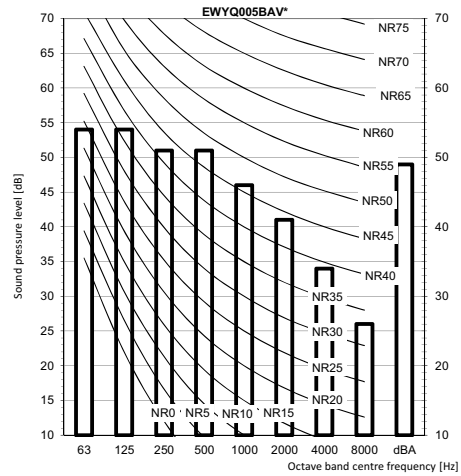
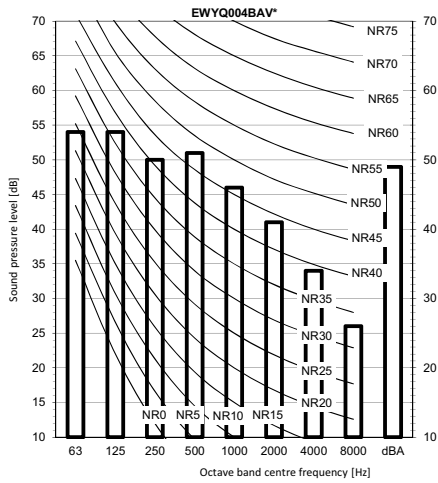

Notes

1. Data is valid at free field condition. Measured in a semi-anechoic chamber.
2. Data is valid at nominal operation condition.
3. dBA = A-weighted sound pressure level (A scale according to IEC).
4. Reference acoustic pressure 0 dB = 20 μPa
5. If the sound is measured under actual installation conditions, the measured value will be higher due to environmental noise and sound reflections.

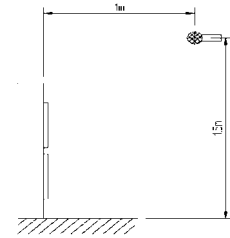

Measuring location (discharge side)

3D109246

EWYQ006-008BVP

EWYQ006BAV*

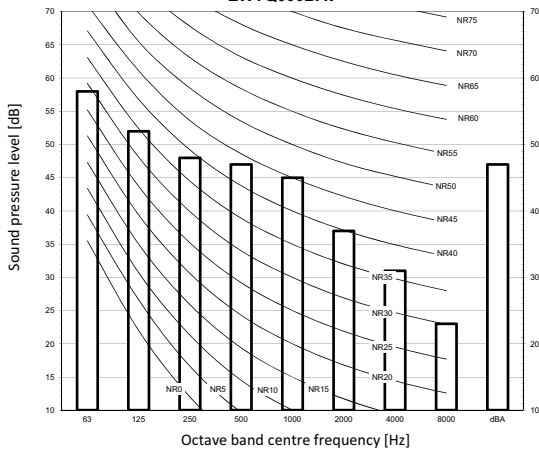

EWYQ008BAV*

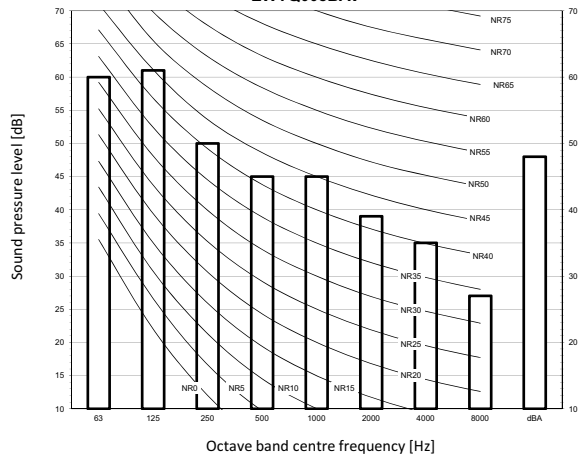

Notes

1. Data is valid at free field condition. Measured in a semi-anechoic chamber.
2. Data is valid at nominal operation condition.
3. dBA = A-weighted sound pressure level (A scale according to IEC).
4. Reference acoustic pressure 0 dB = 20 μPa
5. If the sound is measured under actual installation conditions, the measured value will be higher due to environmental noise and sound reflections.

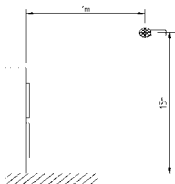

Measuring location (discharge side)

3D109726

11 Installation

11 - 1 Installation Method

11

EWYQ004-005BVP

Minimum space for air passage
Wall height on air outlet side < 1200 mm

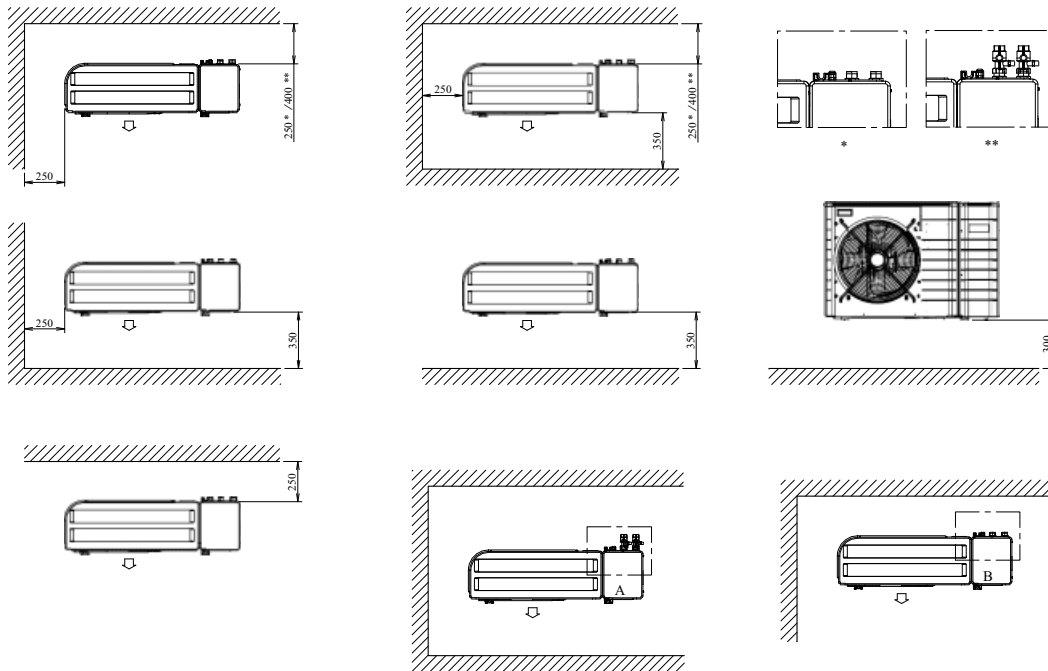

3D097314A

EWYQ006-008BVP

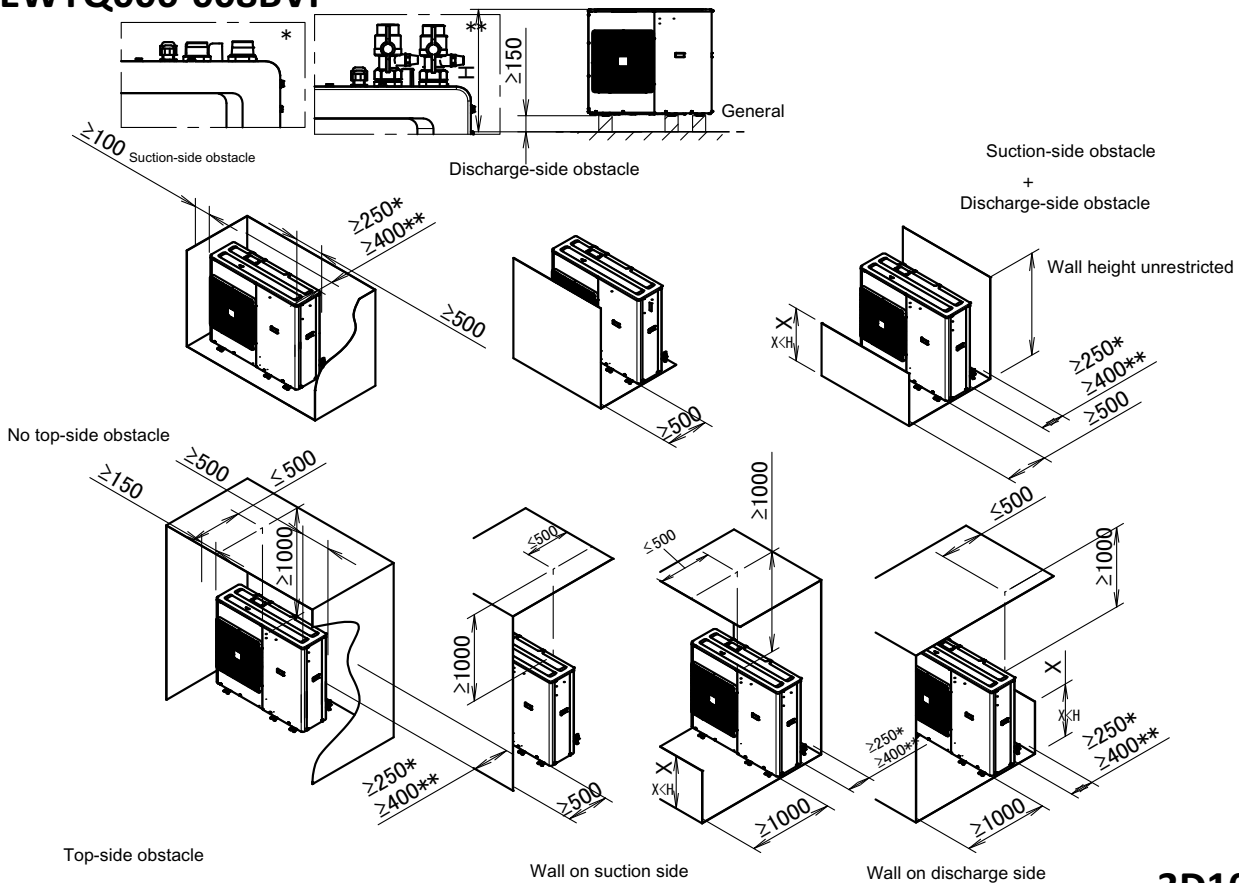

3D109719

12 Operation range

12 - 1 Operation Range

EWYQ004-005BVP

Space heating
4 & 5 kW class

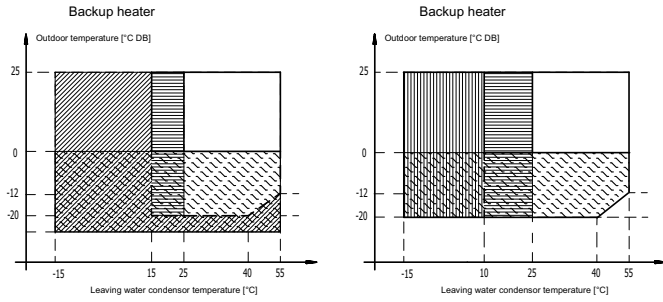

- Legend**
- Backup heater only operation
No outdoor unit operation
 - Pull-up operation
Outdoor unit operation if setpoint $\geq 25^{\circ}\text{C}$
 - Circulation pump
 - Prevent the system from freezing by adding glycol.

Remark
In restricted power supply mode, the outdoor unit and backup heater can only operate separately.

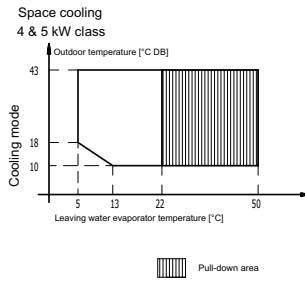

Pull-down area

3D109243

12 Operation range

12 - 1 Operation Range

12

EWYQ006BAVP
EWYQ008BAVP

Space heating

With backup heater option kit

·6 & 8· kW class

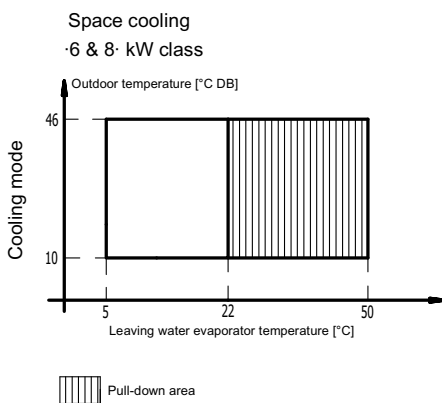
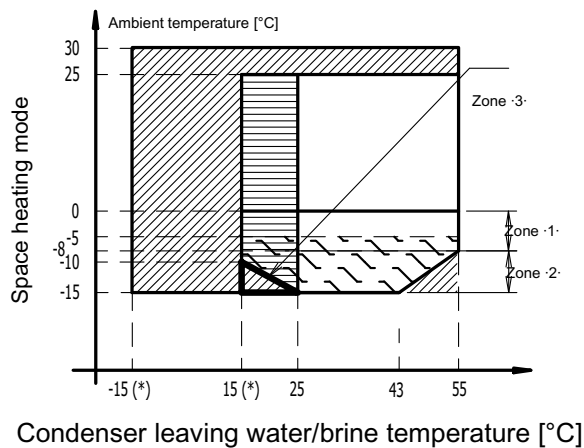
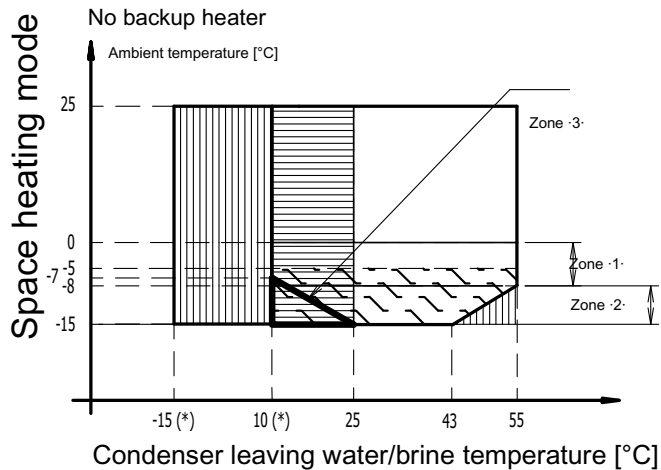

(*) Minimum condenser entering water/brine temperature [°C]

If negative ambient temperatures are expected, both in operation or at standstill, take adequate countermeasures against freezing.

Add the required amount of glycol to the system.

OR

Use the model with heater tape protection.

Zone -1·

Only operate in this area if using brine with a minimum glycol percentage of ·20·%.

OR

Use the model with heater tape protection.

If operation in zone -3· is expected, add the required amount of glycol.

Zone -2·

Only operate in this area if using brine with a minimum glycol percentage of ·35·%.

OR

Use the model with heater tape protection.

If operation in zone -3· is expected, add the required amount of glycol.

Zone -3·



Only operate in this area if using brine with a minimum glycol percentage of ·35·%.

Legend



Pull-up operation
Outdoor unit operation if setpoint \geq -25°C



Circulation pump operation only



In case of high humidity conditions (relative humidity > 92·%, outdoor ambient temperatures < 5·°C), an optional bottom plate heater is required. This to avoid freeze-up of the outdoor unit.



Backup heater only operation
No outdoor unit operation

3D109723A

13 Hydraulic performance

13 - 1 Static Pressure Drop Unit

13

EWYQ006-008BVP

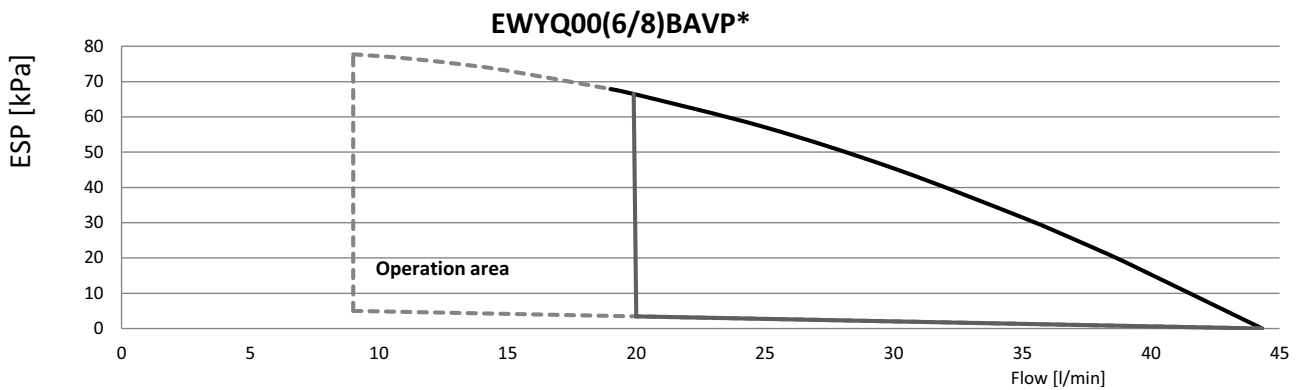
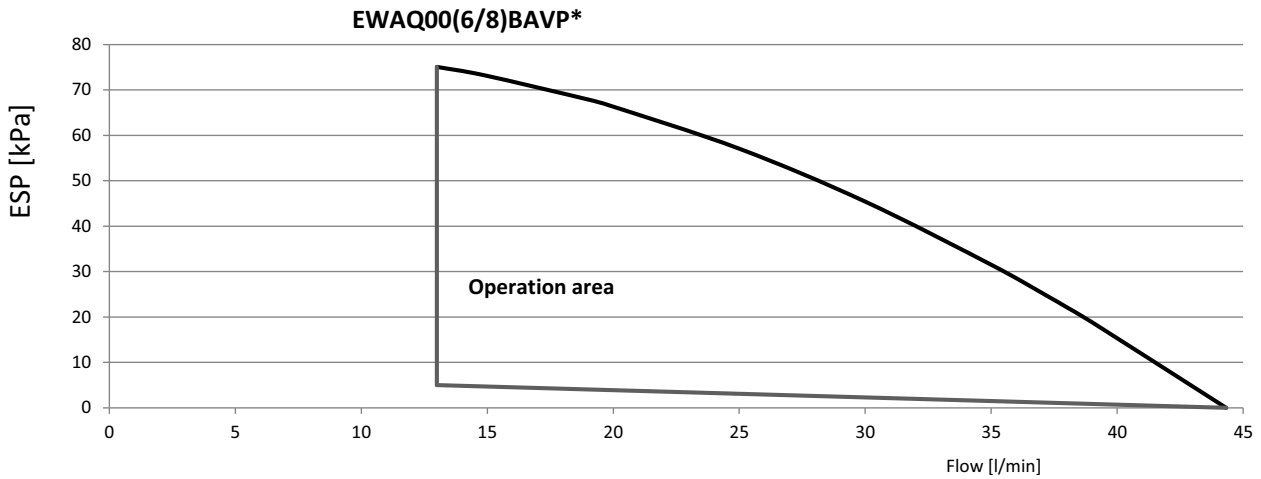

ESP = External static pressure [kPa] Space heating/cooling circuit
 Flow = Water/glycol flow through the unit Space heating/cooling circuit

Notes

- See dashed lines
 The operation area is extended to lower flow rates only in case the unit operates with heat pump only, and the temperature of the flow medium is sufficiently high.

 This does not apply to start-up operation, defrost operation, and backup heater operation in case a backup heater is installed.
- The higher operation range limit is only valid if the flow medium is water. If glycol is added to the system, the limit is lower.
- Selecting a flow outside the operating area can damage the unit or cause the unit to malfunction.

 See also the minimum and maximum allowed water flow range in the technical specifications.

4D109727A

Daikin Europe N.V. Naamloze Vennootschap - Zandvoordestraat 300, B-8400 Oostende - Belgium - www.daikin.eu - BE 0412 120 336 - RPR Oostende

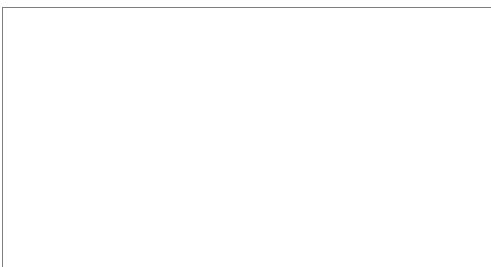

EEEN19 05/19



Daikin Europe N.V. participates in the Eurovent Certified Performance programme for Liquid Chilling Packages and Hydronic Heat Pumps, Fan Coil Units and Variable Refrigerant Flow systems. Check ongoing validity of certificate: www.eurovent-certification.com



The present leaflet is drawn up by way of information only and does not constitute an offer binding upon Daikin Europe N.V.. Daikin Europe N.V. has compiled the content of this leaflet to the best of its knowledge. No express or implied warranty is given for the completeness, accuracy, reliability or fitness for particular purpose of its content and the products and services presented therein. Specifications are subject to change without prior notice. Daikin Europe N.V. explicitly rejects any liability for any direct or indirect damage, in the broadest sense, arising from or related to the use and/or interpretation of this leaflet. All content is copyrighted by Daikin Europe N.V.