



DESCRIPTION

V54202

Thermo electrical actuator 230V ON/OFF-PWM N.C. (Normally Closed), adaptor VA64 for installation included:

- Pettinaroli's radiator valve with thermostatic option (M28x1.5)
- Manifolds with valve with thermostatic option (M28x1.5)
- Pressure independent control valve EVOPICV with 3mm stroke of the control valve (91, 91X, 92 ½" and 92 ¾")

DIMENSIONS

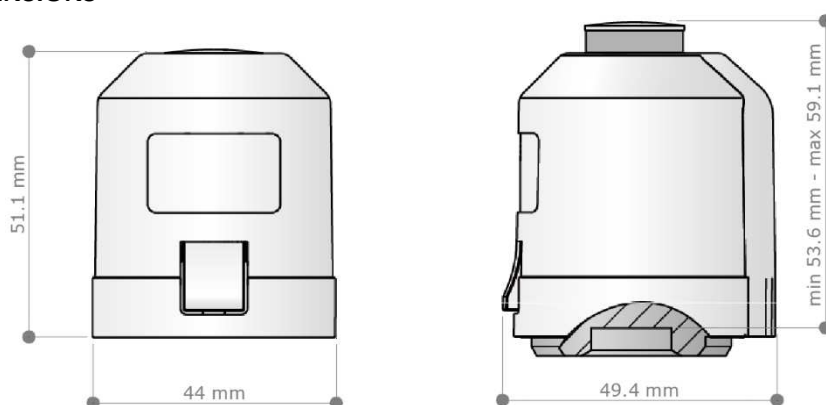

TECHNICAL DATA/ FEATURES

Type	ON/OFF-PWM - N.C.	Storage temperature	-25° / + 60 °C
Operating voltage	230Vac ± 10% - 50/60 Hz	Ambient temperature	0° / + 60 °C
Max. Inrush current	300 mA – 200 ms max	Type of protection	IP54 / II
Stroke (actuator level)	4 mm	Weight	100 g
Operating Power	2 W	Colour	grey RAL7035
Opening/Closing time	~3 min.	Connecting cable type	H03VV - 2 x 0.75 mm ²
Actuating force	100 N ± 5 %	Connecting cable length	1 m
Fluid temperature	0 / + 100°C	Surge protection	2.5kV (EN 60730-1)
		Adaptor included	VA64

The actuators V54202 are a 230V thermoelectric valve driver suitable to control the flow on the heating and/or cooling installation in function of the room temperature value. If the installer needs a supplementary control (i.e. pump control) in function of the actuator state (Open/close) is recommended to adopt relay (look the specify paragraph dedicated to the wiring diagrams – Figure n°3).

The actuators V54202 are N.C. so, if the power is off, it will close; the actuator V54202 could be connected to “voltage free” room thermostat. To have more details regarding the wiring connection look the specific paragraph.

APPROVALS



WIRING DIAGRAMS

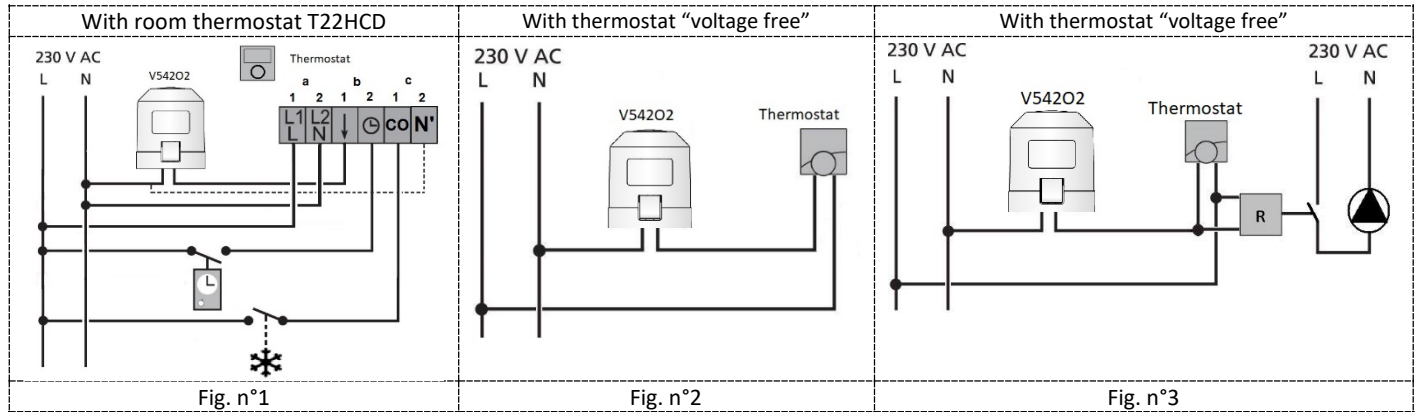

LEGENDA

- N = neutral
- F = Line
- R = Relay

INSTALLATION NOTES

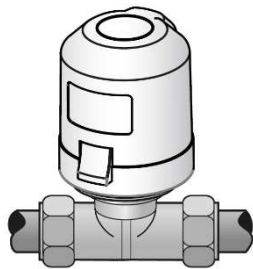

Fig.4

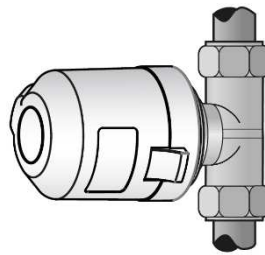

Fig.5



Fig.6

Vertical (Fig.4) or Horizontal (Fig.5) installation are recommended. An upside down (Fig.6) installation may reduce product life through special circumstances (i.e. contaminated water).

Before installing the actuator, make sure the VA64 adaptor has been correctly screwed on the valve.

FIRST OPEN FUNCTION

The actuators V542O2 are Normally Close (N.C.), so on the de-energized state, they will close from the valve. Nevertheless the installation onto the “valve” is simple thanks to the “First Open Function”: the actuator is delivered partially open.

Applying the operating voltage for more than 6 minutes the “First-Open function” will unlocked.

It’s recommended to apply the actuator only after that all the hydraulic installation phase is completed.

CHARACTERISTIC CURVE

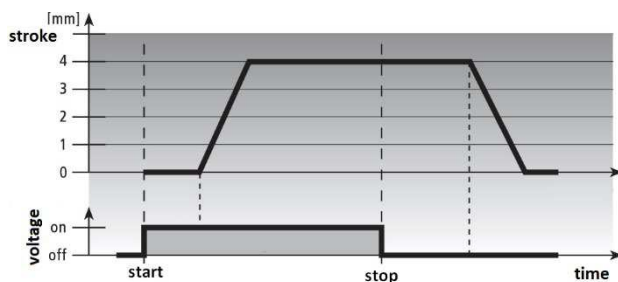

The diagram beside shows the characteristic line of the actuators V542O2 24V ON/OFF-PWM N.C. (Normally Close).