



DESCRIPTION

M63

Electric actuator 24V with proportional control mode (0-10V) or 2 / 3 points for six-way ballvalves (**63 series**). It enables the automatic winter-summer change-over or it eventually allows the control of radiant ceilings, fan coil units and chilled beams.

DIMENSIONS

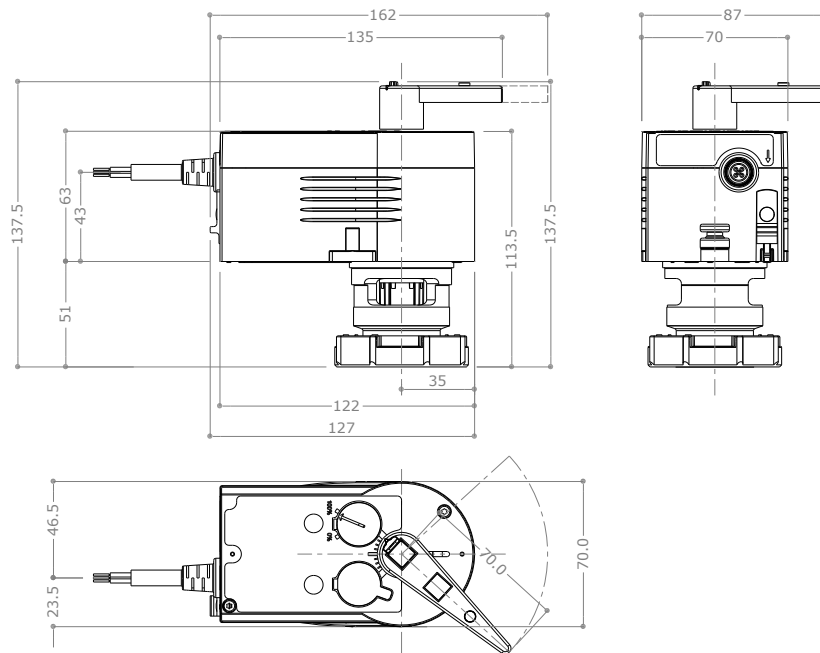

APPLICATION FIELD

The **M63** electric actuator is an actuators fed at 24 V. It moves the Pettinaroli six-way valve **63 series**. According to the system complexity, the actuator can be managed by a BMS or a room thermostat choosing among the following modes:

- Proportional 24V with 0/10V signal
- 2 points control
- 3 points control

For further details, see the section “Electric connection”. The Pettinaroli **M63** has a release button and a handle to manage it manually.

TECHNICAL FEATURES

Supply voltage	24VAC ±20% - 50-60Hz 24VCC -10% ÷ +20%	Admissible ambient humidity	5% - 95% Hr. No condensing
Max power consumption	4.9 W – 8.7 VA	Max temperature medium	100°C
Running time	120s (#)/35/60	Admissible ambient temperature	-10°C ÷ +55°C
Angle of rotation	0°-90°	Type of protection (EN60529)	IP54
Response time	200 ms	Protection class (IEC60730)	III
Torque	8 Nm (120 s and 60 s) – 4 Nm (35 s)	Housing color	Black
Power cable	5x 0.5 mm ²	Cover color	Light blue RAL5015
Power cable length	1.2 m	Weight	700 g
(#)  120s			

APPROVALS



EMC directive 2004/108/EC: EN 61000-6-1, EN 61000-6-3 EN 61000-6-4

Directive 2006/95/EC: Machine Directive (EN 1050)

RUNNING TIME SELECTION

The actuator running time can be set by means of dip-switches. In order to reach them, take the cap away: this cap is placed on the upper cover, as shown by the picture beside.

The table below summarizes the three different modes which can be chosen. To ensure proper operation of the assembly valve/actuator, only the 3 proposed configurations are strictly suggested:

Switch position	Running time
	120 s ± 4 (default)
	60 s ± 4
	35 s ± 4

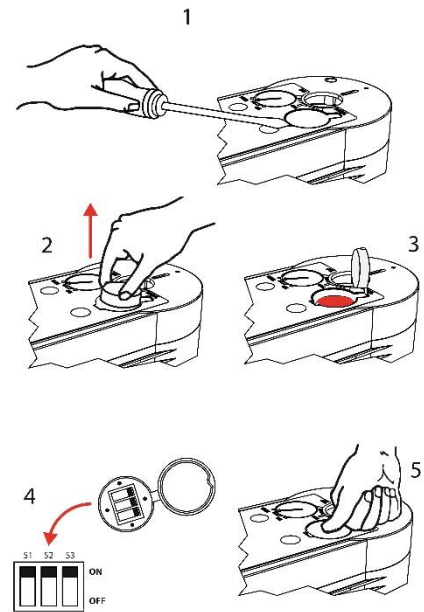

The power consumption changes according to the selected running time; the table below shows that:

Running time	Status	Active power (W)	Apparent power (VA)
35 s	Operation	2.45	4.75
35 s	Stand-by	0.35	0.8
60 s	Operation	4.9	8.7
60 s	Stand-by	0.35	0.75
120 s	Operation	2.25	4.3
120 s	Stand-by	0.35	0.75

INSTALLATION ON THE 63 SERIES VALVE

Strictly follow the procedure in order to correctly couple the **M63** actuator with the six-way ballvalve **63 series**:

1. The fixing ring must be in the horizontal position, not in the diagonal one.

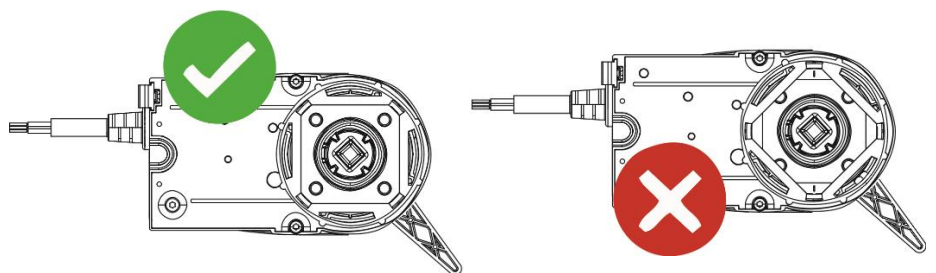

2. Place the stem of the six-way **63 series** valve at 90° which means getting the 1 and 4 ways closed and the 5 and 6 fully open.
3. Set the actuator at 100% by means of the manual release.



4. Fit the actuator onto the valve following the picture beside.

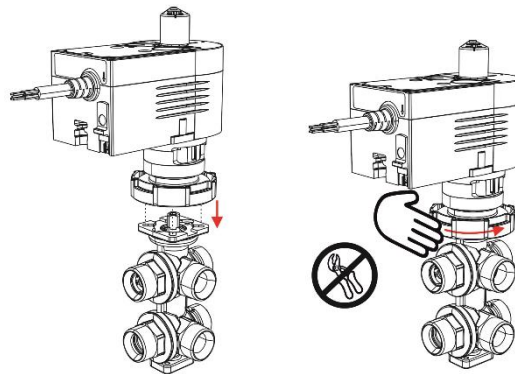

ELECTRICAL CONNECTIONS

LEGENDA

MM	01	02	03	05
BU	BN	BK	RD	GY
Blue	Brown	Black	Red	Grey

Every kind of electrical connection must be done by qualified staff and without voltage. Do not open the actuator to reach clamps.

CONTROL MODE: PROPORTIONAL 0-10V

Hook up just one wire between the brown and black ones according to wanted rotation and to control signal increase.

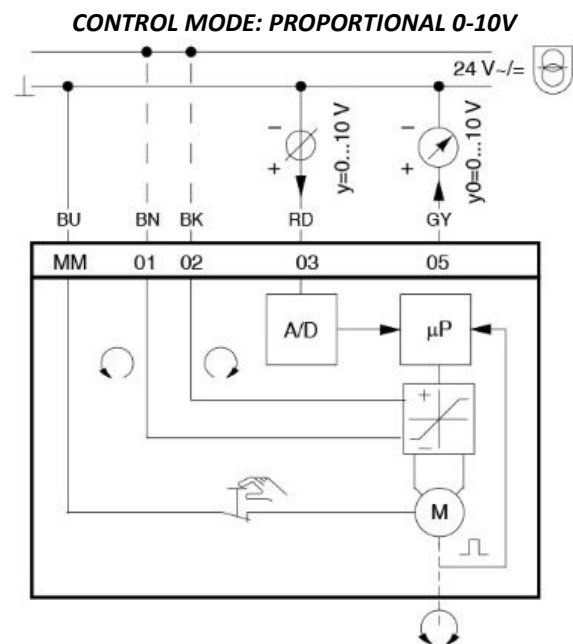

CONTROL MODE: 2 POINTS

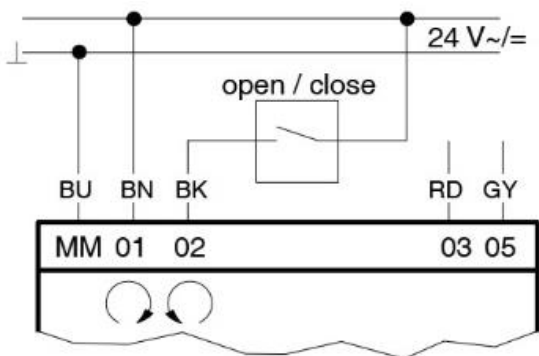

CONTROL MODE: 3 POINTS

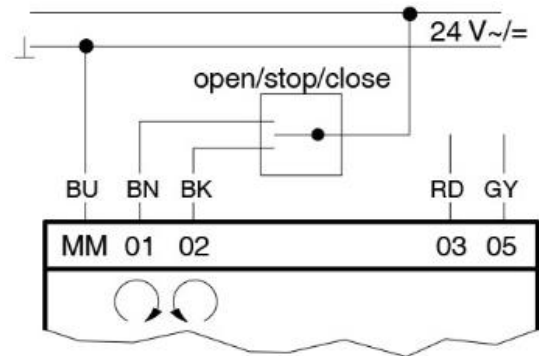

COMMISSIONING

Proportional 0-10V control mode: when the actuator M63 is powered, an internal control cycle automatically starts. This cycle lasts about 2 minutes. The actuator checks the end points on their extreme positions (0% and 100%). Then the actuator places itself:

- position 0 %, in other words, ways 1 and 4 fully open, if the brown wire BN is connected and with control signal 0 V;
- position 100 %, ways 1 and 4 fully closed, if the black wire is connected and with control signal 0 V;

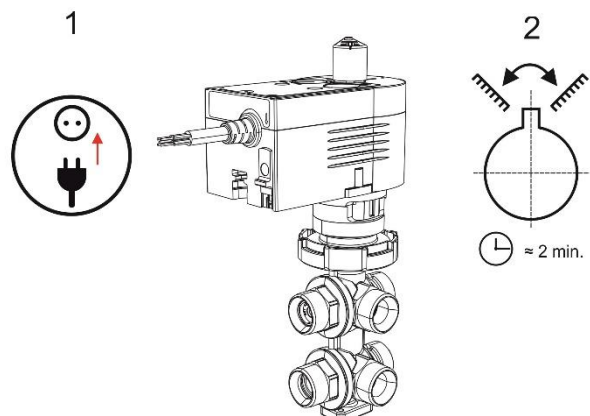

2 points control mode: when the actuator **M63** is powered, it identifies the 100% position by itself; this means the ways 1 and 4 are fully closed. Only an external control system (e.g., room thermostat, BMS) can change this situation and opening the ways 1 and 4 while closing ways 5 and 6.

3 points control mode: when the actuator **M63** is powered, it places itself to 100% position (ways 1 and 4 closed) or to 0% position (ways 1 and 4 fully open) according to the status of the switch (thermostat): if the contact is connected to the brown wire BN it goes to 100% position, otherwise the 0% position is set.

RELEASE BUTTON

As we said before, the **M63** actuator has a release button which disables the mechanical connection between engine and shaft. Thus, valve position (open or closed) can be forced manually.

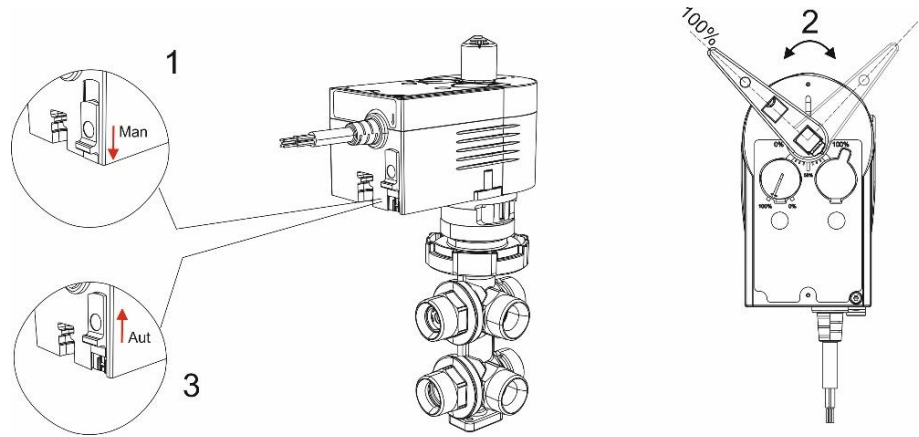

REMOVING THE ACTUATOR

In order to make the removal operation easier, the actuator **M63** should be to 100% position.

If so requested, use the release button to reach manually this position.

To remove the actuator, please follow the procedure shown beside.

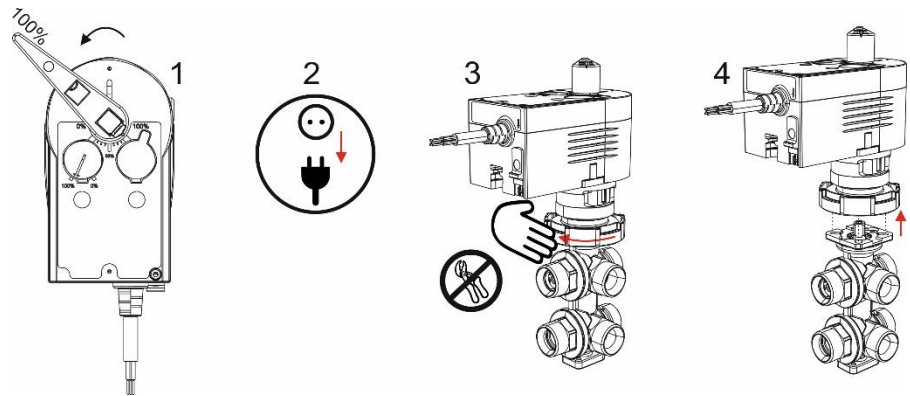

INSTALLATION

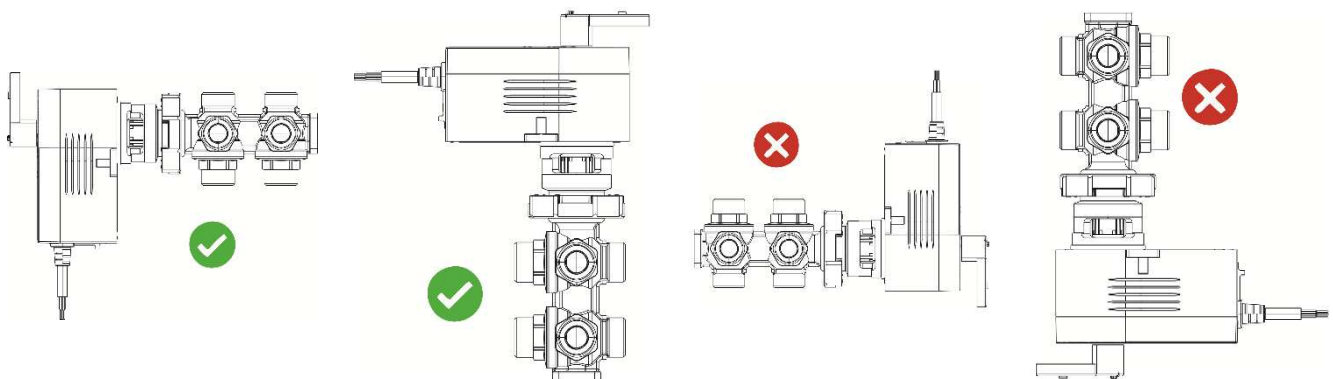

Fig.1

Fig.2

Fig.3

Fig.4

It is appropriate installing the **M63** actuator like pictures 1 or 2. Vertical or upside-down installation (pictures 3 and 4) could injure right operations and it could be dangerous, electrically speaking.

CLOSING PROCEDURE OF ALL WAYS

Follow the procedure below to contemporary close all the ways of 63 and 63/2 valves (balls in death zone), keeping the over-pressure discharge system operating at any time:

0 – 10 V control signal

- with starting position 0V (cooling side open), give a 6 V signal. Then give a 5 V signal. Brown wire connected.
- with starting position 10V (heating side open), give a 4 V signal. Then give a 5 V signal. Brown wire connected.

Viceversa if black wire is hooked up.

3 points floating

Always do a 120 s or 60 s cycle (according to selected running time) plus 10 s.

Then invert the rotation direction for:

- 65 s with 120s running time
- 32 s with 60 s running time

OPERATION CHARACTERISTIC CURVE OF THE ASSEMBLY M63 ACTUATOR AND 63 SERIES VALVE

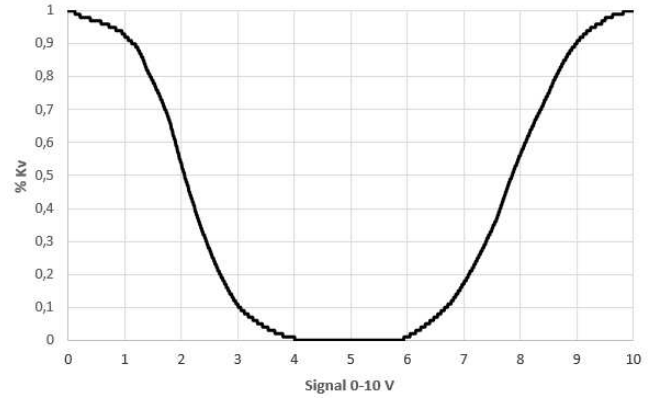
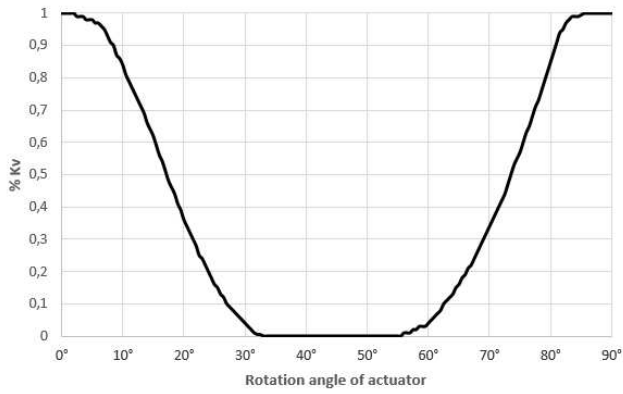

EXAMPLE OF ASSEMBLY M63 ACTUATOR WITH 63 SERIES VALVE

