



DESCRIPTION

63/2F

High flow six-way ballvalve with 3/4" M flat ends for HVAC 4 pipes applications to automatically carry out the winter-summer change-over or, potentially, the control of radiant ceilings, fan coils and chilled beams.

Available in 2 different models: **63/2F DN20 Kv_{max} 2.8** and **63/2F DN20 Kv_{max} 4**.

DIMENSIONS

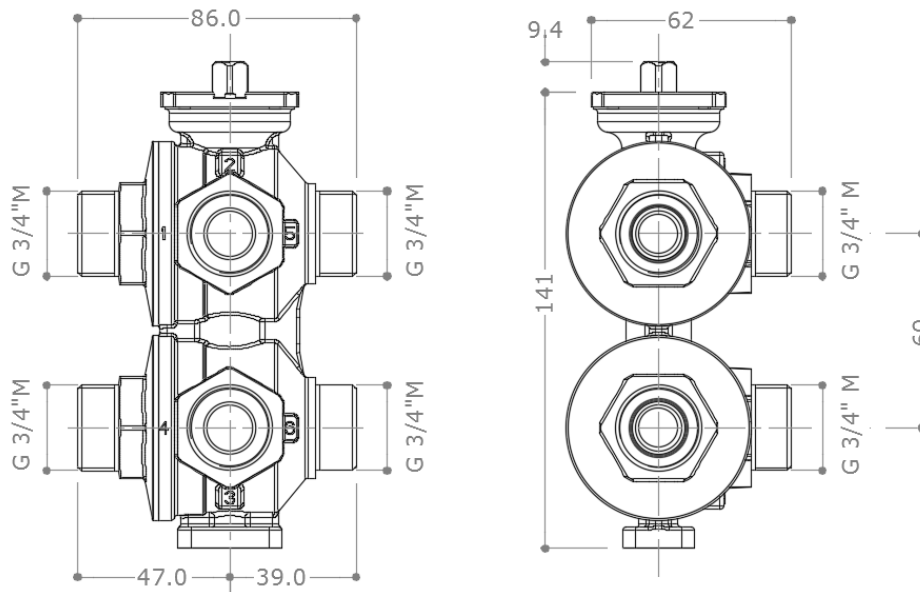

APPLICATION FIELD

The new Pettinaroli six-way ballvalve (**63/2F**) comes out of the big experience gained over many years that Pettinaroli experts have spent working on many air conditioning projects all-over the Europe. The wider and wider realization of 4 pipes conditioning systems and technical/practical issues to move simultaneously by actuators two or four valves have pushed technicians to look for compact, reliable and easier solutions like the Pettinaroli **63/2F** six-way ballvalve.

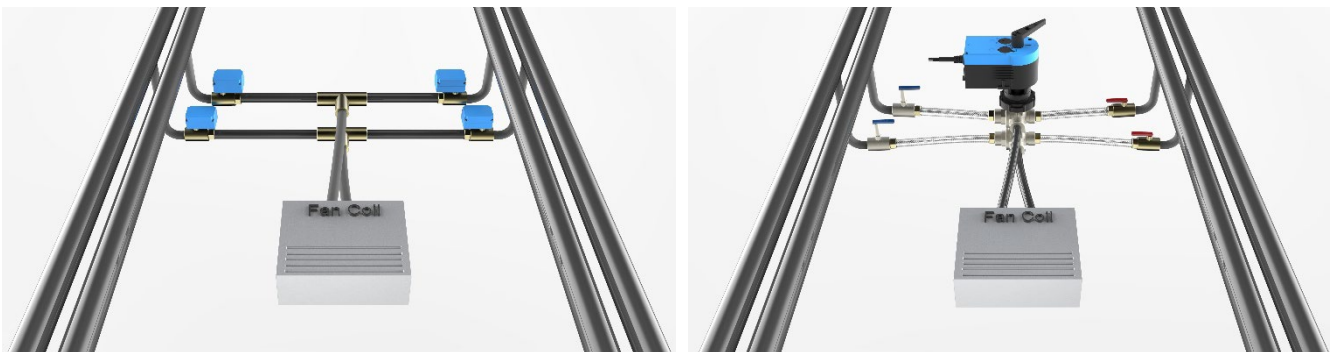

The simultaneous 90° rotations of the two balls, moved just by one stem, opens supply and return ways on one side (for example, ways n. 1 and n. 4) and closes at the same time the other side (ways n. 5 and n. 6). It avoids any mixing between flows.

For its suitable operation, the Pettinaroli six-way ballvalve **63/2F** has to be equipped with the rotating electric engine **M63 24V**. The electric actuator is supplied separately. It makes the change-over automatic. It also secondary allows the control of the water flow by means of a local (room thermostat) or centralized (BMS) device. For further information, see their own technical datasheets.

The **63/2F** valve has a flange to connect rotating actuators which is compatible with F03 an F04 types, as the standard EN ISO 5211 indicates.

STRUCTURE AND COMPONENTS

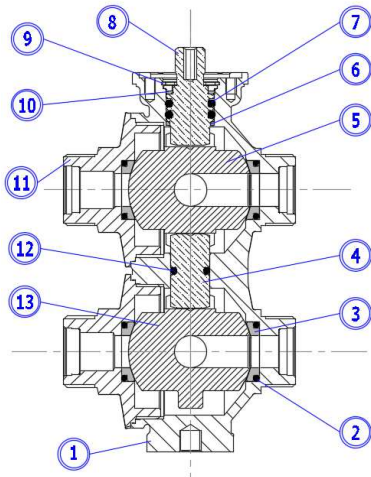

1	Body	CW602N (EN 12167) CuZn36Pb2As
2	O-ring	EPDM - Perox
3	Seats	PTFE
4	Stem	CW614N (EN 12164) CuZn39Pb3 chrome plated
5	Ball	CW617N (EN 12165) CuZn40Pb2 chrome plated
6	Anti-friction seat	PTFE
7	O-ring	EPDM - Perox
8	Main stem	CW614N (EN 12164) CuZn39Pb3 chrome plated
9	Seeger	Phosphor bronze
10	Anti-friction seat	PTFE
11	End connection	CW602N (EN 12167) CuZn36Pb2As
12	O-ring	EPDM - Perox
13	Ball	CW617N (EN 12165) CuZn40Pb2 chrome plated

TECHNICAL FEATURES

Handled fluid	Water (glycol max 50%)	Total operation angle	90°
Min water temperature	-10 °C	First side operation angle	0-32°
Max water temperature	120 °C	“Dead zone” operation angle	32°-58°
Nominal pressure	16 bar	Second side operation angle	58°-90°
Characteristic curve	Linear	Max differential pressure	2 bar
Kv	2.8 – 2.1 – 1.6 – 1.0 – 0.7 4 – 2.5	Leakage level EN12266-1/12 – P12	Level A
Connections	G 3/4”M flat end	Weight of the valve	1850 g
Nominal diameter	DN20	Water quality - UNI 8065	Fe<0.5mg/kg Cu<0.1 mg/Kg

VALVE OPERATION

The valve is equipped with two balls with an “L” hole. A reference sign made by laser is placed on the main stem; ball position is univocally and immediately identified by this sign even once the valve is installed.

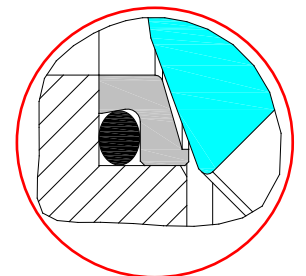
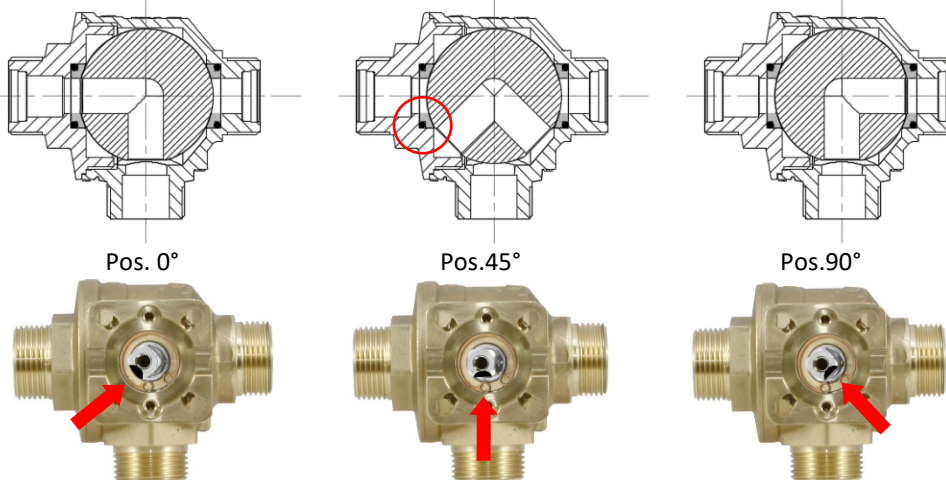

Overpressure discharge device

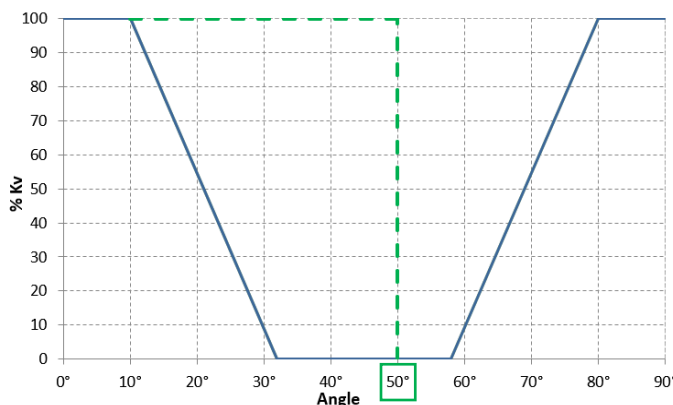

Beside the diagram shows the characteristic operation curve of the Pettinaroli six-way valve 63/2F with the stem/balls rotation. The overpressure discharge device works until 50°, as shown beside.

During the cooling season it can occur that the six-way valve is turned in close position (45°) for a long period by the installation control system (in order to save energy, when rooms are empty) or for maintenance operations; in such a situation the downstream circuit would be completely isolated from expansion vessels. In this configuration there could be the possibility that the ambient temperature rises up in those rooms where terminals are placed (chilled beams, radiant ceilings, fan coils); this is due to external heat loads. Thus, also the water inside the circuit will be in thermal equilibrium with the environment. For instance, it may happen that the ambient temperature increases up to 30°C: supposing that the water temperature was 15°C when the valve has been shut off, it would rise its temperature up to 15°C. It is widely known that a liquid in a close circuit increases its pressure when heated up without any expansion vessel. Such a circumstance might cause undesirable issues to cooling/heating terminals, both technical and esthetical.

For this reason Pettinaroli's technicians have provided the **63/2F** six-way ballvalve with a special device, as shown by the previous picture, which keeps in communication, through the way n.1, the downstream circuit with the expansion vessel of the cooling system even if the valve is closed (45°). Pettinaroli's technicians have been used an experienced technology used on compressed air ball valves (the closed valve can depressurize the controlled downstream system). Therefore every risk of overpressure inside the terminals (chilled beams, radiant ceilings, fan coils) is avoided.



For a correct installation, strictly respect flow directions, as reported by the picture beside. The milling sign on the main stem indicates the current ball position, as above-mentioned.

KV VALUES SELECTION – 063KV

63/2F DN20 Kv_{max} 2.8

In order to simplify the logistic and the installation at the building site, the valve is supplied with the maximum Kv, or flow rate, configuration (2.8 m³/h) on both sides.

Our fieldwork experience tells us heating and cooling flow rates are different because they are related to the project ΔT.

Very often, the heating flow rate is much smaller compare to the cooling one: the cooling ΔT is lower. Hence the choice to give a standard kit **063KV** together with the valve: this kit involves 4 couples of changeable discs made by PSU. The final user can select the suitable Kv for each side by changing the disc. The kit is included in the valve box.

The Kv value is written on the internal side of every disc. The installer, following the designer guidelines, picks adequate discs out for two sides.

This expedient ensures high flexibility and practicality.

JUST ONE PRODUCT CAN COVER UP TO 25 DIFFERENT COMBINATIONS

63/2F DN20 Kv_{max} 4

The valve **63/2F DN20 Kv_{max} 4** is supplied with the maximum Kv, or flow rate, configuration (4 m³/h) on both sides. A kit of two interchangeable rings allows to reduce the Kv value from 4 to 2.5.



Kv "Way 4"	Kv "Way 6"
2,8	2,8
2,8	2,1
2,8	1,6
2,8	1,0
2,8	0,7
2,1	2,8
2,1	2,1
2,1	1,6
2,1	1,0
2,1	0,7
1,6	2,8
1,6	2,1
1,6	1,6
1,6	1,0
1,6	0,7
1,0	2,8
1,0	2,1
1,0	1,6
1,0	1,0
1,0	0,7
0,7	2,8
0,7	2,1
0,7	1,6
0,7	1,0
0,7	0,7

Kv "Way 4"	Kv "Way 6"
4.0	4.0
4.0	2.5
2.5	4.0
2.5	2.5

It is strongly suggest to place the discs for Kv management on the return ways, namely on the ways number 4 and 6.

If any mistake is made throughout the installation of discs, the wrong one can be taken away using a two nole wrench (091SOS), like the picture beside.



PRESSURE DROP DIAGRAM

The diagram shows pressure losses of one side of 63/2F valve according to the chosen Kv value (or disc). The pressure drop behavior of the other side is equal.

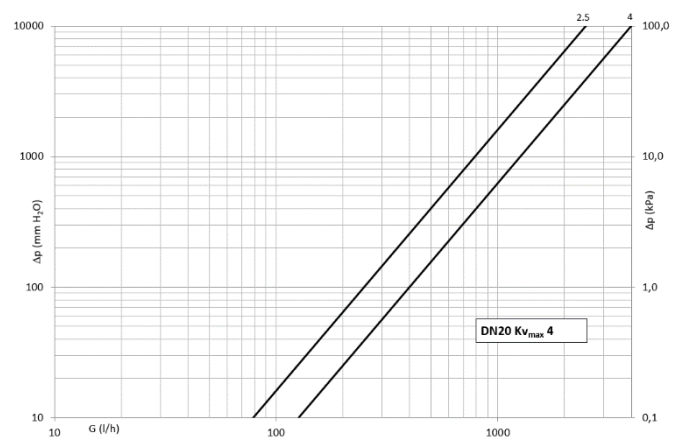
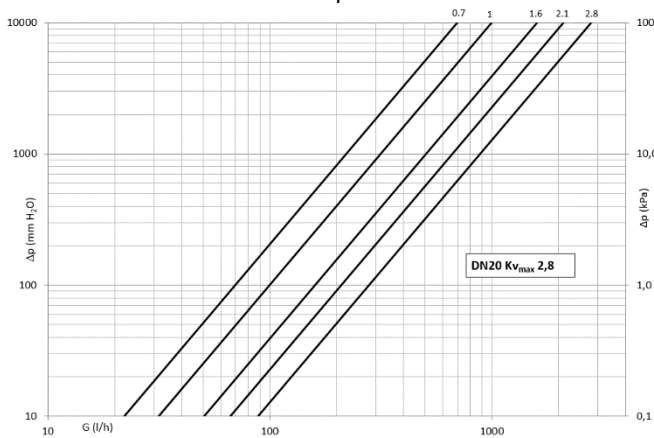

ACCESSORIES

FASTENING ANGLE – 063ZA

The Pettinaroli six-way valve 63/2F has an integral base with 4 threaded holes M4. The base can be easily fixed to a specific angle (item 063ZA). In this way the Pettinaroli six-way valve 63/2F makes the installation easier.

The 63/2F valve can be fixed to walls and ceilings by means of that angle.

Angle installation is easy thanks to two buttonholes on the vertical side. The valve can be fixed on the horizontal part using the specific holes: suitable M4 screws are included in the angle packing.

In case of different installation, a threaded M8 hole, placed in the center of the integrated base, can be used.

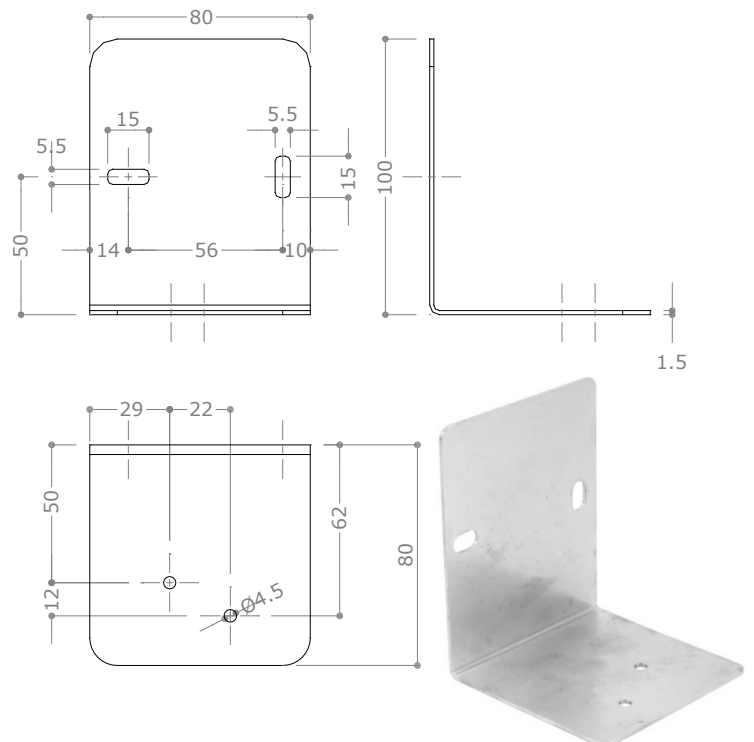
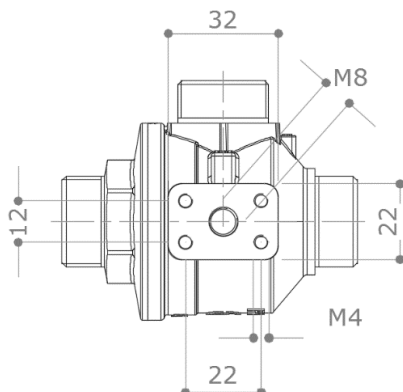

INSULATING CASE – 063GI

In order to ensure the thermal insulation of the Pettinaroli 63/2F, the insulating case 063GI is available as optional (to be purchased separately). The case can be installed even when the valve is already connected to pipes.



FITTINGS

The 3/4" M flat end connection is made as shown by the picture below. As shown by the second picture, be sure that end connections have a through-diameter smaller than 17 mm in order to hold the Kv selecting disc.

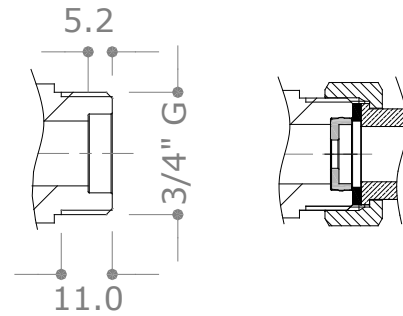

ACTUATOR FLANGE FEATURES

The picture beside shows the connection flange for the actuator. The valve 63/2F has an actuator connection compatible with F03 and F04 modes the EN ISO 5211 standard includes.

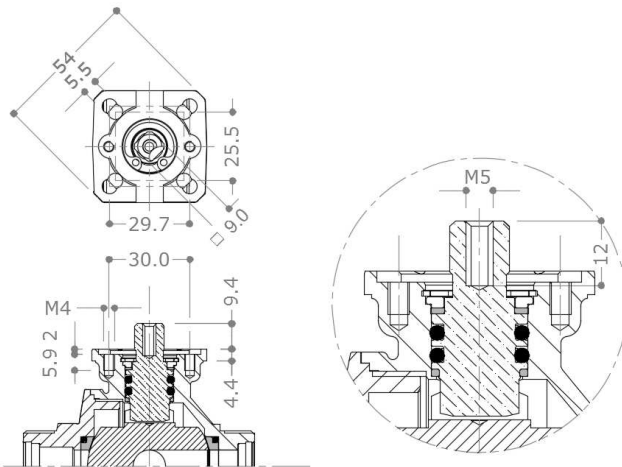

ASSEMBLY OF VALVE 63/2F WITH M63 AND FASTENING ANGLE 063ZA

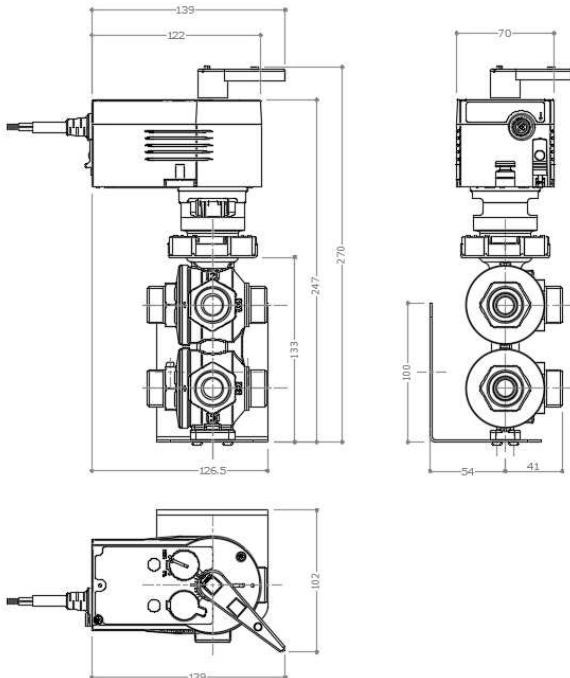

The procedure to assembly valve and actuator is reported on the technical datasheet/instruction of the M63 actuator.

CONTENTS OF THE PACKAGING

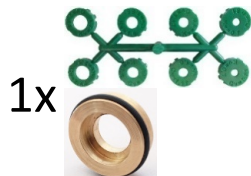

For Kv 2.8

For Kv 4

1x

PETTINAROLI
Art. 63 - 63/2
Date: _____
Project: _____
Location: _____
Contractor: _____

