

DESCRIPTION

VA7484



24 V electromotive proportional actuator with **feedback**, **valve stroke detection** system and **electrical fail-safe**. Max stroke 6.3 mm. Suitable for all axial Pettinaroli PICV (**91**, **92** and **93**). Connection M30x1.5, adapted to Pettinaroli standards through specific adaptors (not included – see below). Suitable also for 2-way, 3-way and 4-way control valves **662-663-664** (without extra adaptor)
 Not suitable for 91 manufactured before 2019 (see date code on PICV).

DIMENSIONS

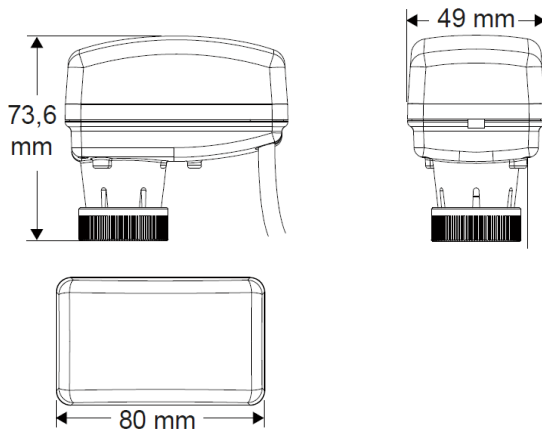

Dimensions in mm

TECHNICAL FEATURES

Type	Proportional	Running time	8 sec/mm
Supply voltage	24V AC/DC ±15% 50-60 Hz	Max fluid temperature	95°C
Control signal	0(2)-10VDC – 0(4)-20mA	Max storage temperature	-20° / + 65°C (@)
Feedback	0-10VDC ±5%	Max ambient temperature	0° / + 50° C (@)
Power consumption (acting)	2,5 VA / 1,5 W	Degree of protection	IP54/III
Power consumption (charging)	5 VA / 3 W	Weight	200 g
Input impedance (voltage control)	> 100 kΩ	Colour	White
Input impedance (current control)	500 Ω	Connection cable	4 x 0.35 mm ²
Charging time	150 s	Cable length	1.5 m
Max stroke	6,3 mm – stroke detection	Adaptor/ring	0A7010 : 91 and 92 ½" – ¾" 0A748X : 93 and 92 1" – 1 ¼"
Actuating force	160N	Noise level	<30 dB(A)

(@) non condensing

The 24 V electromotive actuator **VA7484** is widely employed to drive in proportional mode pressure independent control valves EVOVICV where electrical fail-safe is needed, controlling heating and cooling systems by means of BMS (Building Management System) or suitable room thermostat (managing and generating proportional signal 0-10V). Electrical connection is discussed in the following section. In order to choose the right adaptor, follow the scheme below:

- **91, 92 ½"** and **92 ¾"** with adaptor **0A7010** (not included)
- **93, 92 1"** and **92 1 ¼"** with adaptor **0A748X** (not included)

For further information refer to dedicated section on the EVOVICV technical manual and valves technical specifications.

APPROVALS



ELECTRICAL CONNECTION

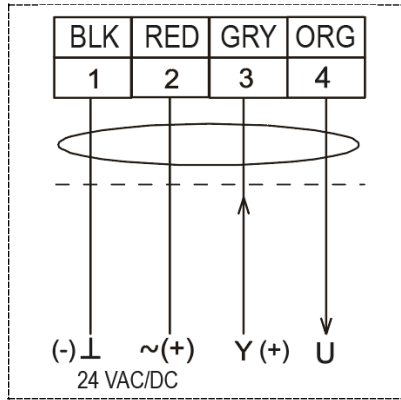

OPERATING STATUS INDICATION

The 24 V electromotive actuator **VA7484** has a RGB LED indicating its operating status as shown by the table below:

OFF		No power supply
RGB blinking		Not set
Green blinking		Moving to position
Green steady on		Position reached
Red blinking		Calibration cycle
Red fast blinking		Valve stem closing failure
Red steady on		4/20 mA or 2/10 Vdc lost
Blue blinking		Supercapacitor acting. Fail-safe on.
Blue fast blinking		End-of-life supercapacitor. Actuator replacement is suggested
Blue steady on		Supercapacitor charging

INSTALLATION

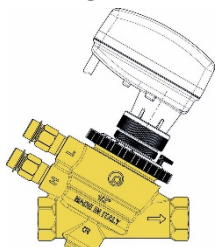

Fig.1

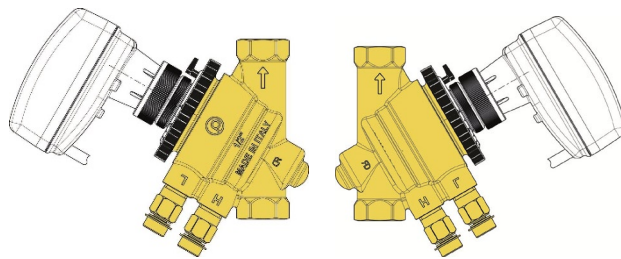

Fig.2

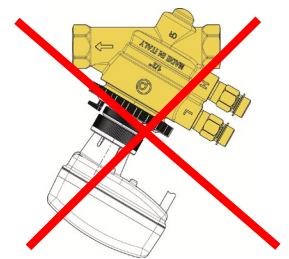

Fig.3

For electrical safety reasons the **VA7484** electromotive actuator has to be installed as shown by pictures 1 and 2. Please avoid any upside down installation as suggested by the picture 3. When disassembling the actuator from the valve, make sure the actuator stem is fully retracted and the fail-safe setting does not close the actuator when the power goes off (Electrical Fail-Safe Up or setting “safe unmounting”).

Do not power the actuator if not installed on the valve.

Tighten the connecting ring by hand only.

Keep 15 cm clear over the actuator to access it, if required.

SETTING

The actuator can be set only through the specific configurator **OC7484** (not included). The encoder is powered by 3 Alkaline batteries AA (not included). Please verify that the actuator is not powered during the setting procedure. Setting options are listed in the table below: default setting are written in bold.

Y (+) – Analog input	<i>Voltage</i>	<i>Current</i>
	0-10 VDC - default	
	2-10 VDC	0-20 mA
	0-5 VDC	4-20 mA
Action	Direct Action (DA)	Reverse Action (RA) - default
Curve	Linear (LIN) - default	Equal percentage (Eq%)
Electrical fail-safe	Electrical Fail-Safe Down (EFSU) - default ↓	Electrical Fail-Safe Up (EFSU) ↑

Actuator action according to digital input is detailed below

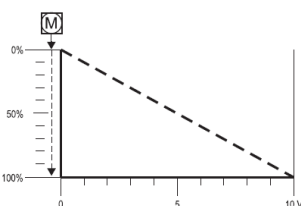

Direct Action DA – when the signal increases, the valve closes. 0 V valve open, 10 V valve closed

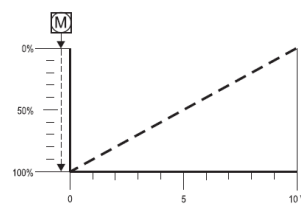

Reverse Action RA – when the signal increases, the valve opens. 0 V valve closed, 10 V valve open. *It is suitable for Pettinaroli valves*

Follow the procedure below to change actuator settings

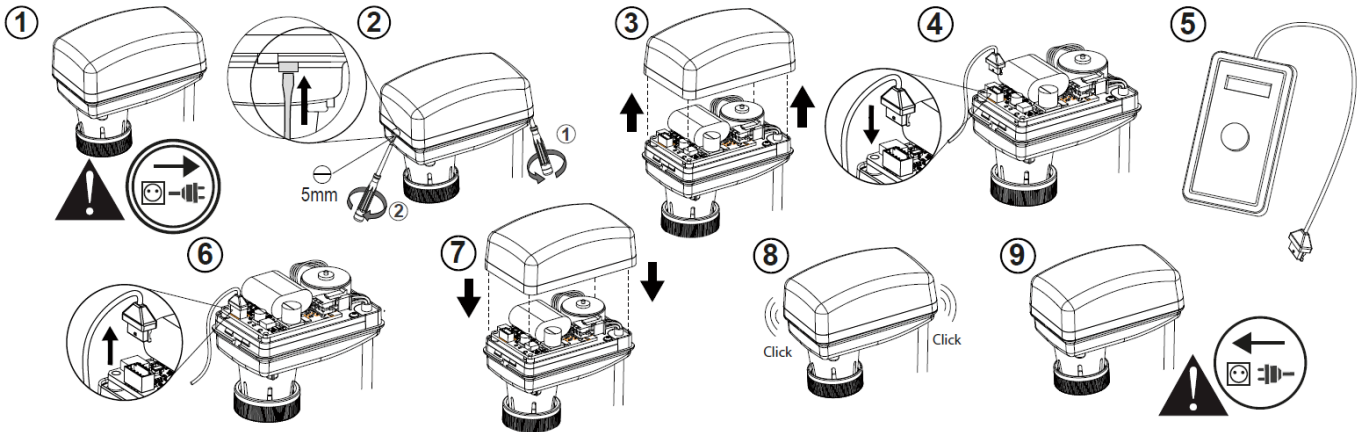

Change settings

Switching on the encoder

Connect the encoder to the dedicated port into the actuator and press the button for 2 sec. The device switches off in few seconds if not connected to the actuator. The actuator LED switches on.

The encoder has:

- A. LED status
- B. Display
- C. Button

Configuration

Use the knob to browse the encoder menu. Rotate clockwise to go ahead and counter-clockwise to go back. Keep pressed 2 sec to select and 4 sec to go back to previous level.

First level has following options:

1. **Load Configuration:** it shows on the display last configuration set of actuator (**ACTUATOR PARAMETER**) and the current settings of the encoder (**PRESET PARAMETER**).
2. **Set Configuration:** it shows all the selectable settings
3. **Safe Unmounting:** select this option to safely unmount the actuator. The stem will fully retract.

Configuration procedure

Select a specific setting to see all the available options. Once selected a setting, the encoder automatically goes back to the setting list. To go back the list avoiding any modification of the selected setting, press the button for 4 sec.

Settings are:

1. Control signal type

- I. Voltage
- II. Current

Control signal span

- a. 0-10 V (if setting 1 is "Voltage")
- b. 2-10 V (if setting 1 is "Voltage")
- c. 0-5 V (if setting 1 is "Voltage")
- d. 5-10 V (if setting 1 is "Voltage")
- e. 0-20 mA (if setting 1 is "Current")
- f. mA (if setting 1 is "Current")

3. Action type

- a. DA (Direct Action)
- b. RA (Reverse Action)

4. Curve type

- a. Linear
- b. Equal Percentage

5. Fail Safe action

- a. Electrical Fail Safe Up
- b. Electrical Fail Safe Down

To upload on the actuator the changes, go back to **SET CONFIG** and hold down for **5 sec.**; **DOWNLOAD PARAMETERS** will appear and, upon completion of the upload, **ACTUATOR UPDATED**. The status LED will light up green.

The new parameters are saved at the same time into the encoder: to modify other actuators with the same parameters, connect the configurator, move to **SET CONFIG** and hold down for **5 sec.** until **DOWNLOAD PARAMETERS** and **ACTUATOR UPDATED** appear.

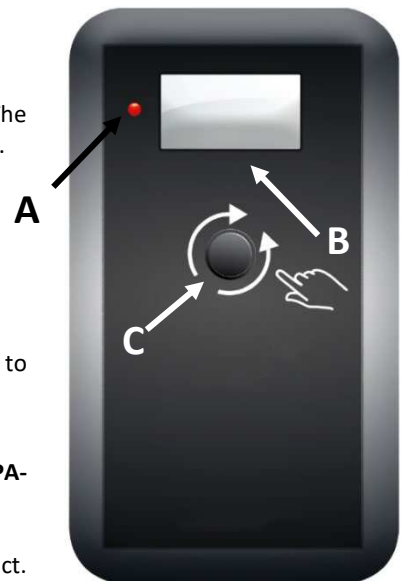

Safe Unmounting

Select this option to unmount the actuator if the electrical fail safe option is set on Down. Select the setting from the first level of the menu. Do not unmount the actuator on EFSD mode from the valve before having done the above procedure.