



DESCRIPTION

TB30 – TB30/2

Adjustable thermal balancing valve for sanitary hot water recirculation systems, made by lead free corrosion resistant brass conform to European (UBA-List & 4 MS) and USA (NSF) standard requirements. Equipped with Thermal element for automatic anti legionella treatment. Available with female x female and male x male connections. Available optionals: T39P/80 thermometer and reduction OTB02 ½ "M x (M10x1) to install a probe for remote monitoring of the water temperature.

Dimensions

TB30 – Female x Female x F

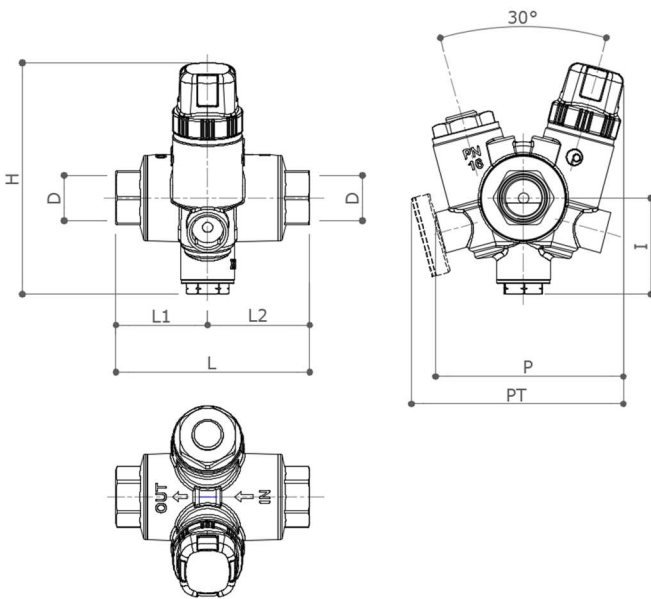

TB30/2 – Male x Male

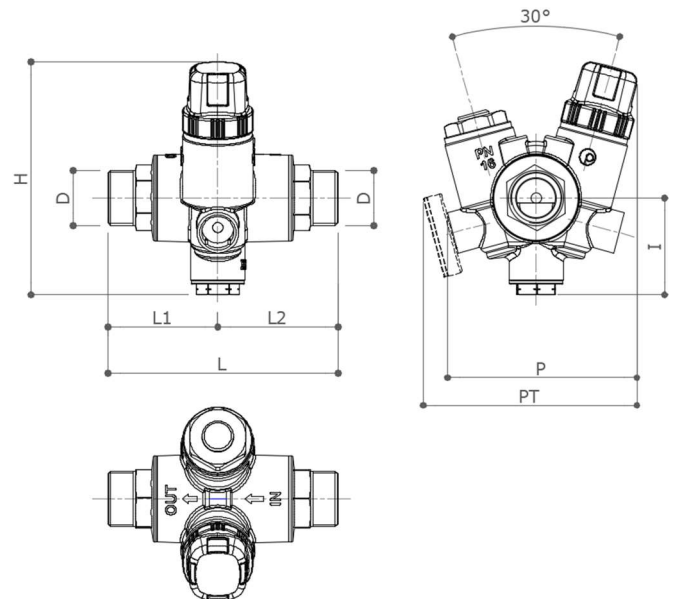

	D	L	L1	L2	H	I	P	PT	Weight (gr)
F x F	½" EN10226-1	93	44	49	112	46	91	102	950
Fx F	¾" EN10226-1	99	47	52	112	46	91	102	955
M X M	¾" M ISO228	110	52.5	57.5	112	46	91	102	950

Dimension mm - PT = with Optional thermometer (T39P/80 Optional) – drywell ½" M

MATERIALS

Body	CW511L (EN 12165)-CuZn38As-ASTM C27453	Protection Handwheel	PA66
Fitting	CW511L (EN 12165)-CuZn38As-ASTM C27453	Presetting Handwheel	ABS
Cap	CW511L (EN 12165)-CuZn38As-ASTM C27453	Spring	AISI302
O-ring	EPDM-X	Shutter	PSU

CHARACTERISTICS

Max working pressure	16 bar	Accuracy	±2°C
Maximum Differential Pressure	1 bar	Default Presetting	52°C
Max working temperature	90°C	K_{vmax}	1,8
Temperature setting range	35°- 60°C	K_{disnf} (by-passC)	1
Disinfection Temperature	70°C	K_{vmin} (T>75°C)	0,2

OPERATING PRINCIPLE

Thermostatic balancing valve TB30 – TB30/2 solve the balancing/temperature setting problems typical of sanitary hot water recirculation systems.

1. Balancing

Is often happens that the furthest users from the generator are penalized and consequently are supplied with domestic hot water that does not reach the minimum desired temperature value. These situations are perceived by users as a malfunction of the system itself.

The presence of a thermosensitive element (which is the heart of the valve itself) allows you to automatically balance the flow in the recirculation network depending on whether the water temperature exceeds the pre-set presetting value or not. Having established in advance an equal delivery temperature value for all the thermostatic balancing valves installed (for example 52 ° C), all the distribution risers will be supplied by hot domestic hot water at the desired temperature.

Thanks to the presence of a presetting device (selectable by removing the protective knob) the user has the possibility to set the desired temperature value ranging in the range 35 ° - 60 ° C (factory presetting 52 ° C). It is good practice that all the valves of the same system are set to the same value.

2. Anti-legionella disinfection/treatments

As required by health safety standards, anti-legionella treatments can be required to avoid proliferation of bacteria in hot potable water system. A common safety procedure is flushing the system with water at more than 70° C, temperature required to kill the bacteria. The TB30-TB30/2 valve is equipped with a second temperature sensor that allows circulation of water when the temperature is over 70°C that is the construction limit that cannot be modify by the end user.

The following diagram shows the variation of the flow rate (expressed as Kv) as a function of the temperature of the water flowing across the thermostatic balancing valve. Practically five distinct areas of operation can be identified.

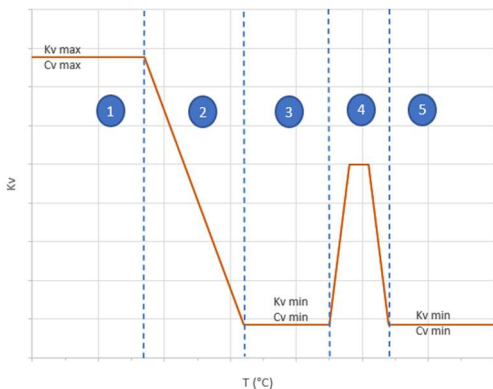

Working area 1 – **Maximum K_{vmax}** , $T_{water} \ll T_{presetting}$
 In this temperature range the valve is completely open and a spring is balancing the thermostatic element variations

Working area 2 – **variable K_v** , when T_{water} is reaching $T_{presetting}$.
 When the water temperature is reaching the selected temperature the thermostatic element is expanding and is closing the valve till the minimum design K_{vmin}

Working area 3 – **K_{vmin}** , $T_{water} \geq T_{presetting}$
 When the water temperature is more than the selected temperature the thermostatic element is keeping the valve in closed position and only the minimum flow rate is guarantee, K_{vmin}

Working area 4- **K_{disinf}** , $T_{water} \geq T_{disinf}$
 The second sensor allow the water to flow through the valve when the temperature reach the disinfection value (factory selected and not modifiable by end user).

Working area 5 – **K_{vmin}** , $T_{water} \geq T_{disinf}$
 When the water temperature is more than the disinfection point the flow rate is reduced to the mi minimum KV

The TB30 – TB30/2 are not a shut off valve, a minimum flow rate K_{vmin} .is guarantee.

THERMOWELL FOR TEMPERATURE SENSOR

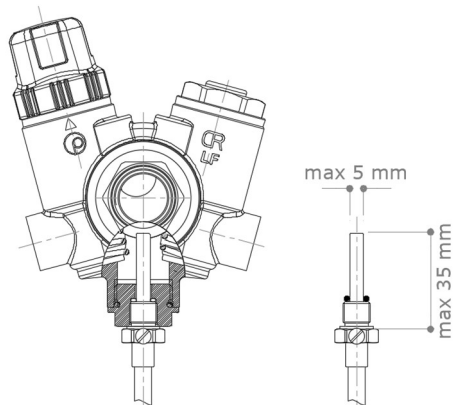

TB30 and TB30/2 has a drywell (1/2") that could be used (through an optional reduction OTB02 ½ "M x (M10x1)), to install a probe for remote monitoring of the water temperature.

Suggested size of the probe should be followed to select the right dimension thermowell diameter/length and sensors.

The thermowell and the sensor allow the remote control and monitoring of the temperature of the water during normal operation and disinfection operations.

PRESETTING OPERATION.

TB30 – TB30/2 valves has factory presetting at 52°C (corresponding to position ▼ on the selector), the user can change the presetting by following the instructions:

1. Remove the handwheel protection cap
2. Turn the selector to the target position



This is a simple but important operation for the proper functioning of the system. It is always advisable to preset the system valves at a temperature value greater than 3-5 °C compared to the temperature actually desired on the most penalized users. This way, the overall pressure losses will be limited to the advantage of choosing the circulator dedicated to the recirculation network.

EXAMPLE OF CALCULATION/DESIGN

The correct sizing of the system and the evaluation of the impact that each component can have in the fluid dynamics of the same is always the root of good operation. It is therefore essential to evaluate the incidence of the thermostatic balancing valve in the overall calculation of the pressure drops for the choice of the type of needed circulator. An explanatory practical example is given below.

Consider a 3-storey residential complex characterized by the presence of 5 risers for the distribution of sanitary water, each of it consists of the Hot Water (ACS) riser, the Cold Water riser (AFs) and the Recirculation R.

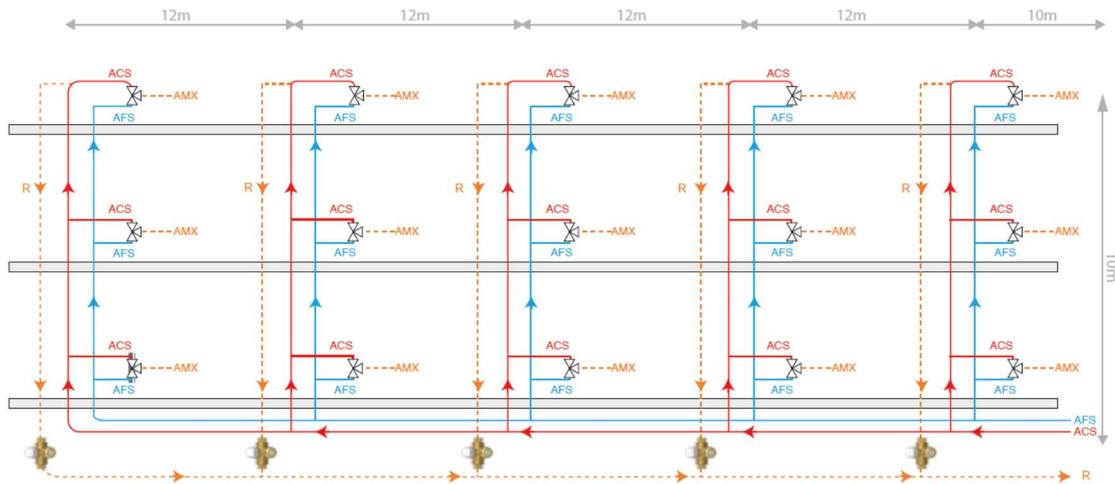

A. STANDARD WORKING OPERATION

To guarantee to the most penalized thermostatic balancing valve a flow of water whose temperature (T_{SF}) is not lower than 5 °C with respect to the outlet of the generator (T_G), each flow rate can be calculated considering the heat losses along the entire line from the generator to the last thermal balancing valve.

Hypothesis:

1. ACS temperature $T_G = 57^\circ\text{C}$
2. Valve selected temperature TB 52°C (pos. ▼ - default)
3. Heat losses of the pipes. $q_l = 10 \text{ W/m}$
4. Maximum temperature drops through the system, risers and horizontal manifold. $\Delta T = T_G - T_{SF} \leq 5\text{K}$

For each riser and for each stretch of horizontal manifold, the extent of the heat losses are evaluated and, based on that, the amount of water flowrate to ensure a $\Delta T = 5\text{K}$ is determined.

Circuit n°	Total vertical length (ACS + R) (m)	Vertical risers er Heat losses (W)	Total horizontal manifold length (m)	Horizontal manifold heat losses (W)	Total heat loss for every complete circuit (W)	Total heat loss (W)	Riser flow rate (l/h)	Total flow rate (l/h)
1	20	200	10	100	300	1580	37	272
2	20	200	12	120	320	1280	41	235
3	20	200	12	120	320	960	46	195
4	20	200	12	120	320	640	57	148
5	20	200	12	120	320	320	91	91

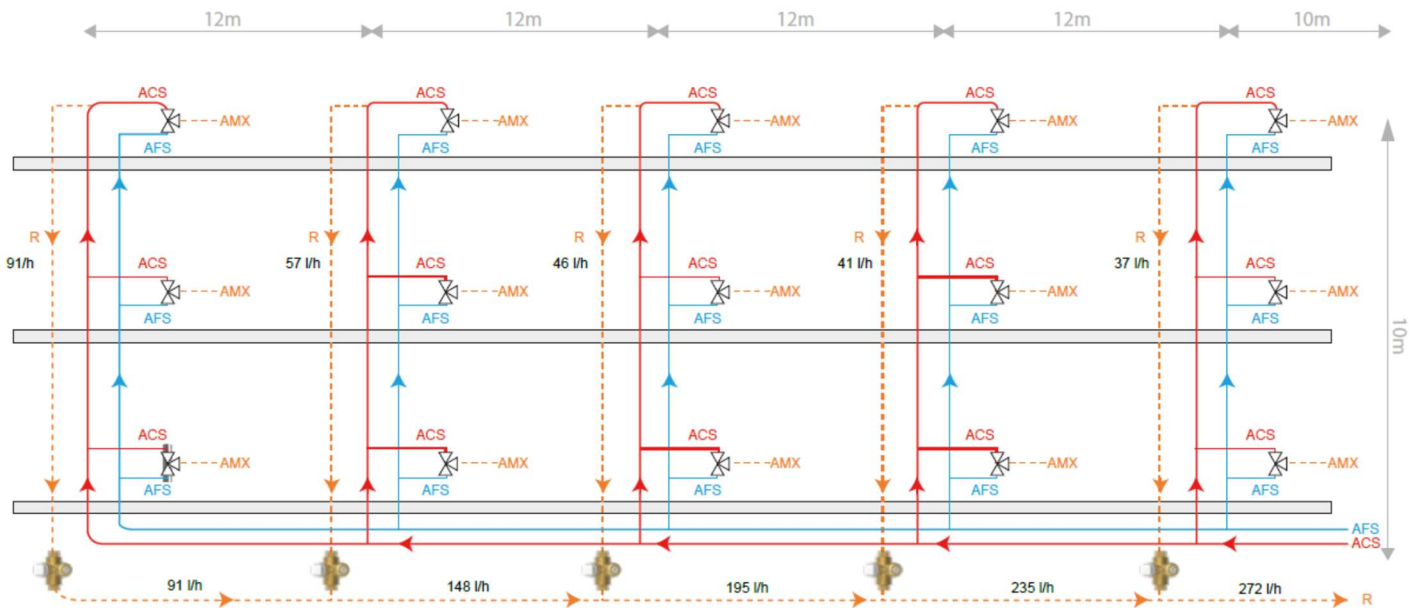

Based on the flow rate value calculated for the most penalized riser by heat losses (Column n ° 5 - 91 l / h), the available water temperature (TG = 57 ° C) and the maximum temperature jump (5K) allowed as an initial hypothesis and the preset value, the Kv and the relative pressure drop at 52 ° C will be evaluated (with an excellent approximation corresponding to the position ▼ on the valve). Through the characteristic diagram of the TB20 thermostatic balancing valve (or from the relative table values shown below for ease of reference) the Kv value settles at 0.45

°T	1	2	3	4	▼	5	6
°C	Kv	Kv	Kv	Kv	Kv	Kv	Kv
20,0	1,82	1,82	1,82	1,82	1,82	1,82	1,82
22,5	1,82	1,82	1,82	1,82	1,82	1,82	1,82
25,0	1,78	1,82	1,82	1,82	1,82	1,82	1,82
27,5	1,45	1,82	1,82	1,82	1,82	1,82	1,82
30,0	1	1,78	1,82	1,82	1,82	1,82	1,82
32,5	0,65	1,5	1,82	1,82	1,82	1,82	1,82
35,0	0,45	1,12	1,82	1,82	1,82	1,82	1,82
37,5	0,3	0,7	1,7	1,82	1,82	1,82	1,82
40,0	0,28	0,45	1,3	1,82	1,82	1,82	1,82
42,5	0,27	0,31	0,9	1,78	1,82	1,82	1,82
45,0	0,25	0,25	0,5	1,45	1,75	1,82	1,82
47,5	0,24	0,24	0,35	0,85	1,4	1,79	1,82
50,0	0,23	0,23	0,28	0,48	0,8	1,5	1,82
52,5	0,22	0,22	0,22	0,35	0,45	0,85	1,72
55,0	0,21	0,21	0,21	0,28	0,32	0,45	1,35
57,5	0,205	0,205	0,205	0,26	0,25	0,33	0,7
60,0	0,2	0,2	0,2	0,24	0,2	0,28	0,45
62,5	0,2	0,2	0,2	0,22	0,2	0,22	0,32
65,0	0,2	0,2	0,2	0,21	0,2	0,2	0,24

$$\Delta P = \left(\frac{Q}{100 \times Kv} \right)^2 = \left(\frac{91}{100 \times 0,45} \right)^2 = 4.1 \text{ kPa}$$

At this pressure drop we must add:

1. Headers and risers' pressure drops.
2. Recirculation circuit pressure drops.

The total pressure drop together with the flow value has to be used to select the right pump.

B. DISINFECTION

By using the TB30 – TB30/2 thermostatic valve on all the risers an automatic anti-legionella treatment is possible on the complete system in one operation, by using TB50 thermostatic balancing valve (controlled remotely) it is possible to select the riser individually and operate the disinfection in selected part of the system only, the same operation can be done by using actuated valves and/or manual operated valves

Following an example of how the operation is performed on a system with 5 risers

Hypothesis:

1. Disinfection Water temperature $T_G = 75^\circ\text{C}$
2. Factory selected disinfection temperature 70°C
3. Heat losses of the pipes. $q_l = 10 \text{ W/m}$
4. Maximum temperature drops through the system, risers and headers. $\Delta T = T_G - T_{SF} \leq 5\text{K}$

For each riser and for each stretch of horizontal manifold, the extent of the heat losses are evaluated and, based on that, the amount of water flowrate to ensure a $\Delta T = 5\text{K}$ is determined.

Circuit n°	Total vertical length (ACS + R) (m)	Vertical risers er Heat loss (W)	Total horizontal Headers length (m)	Horizontal Headers heat loss (W)	Total heat loss for every complete circuit (W)	Total heat loss (W)	Riser flow rate (l/h)	Total flow rate (l/h)
1	20	270	10	135	405	2133	50	367
2	20	270	12	162	432	1728	55	317
3	20	270	12	162	432	1296	63	263
4	20	270	12	162	432	8640	77	200
5	20	270	12	162	432	432	123	123

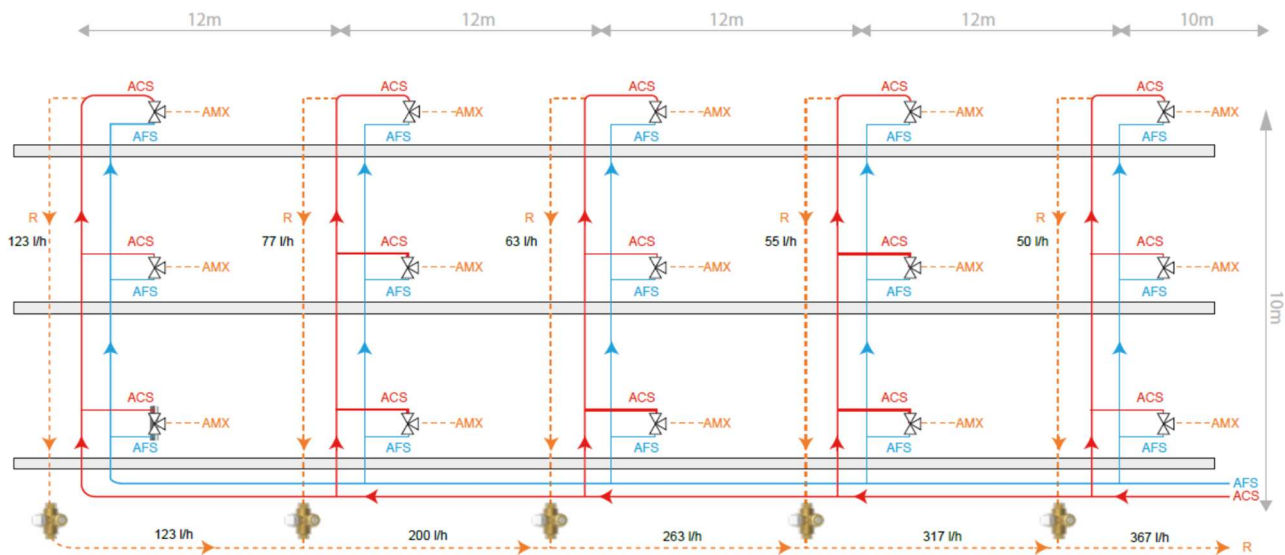

Once we have the flow rate for the least circuit (riser n° 5 – 123 l/h), based on the hypothesis of water temperature (75 °C) and maximum delta T allowed (5K) it is possible to proceed with evaluation of K_v and pressure drop at 70°C
 By using the TB30-TB30/2 valve characteristic diagram or the following table it is possible to have the valve pressure drop

°T	1	2	3	4	5	6
°C	K_v	K_v	K_v	K_v	K_v	K_v
20,0	1,82	1,82	1,82	1,82	1,82	1,82
22,5	1,82	1,82	1,82	1,82	1,82	1,82
25,0	1,78	1,82	1,82	1,82	1,82	1,82
27,5	1,45	1,82	1,82	1,82	1,82	1,82
30,0	1	1,78	1,82	1,82	1,82	1,82
32,5	0,65	1,5	1,82	1,82	1,82	1,82
35,0	0,45	1,12	1,82	1,82	1,82	1,82
37,5	0,3	0,7	1,7	1,82	1,82	1,82
40,0	0,28	0,45	1,3	1,82	1,82	1,82
42,5	0,27	0,31	0,9	1,78	1,82	1,82
45,0	0,25	0,25	0,5	1,45	1,75	1,82
47,5	0,24	0,24	0,35	0,85	1,4	1,79
50,0	0,23	0,23	0,28	0,48	0,8	1,5
52,5	0,22	0,22	0,22	0,35	0,45	0,85
55,0	0,21	0,21	0,21	0,28	0,32	0,45
57,5	0,205	0,205	0,205	0,26	0,25	0,33
60,0	0,2	0,2	0,2	0,24	0,2	0,28
62,5	0,2	0,2	0,2	0,22	0,2	0,22
65,0	0,2	0,2	0,2	0,21	0,2	0,2
67,5			0,5			
70,0			1			
72,5			0,8			
75,0			0,25			
77,5			0,22			
80,0			0,2			
82,5			0,2			
85,0			0,2			

$$\Delta P = \left(\frac{Q}{100 \times K_v} \right)^2 = \left(\frac{123}{100 \times 1} \right)^2 = 1,5 \text{ kPa}$$

At this pressure drop we must add:

1. Headers and risers' pressure drops.
2. Recirculation circuit pressure drops.

The total pressure drop together with the flow value (367 l/h) has to be used to select the right pump.

C. DISINFECTION BY USE OF REMOTE CONTROL

In case the system is equipped with remote control to control the opening of each riser by using motorized valve, it is possible to plan the disinfection operation riser by riser.
 The hypothesis are the same as the previous method but the calculations take inconsideration only the least riser.

Circuit n°	Total vertical length (ACS + R) (m)	Vertical risers er Heat loss (W)	Total horizontal Headers length (m)	Horizontal Headers heat loss (W)	Total heat loss for every complete circuit (W)	Total heat loss (W)	Riser flow rate (l/h)
1	20	270	10	135		1053	
2	20	270	12	162		1053	
3	20	270	12	162		1053	
4	20	270	12	162		1053	
5	20	270	12	162	1053	1053	181

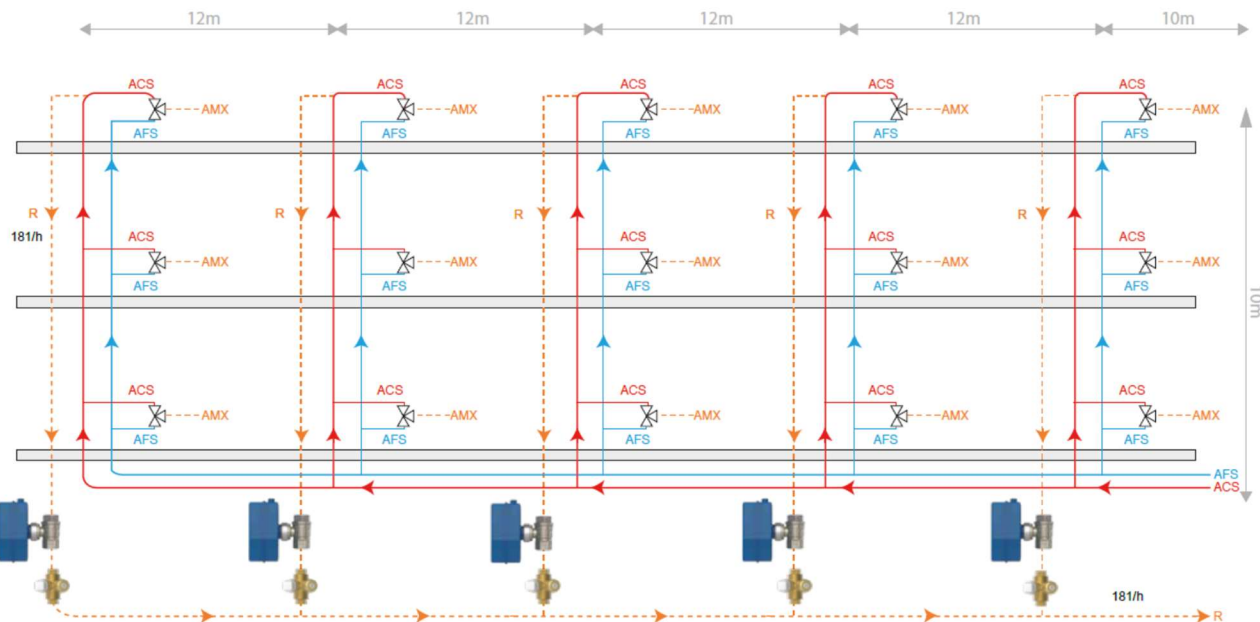

Ones we have the flow rate for the least circuit (riser n° 5 – 181 l/h), based on the hypothesis of water temperature (75 °C) and maximum delta T allowed (5K) it is possible to proceed with evaluation of Kv and pressure drop at 70°C

*T °C	1	2	3	4	5	6
20,0	1,82	1,82	1,82	1,82	1,82	1,82
22,5	1,82	1,82	1,82	1,82	1,82	1,82
25,0	1,78	1,82	1,82	1,82	1,82	1,82
27,5	1,45	1,82	1,82	1,82	1,82	1,82
30,0	1	1,78	1,82	1,82	1,82	1,82
32,5	0,65	1,5	1,82	1,82	1,82	1,82
35,0	0,45	1,12	1,82	1,82	1,82	1,82
37,5	0,3	0,7	1,7	1,82	1,82	1,82
40,0	0,28	0,45	1,3	1,82	1,82	1,82
42,5	0,27	0,31	0,9	1,78	1,82	1,82
45,0	0,25	0,25	0,5	1,45	1,75	1,82
47,5	0,24	0,24	0,35	0,85	1,4	1,79
50,0	0,23	0,23	0,28	0,48	0,8	1,5
52,5	0,22	0,22	0,22	0,35	0,45	0,85
55,0	0,21	0,21	0,21	0,28	0,32	0,45
57,5	0,205	0,205	0,205	0,26	0,25	0,33
60,0	0,2	0,2	0,2	0,24	0,2	0,28
62,5	0,2	0,2	0,2	0,22	0,2	0,22
65,0	0,2	0,2	0,2	0,21	0,2	0,24
67,5				0,5		
70,0				1		
72,5				0,8		
75,0				0,25		
77,5				0,22		
80,0				0,2		
82,5				0,2		
85,0				0,2		



By using the TB30-tb30/2 valve characteristic diagram or the following table it is possible to have the valve pressure drop

$$\Delta P = \left(\frac{Q}{100 \times Kv} \right)^2 = \left(\frac{181}{100 \times 1} \right)^2 = 3,3 \text{ kPa}$$

At this pressure drop we must add:

1. Headers and risers' pressure drops.
2. Recirculation circuit pressure drops.

The total pressure drop together with the flow value (181 l/h) has to be used to select the right pump.

This type of systems allows to perform a disinfection operation by using a limited flow rate.

Kv vs. TEMPERATURES CHART

Below is the characteristic operating diagram of the TB30 and TB30/2 valves which shows the K_v value as a function of the temperature of the water passing through the valve and the presetting value selected

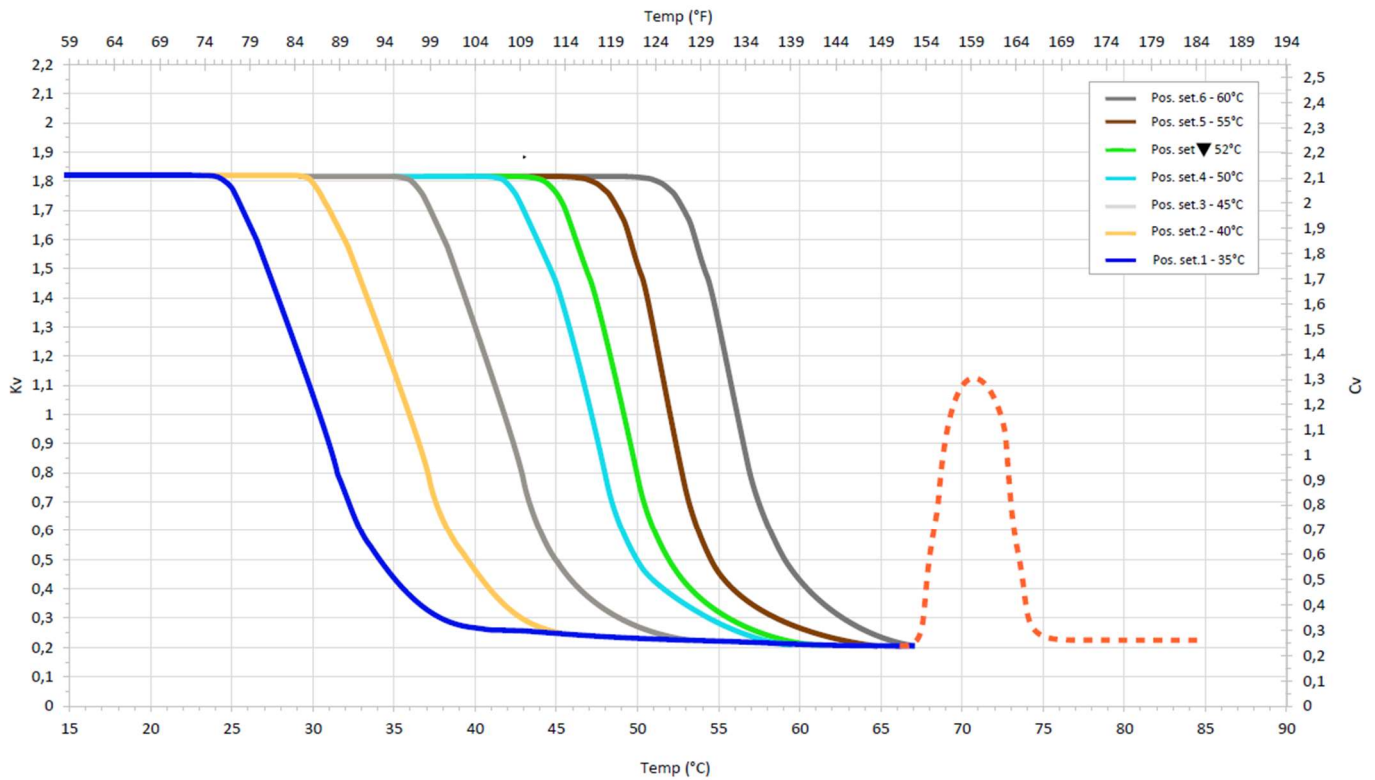

INSTALLATION.

The TB30-TB30/2 Valve can be installed both at the top or bottom at the of the riser, with the following considerations:

- Accessible
- At least 0.5 meters from the headers
- With the right orientation considering flow rate direction

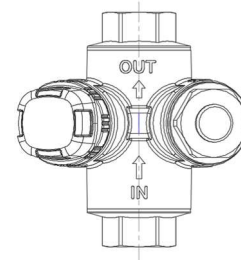

The TB30-TB30/2 thermostatic balancing valve can be installed without any particular precautions regarding the position; it can be installed both vertically and horizontally and possibly also upside-down. Not being equipped with built-in filters or electrical/electronic elements, there is no risk.

As for all types of balancing valves (whether they are intended for air conditioning systems or as in this case for sanitary distribution systems), in order to avoid operating problems, it is always recommended to install means of suitable filtering capacity in the systems. such as the 51F - FILTERBALL ball valves with incorporated strainer.

ACCESSORIES

T39P/80

Double scale 0-80°C / 32°-176°F



OTB02

Adaptor/reduction OTB02 ½ "M x (M10x1) for probe to monitoring the water temperature.



TB100CK

Union Ball valve DN20 with integrated check valve to be used downstream the TB30/2.

Sizes available:

½ F x ¾" F swivel nut

¾" F x ¾" F swivel nut



TB100

Union Ball valve DN20 to be used upstream the TB30/2.

Sizes available:

½ F x ¾" F swivel nut

¾" F x ¾" F swivel nut

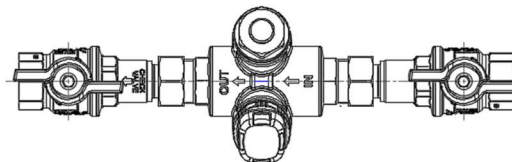
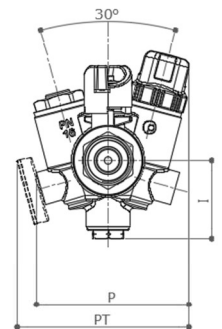
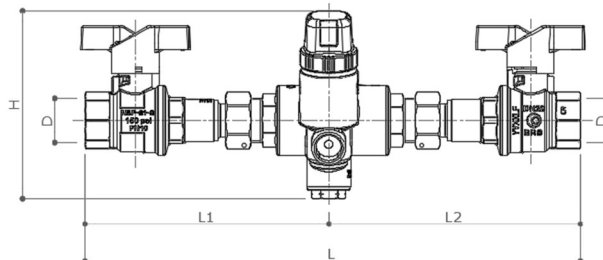
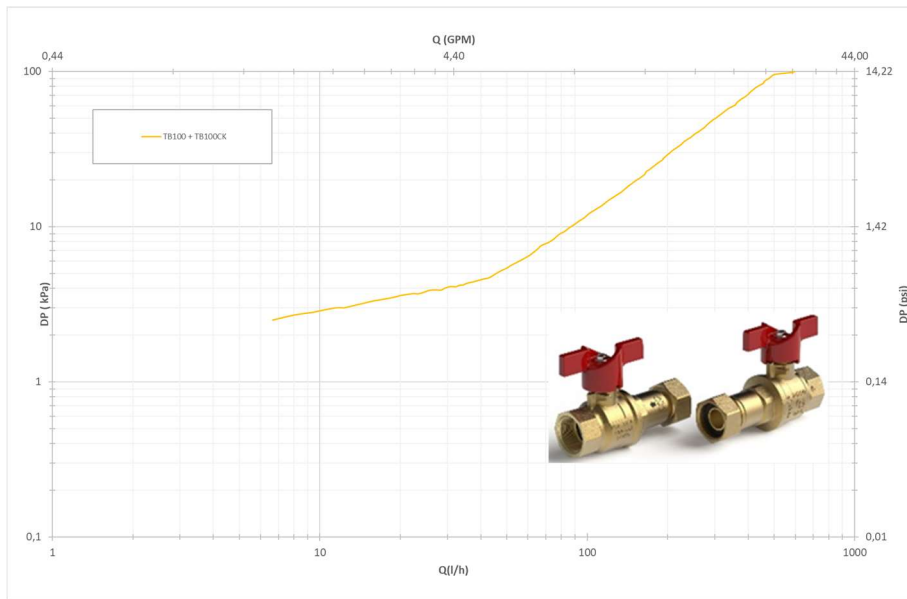

	D	L	L1	L2	H	I	P	PT
F x F	½" EN10226-1	293	144	149	112	46	91	102
F x F	¾" EN10226-1	293	144	149	112	46	91	102

OTBOOCK

Check valve MxF to be used downstream the TB30.

Body: CW511L

Check Valve: Noryl GF

Sizes Available:

½ F x ½”M

¾”F x ¾”M

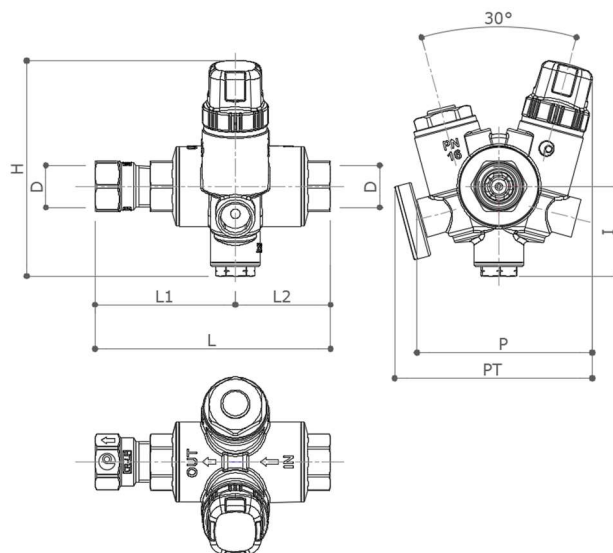
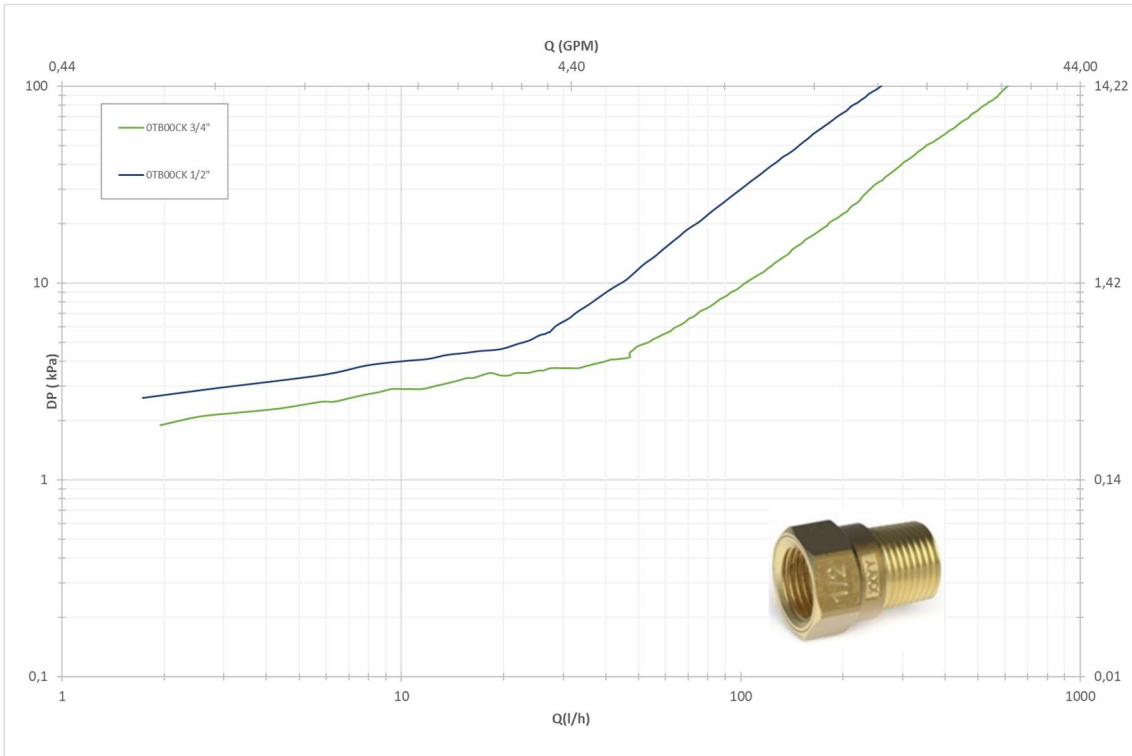

	D	L	L1	L2	H	I	P	PT
F x F ½"	EN10226-1	122	73	49	112	46	91	102
F x F ¾"	EN10226-1	138	86	52	112	46	91	102