

SB1N



EN Description

Variable orifice static balancing valve for HVAC (heating and cooling). Through this valve the pre-setting and flow balancing in branch segments or in the general circuit can be carried out. It allows to set the correct flow rate along the specific stretch to improve comfort and optimize energy consumption. In addition, the valve allows measurement (with a special tool) and flow rate shut-off. It can be installed indifferently on the flow or on the return ways.

EN Valve features

The SB1N valve offers the following functions:

- Body made of iron;
- Conform to European Directive 2014/68/EU PED (ex 97/23/CE);
- Face to face (FTF) according to EN 558-1 series 1;
- Flanges according to EN1092-2 PN16 (ANSI version available);
- Pressure test according to EN12266-1, tests P11 and P12;
- Memorying of pre-setting position;
- Internal and external coating with epoxidic high temperature resistan water varnish;
- Continuous ajustement for the exact control of the flow rate and the pressure drop;
- Self-sealing pressure port to measure the pressure and the temperature;
- Shutter with EPDM or FKM joint (depending on the model);
- Stem with double sealing.

Model	T min [°C]	T max [°C]	P max [bar]	Notes	Allowed medium
DN65-DN80-DN100-DN125-DN150-DN200	-10	120	16	Conform to PED - cat. 1	Water / Water+ glycol (max 50%)
DN250-DN300	-10	110	16	Conform to PED - art. 4 par. 3	



EN Dimensions and weight

The following tables collect the main dimensions, expressed in **mm**, and the weight, expressed in **kg**, for the various valve models available:

DN65-DN80-DN100-DN125-DN150

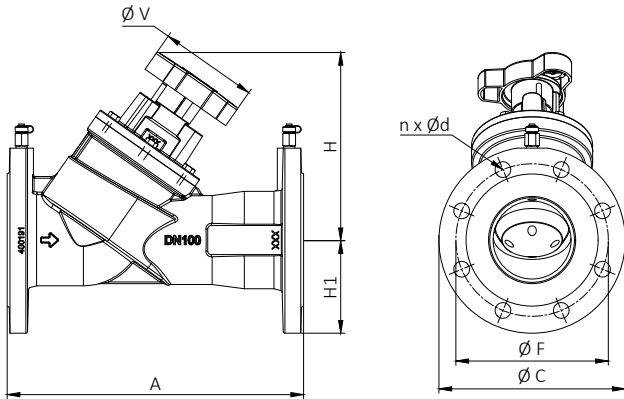

DN	65	80	100	125	150	Notes
A	290	310	350	400	480	EN 558-1/1
H	195	212	228	251	287	
H1	92.5	100	110	125	142.5	
V	128	128	128	128	128	Lobed handwheel
C	185	200	220	250	285	
F	145	160	180	210	240	EN 1092 PN16
n x Ød	4 x 18	8 x 18	8 x 18	8 x 18	8 x 22	
Weight	12.6	15.6	21.3	30	43.5	

DN200

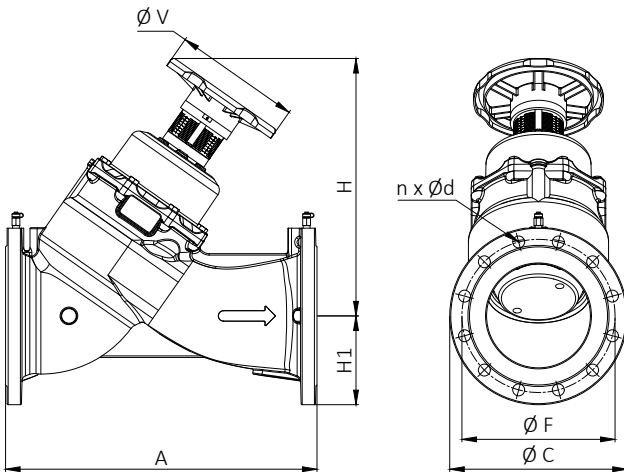

DN	200	Notes
A	600	EN 558-1/1
H	500	
H1	170	
V	200	Spoked handwheel
C	340	
F	295	EN 1092 PN16
n x Ød	12 x 22	
Weight	84	

DN250-DN300

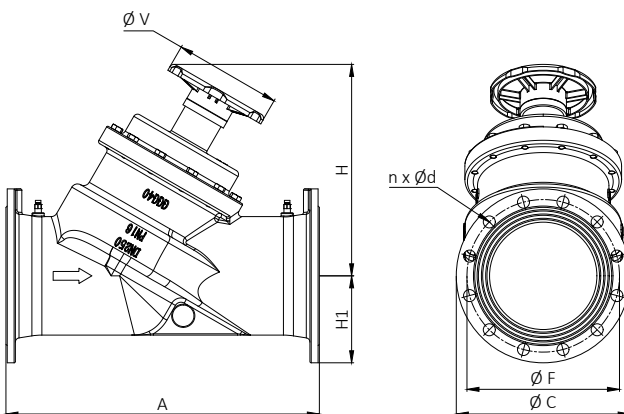

DN	250	300	Notes
A	730	850	EN 558-1/1
H	460	600	
H1	202.5	230	
V	250	250	Spoked handwheel
C	405	460	
F	355	410	EN 1092 PN16
n x Ød	12 x 28	12 x 28	
Weight	146	200	

EN Materials

The materials used for each type of valve are shown in the table below:

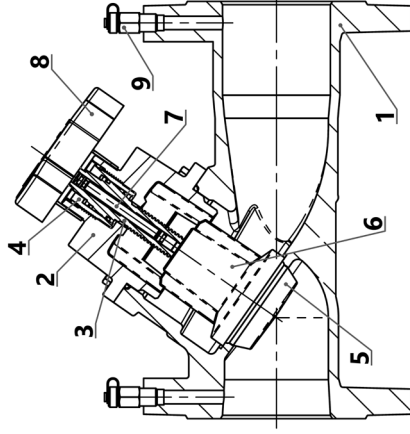

	DN65-DN80-DN100-DN125-DN150	DN200	DN250-DN300
1 Body	Cast iron EN GJL 250	Cast iron EN GJL 250	Ductile iron EN GJS 400-15
2 Upper cover	Cast iron EN GJL 250	Cast iron EN GJL 250	Ductile iron EN GJS 400-15
3 Stem	CW614N CuZn39Pb3	CW614N CuZn39Pb3	CW614N CuZn39Pb3
4 Ring nut	CW614N CuZn39Pb3	CW614N CuZn39Pb3	-
5 Joint	EPDM	EPDM	FKM
6 Shutter	Technopolymer	Technopolymer	Ductile iron EN GJS 400-15
7 Limiting screw	CW614N CuZn39Pb3	CW614N CuZn39Pb3	CW614N CuZn39Pb3
8 Handwheel	Polyamide	Steel with epoxidic paint	Nylon
9 Pressure ports	CW614N CuZn39Pb3	CW614N CuZn39Pb3	CW614N CuZn39Pb3
- O-ring	EPDM	EPDM	FKM
- Screws	AISI 304	AISI 304	Galvanized carbon steel

EN Installation

Before installation check that:

- the pipe system is clean;
- the valve is clean and undamaged;
- flanges sealing surfaces are clean and undamaged.

The valve is unidirectional. Respect the flow direction indicated by the arrow on the body; use suitable gaskets and check that they are correctly centred.

Install the valve in such a way that there's enough space for operations such as:

1. Regulation of the valve.
2. Position indicator reading.
3. Regulation of the memory stop (more info in "setting" chapter).

Avoid any inclination, twisting misalignment of the piping because they can cause improper stresses on the valve once installed. Pay attention to water hammers as they might cause damage and breakage. Tighten the bolts crosswise.

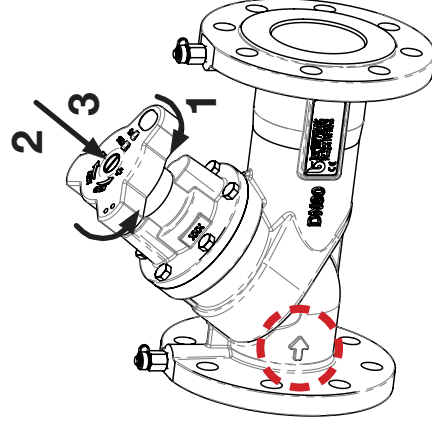

DN65-DN80-DN100-DN125-DN150

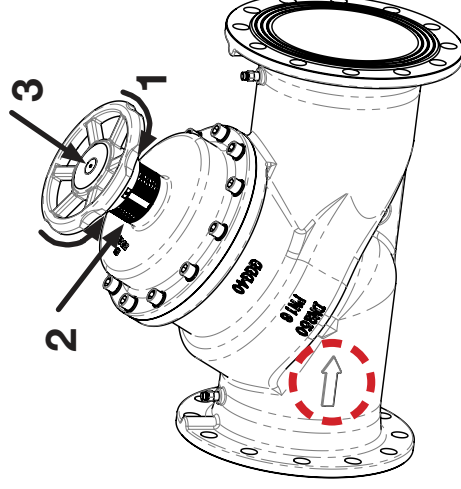

DN200-DN250-DN300

EN Pipeline design

In order to guarantee that temperature and pressure limits are not exceeded, system should be fitted with safety thermostats and pressure switches. Observe the minimum distances between valve and other system components as shown in the table below:

Component	Distance upstream	Distance downstream
Pump	10 x DN	-
Bends - tees	5 x DN	2 x DN

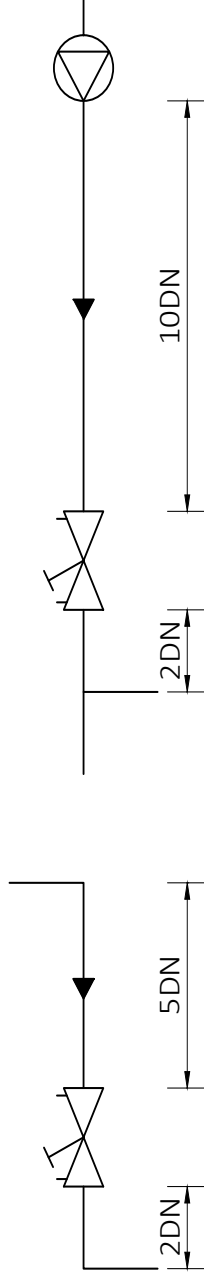

EN Commissioning

It is suggested to flush the system with the valve totally opened. If a system pressure test is required, the maximum allowable pressure PS can be exceeded up to a maximum value of 24 bar. The test must be carried out at room temperature and with the valve in fully open position.

EN Conversion of units of measure

The following table reports the multiplication coefficients that can be used to convert the pressure and flow rate values into the most suitable units of measurement for the case:

From	Multiply by	To get
kPa	0.01	bar
kPa	0.1097	mH ₂ O
kPa	0.145	psi
m ³ /h	0.2778	l/s
m ³ /h	16.6667	l/min
m ³ /h	264.172	gph (US)
m ³ /h	4.402	gpm (US)
l/min	0.2642	gpm (US)
To get	Divide by	From

EN Setting

Valve position can be read from the graduated scales which show the basic setting (number of complete turns) and the fine setting (1/10 of turn). Intermediate positions can be adjusted continuously. Pre-setting position can be retrieved by the mean of an adjustable travel stop.

For sizes up to DN150, the adjustment handwheel has a lobe structure (fig. a); from DN200 it is a spoked handwheel (fig. b).

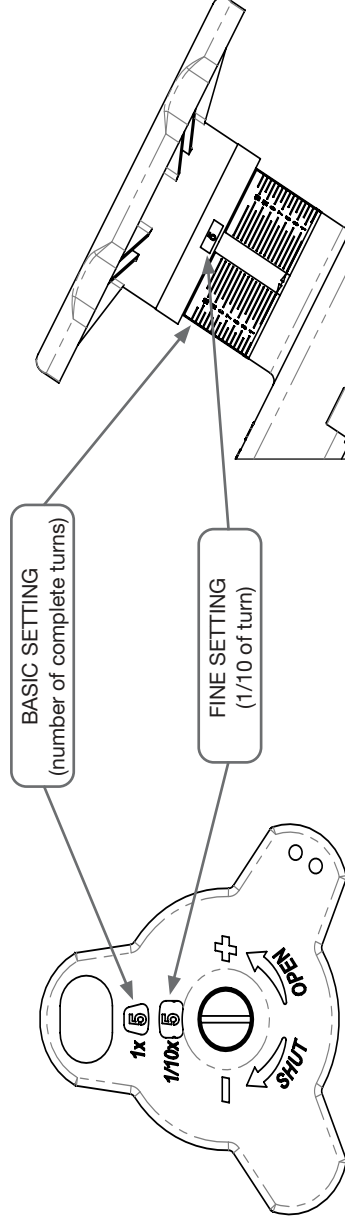

Fig. a

Fig. b

Given the flow rate, the required pressure drop needed for balancing and obtained the setting position of the valve from the setting diagram, proceed as follows to set it:

1. Fully close the valve.
2. Open the valve to the calculated value, read on the scales.



3. Remove the upper screw.
4. With a flat head screwdriver turn clockwise the inner stop stem until it stops.
5. Screw the upper screw back on. Now the valve can be closed, but the set opening position can not be overrun.

To check the setting position:

1. Fully close the valve.
2. Open the valve to the stop position. The pre-setting position is shown by the graduated scales.

EN Flow rate tolerance

The flow rate regulation accuracy is expressed as a percentage error ϵ with respect to the pre-set flow rate value. The graph below shows the trend of ϵ as the valve opening level varies.

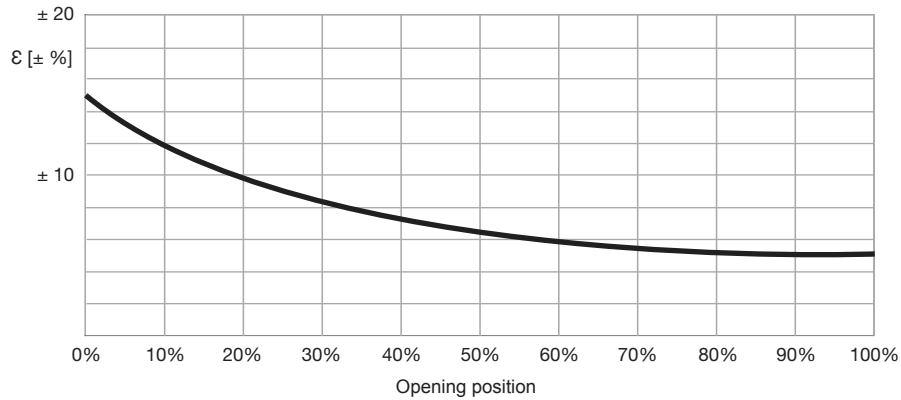

EN Differential pressure adjustment factors

All the diagrams are suitable for pure water. If an antifreeze is added to water, the viscosity and the specific density change and this causes a variation of the pressure drop being flow rate the same, especially at low temperature. Given for the water-antifreeze mix the required pressure drop for balancing, in order to use the regulation diagram the adjusted pressure drop must be calculated for pure water: the required pressure drop has to be divided by the adjustment factor. The adjustment factor is given by the following formula:

$$f = C \cdot x + b$$

where:

- f = adjustment factor;
- x = glycol percentage;
- C, b = constants depending on temperature and type of glycol used (see table below).

Temperature [°C]	Ethylene glycol		Propylene glycol	
	C	b	C	b
80	0.0034	0.850	0.0030	0.850
65	0.0037	0.880	0.0040	0.880
50	0.0043	0.911	0.0050	0.911
35	0.0047	0.951	0.0061	0.951
20	0.0053	1.000	0.0069	1.000
5	0.0061	1.055	0.0073	1.055

CALCULATION EXAMPLE

Let's have a DN65 valve which must guarantee a pressure drop of 15 kPa with a circulating flow rate of 4,2 m³/h. The medium is a mixture of water and 40% ethylene glycol at a temperature of 50 °C.

Form the table we obtain the constants C=0.0043 e b=0.911 and consequently the adjustment factor:

$$f = (0.0043 \cdot 40) + 0.911 = 1.083$$

The corrected differential pressure for pure water is therefore:

$$\Delta P_{pw} = (15 / 1.083) = 13.85 \text{ kPa}$$



EN Pressure drop diagrams

Below are the pressure drop diagrams of each valve and the tables with the relative Kv values as the preset position varies. The number of positions that can be set may vary from valve to valve.

DN65

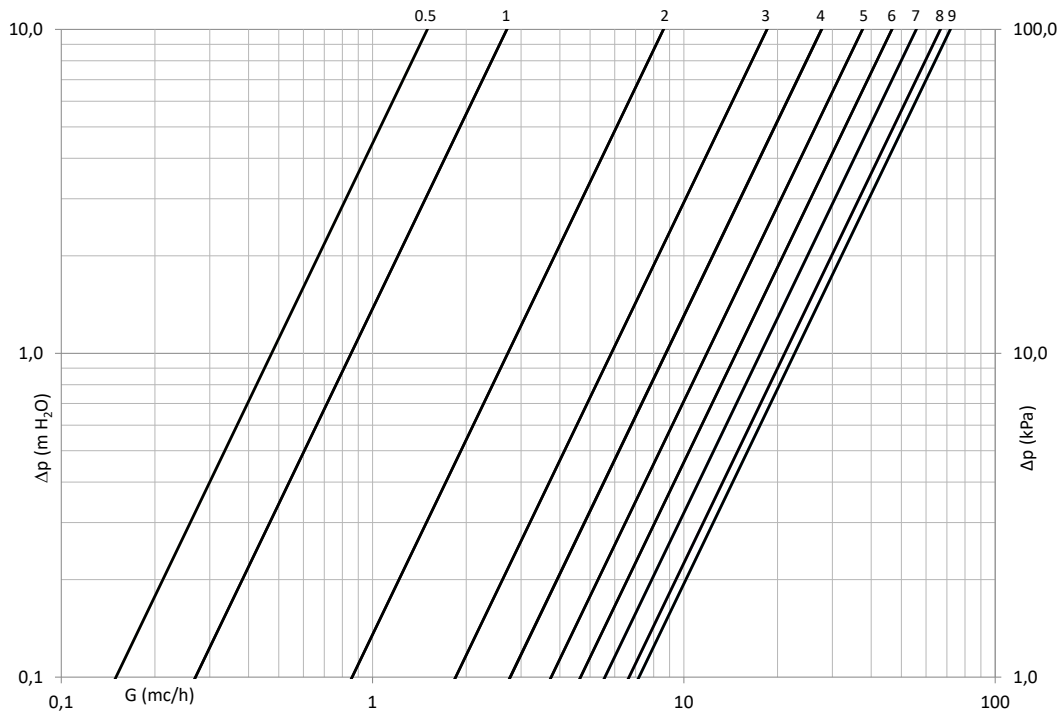

Setting	Kv
0.0	0
0.5	1.5
1.0	2.7
1.5	3.8
2.0	8.6
2.5	14
3.0	18.5
3.5	23.4
4.0	27.7
4.5	32.5
5.0	37.5
5.5	42.5
6.0	46.6
6.5	51.6
7.0	55.8
7.5	62.3
8.0	66.7
8.5	70.2
9.0	71.8

DN80

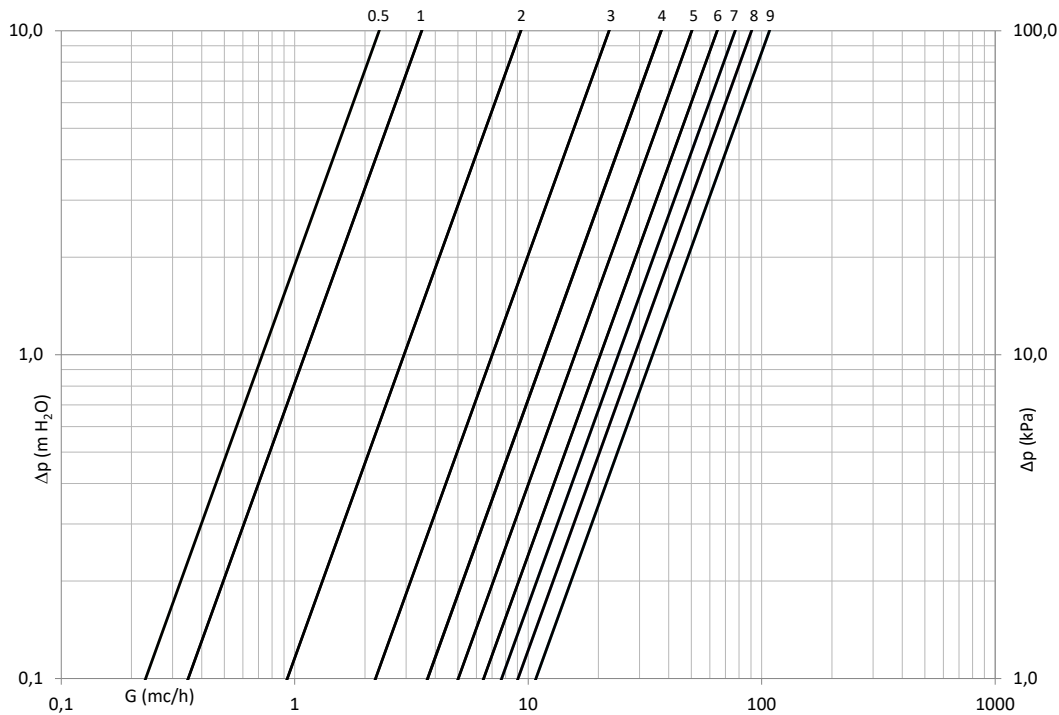

Setting	Kv
0.0	0
0.5	2.3
1.0	3.5
1.5	4.1
2.0	9.3
2.5	14.5
3.0	22.2
3.5	29
4.0	37.1
4.5	43.2
5.0	50.2
5.5	58.6
6.0	64.5
6.5	71.2
7.0	77
7.5	84
8.0	90.5
8.5	97.1
9.0	108



DN100

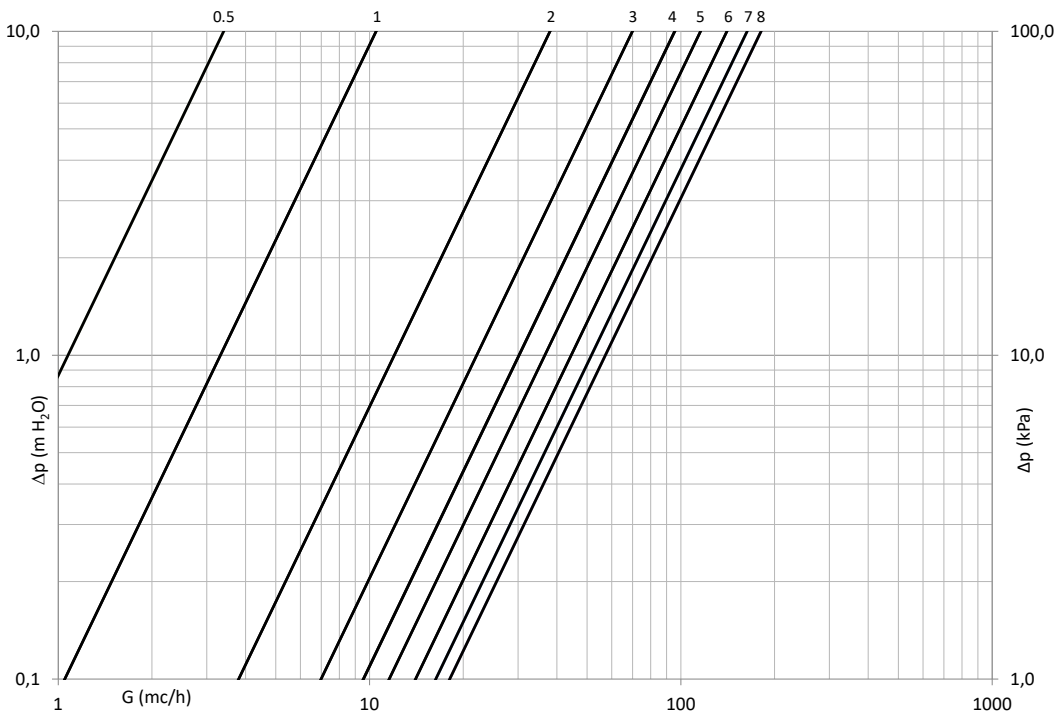

Setting	Kv
0.0	0
0.5	3.4
1.0	10.5
1.5	23.9
2.0	38
2.5	54.3
3.0	69.9
3.5	83.1
4.0	95.6
4.5	105.8
5.0	115.7
5.5	128.7
6.0	140.6
6.5	154
7.0	163.3
7.5	173.4
8.0	181

DN125

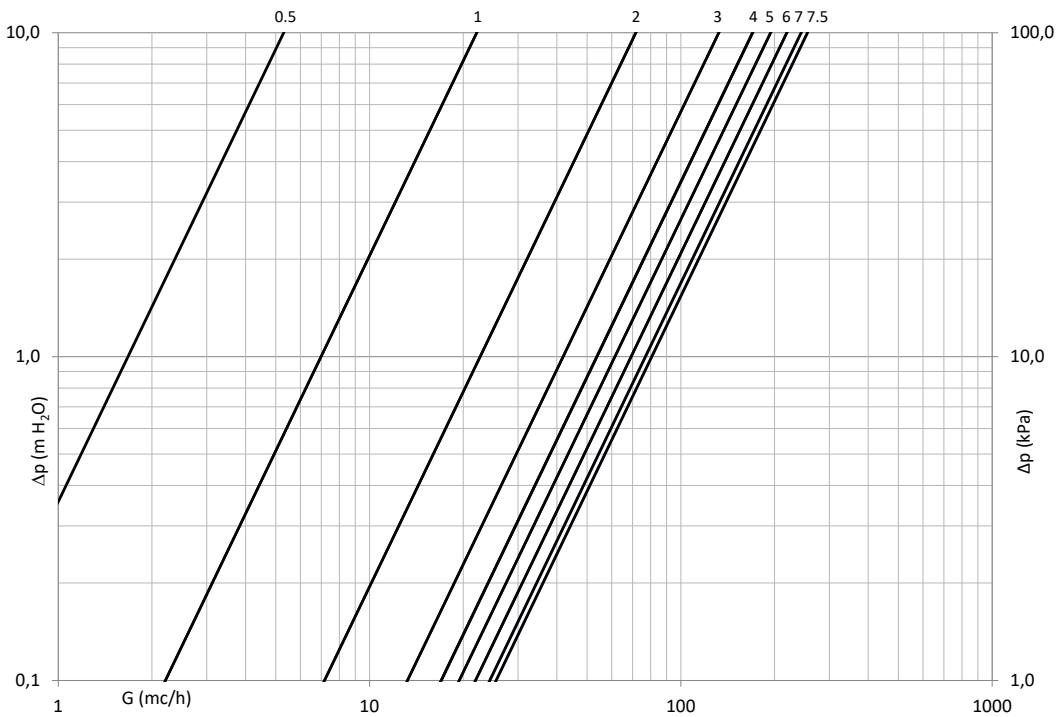

Setting	Kv
0.0	0
0.5	5.3
1.0	22.1
1.5	42.6
2.0	71.7
2.5	104.7
3.0	132.4
3.5	155.2
4.0	170
4.5	182.4
5.0	194.2
5.5	207.4
6.0	219
6.5	232.5
7.0	243.4
7.5	255.2



DN150

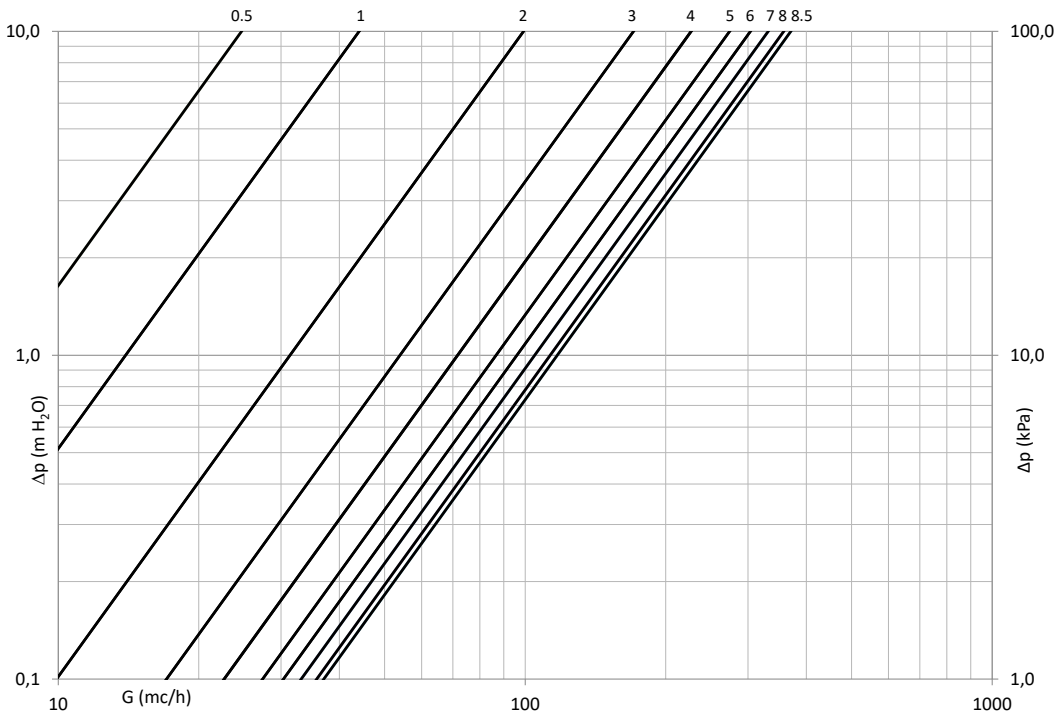

Setting	Kv
0.0	0
0.5	24.7
1.0	44.1
1.5	73.3
2.0	99.2
2.5	130.3
3.0	170.6
3.5	202.4
4.0	226.7
4.5	248.5
5.0	274
5.5	292
6.0	303.7
6.5	315
7.0	331.5
7.5	342.8
8.0	357.8
8.5	370.5

DN200

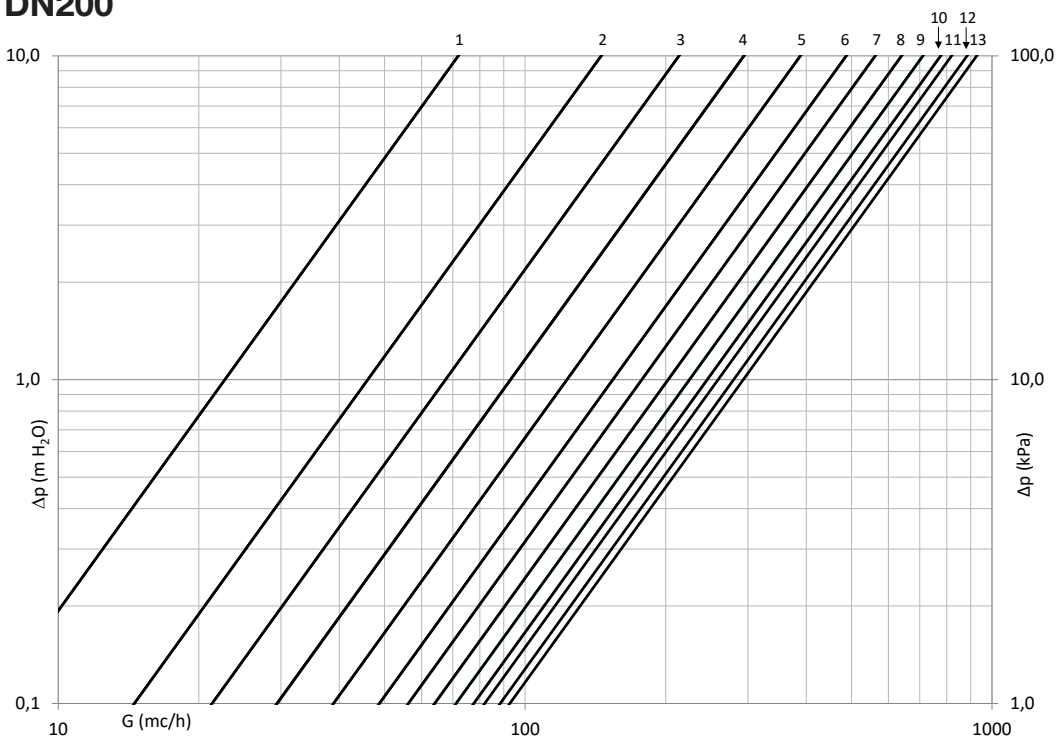

Setting	Kv
0.0	0
1.0	71.9
1.5	112.9
2.0	145.5
2.5	181
3.0	213.5
3.5	250.3
4.0	294.1
4.5	335.2
5.0	388.6
5.5	437.7
6.0	487.3
6.5	519.6
7.0	562.1
7.5	601
8.0	640
8.5	682.6
9.0	711.1
9.5	750.9
10.0	776.1
10.5	796.5
11.0	818.7
11.5	849.9
12.0	884.2
12.5	912.5
13.0	927.1



DN250

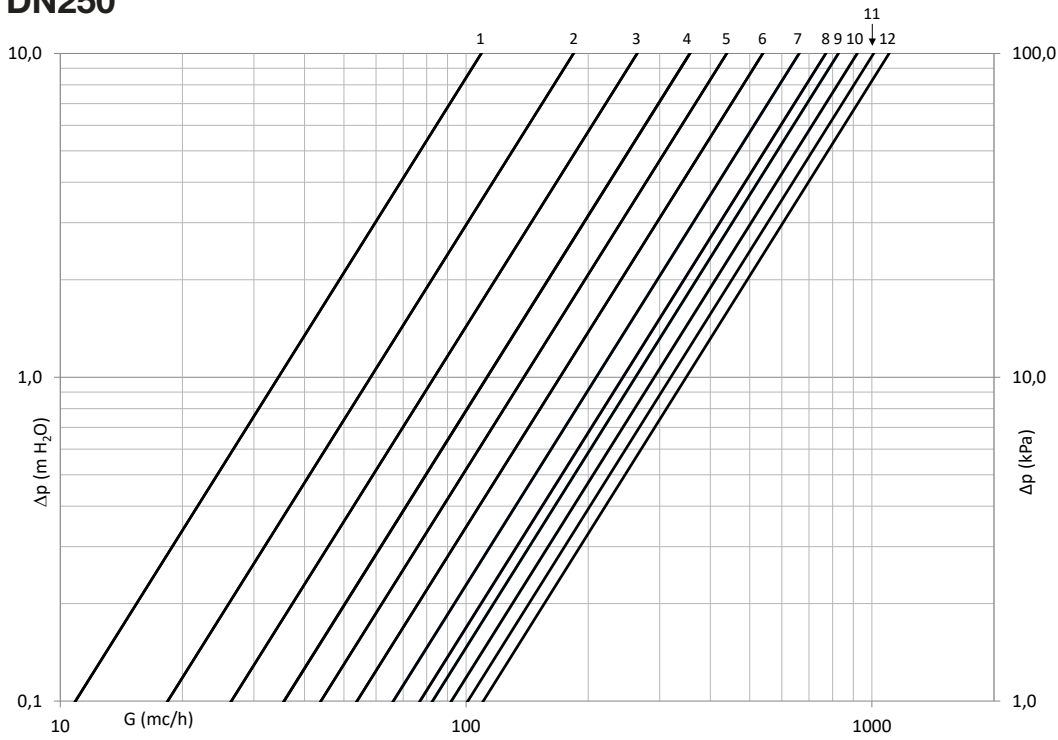

Setting	Kv
0	0
1	109
2	184
3	264
4	356
5	438.8
6	538.6
7	661.7
8	770
9	826.7
10	920
11	1010
12	1102.5

DN300

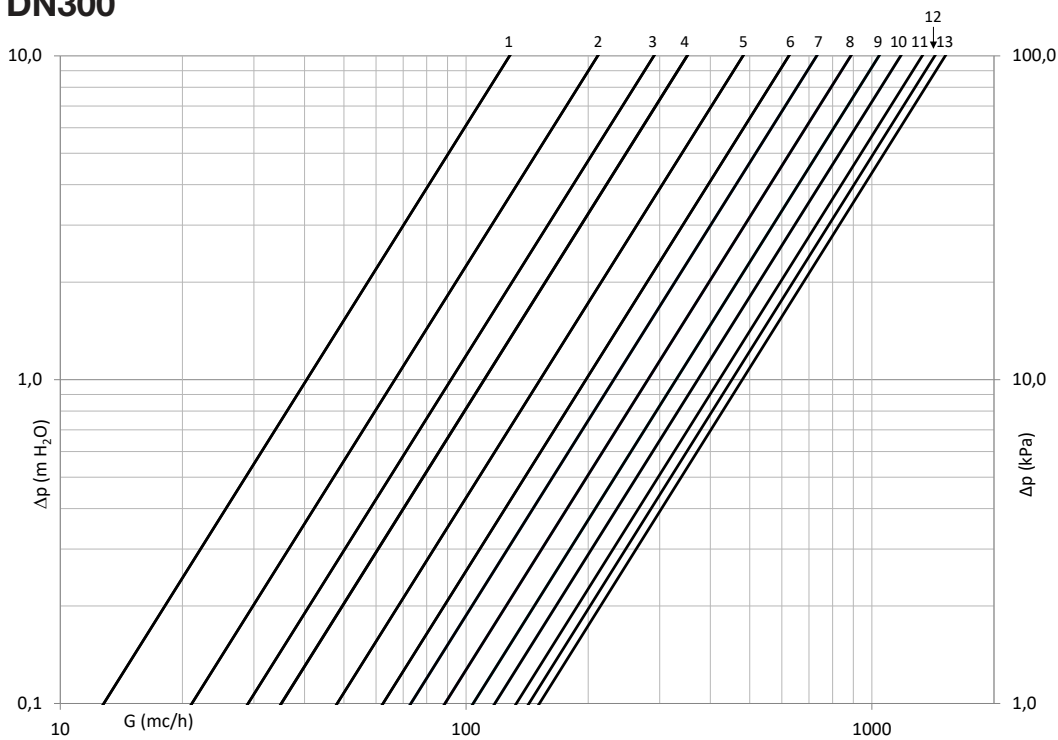

Setting	Kv
0	0
1	128
2	211
3	290.3
4	350.5
5	481.2
6	624.1
7	731
8	886.9
9	1042.1
10	1177.2
11	1330
12	1429
13	1516



EN Setting diagrams

Knowing the valve model used, the circulating flow rate and the pressure loss necessary for balancing the circuit, it is possible to obtain the adjustment position through the relative setting diagrams. The procedure to follow to read these diagrams is shown below:

1. Identify the circulating flow rate on the related scale (available in l/s or m³/h).
2. Identify the required pressure drop on the related scale (available in kPa or mH₂O).
3. Draw the line passing through these two points.
4. Identify the point of intersection between this line and the Kv axis.
5. Draw an horizontal line from this point up to the axis of the valve of interest (DN).
6. The point obtained on this axis is equal to the opening level at which the valve must be set.

EXAMPLE OF USE

Let's have a DN65 valve which has been selected to guarantee a pressure drop of 14 kPa with a flow rate of 20 m³/h. Using the appropriate diagram and following the procedure shown above the opening position needed is approximately of 6.8 (see figure below).

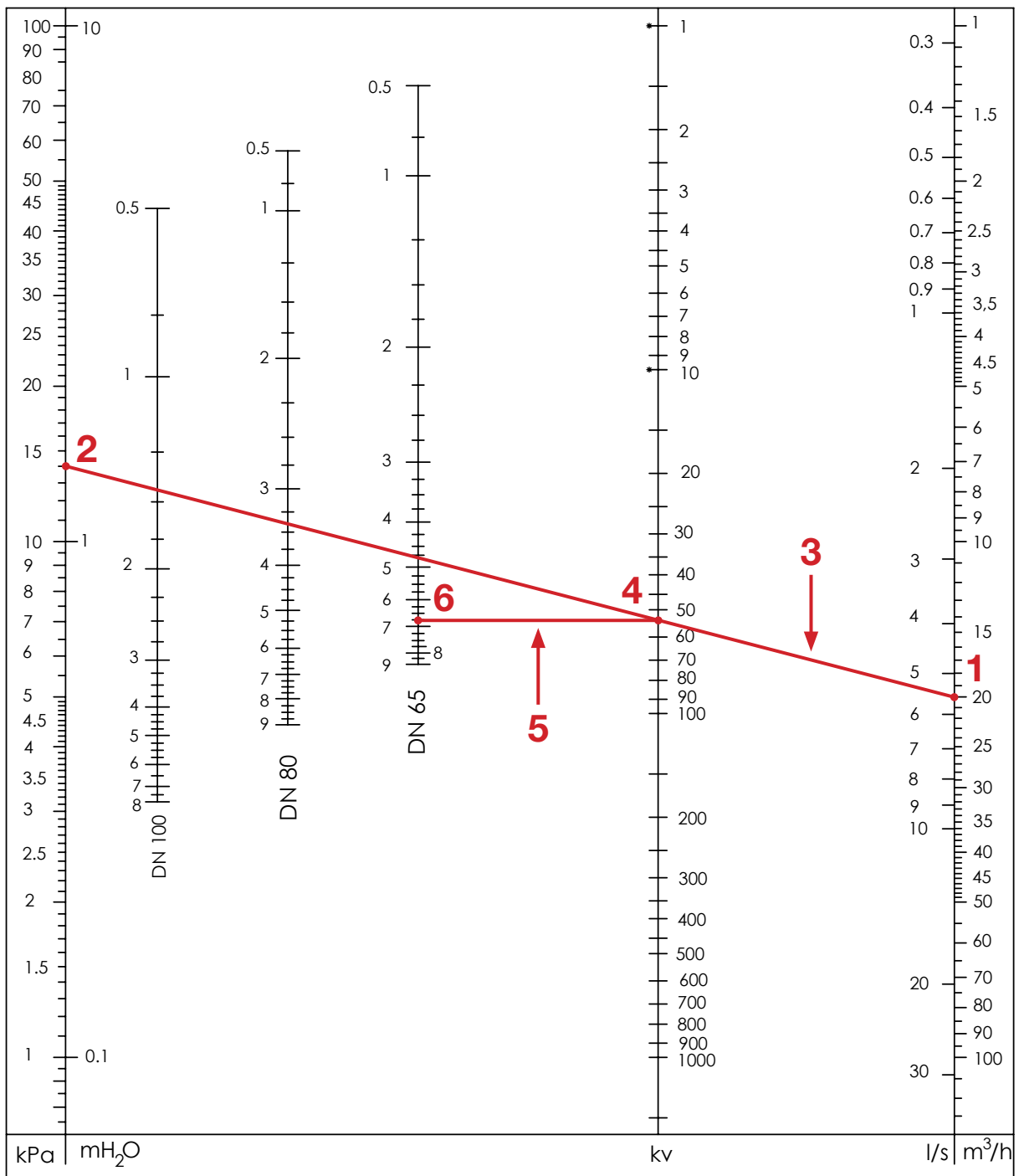

DN65-DN80-DN100

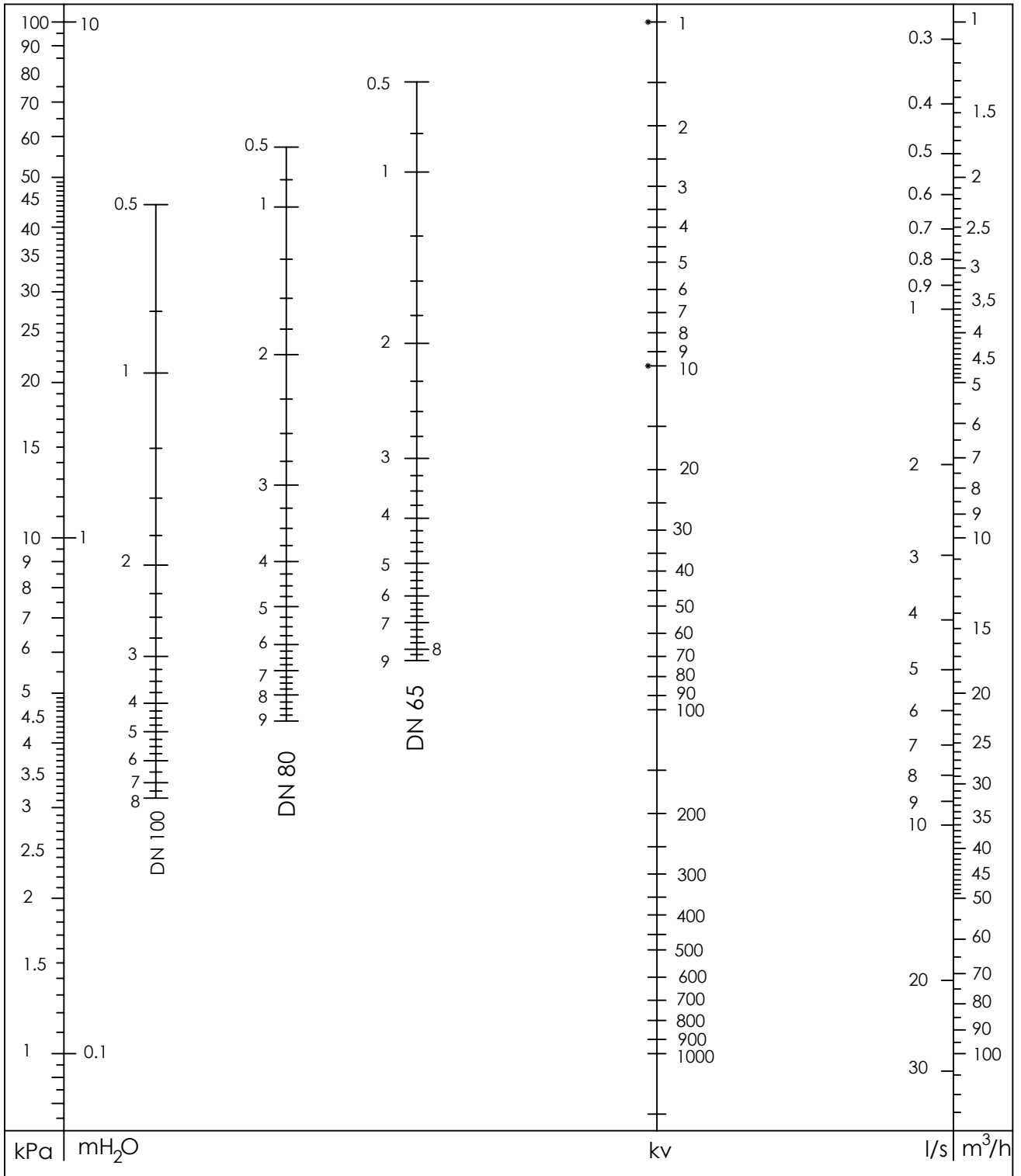

DN100-DN125-DN150

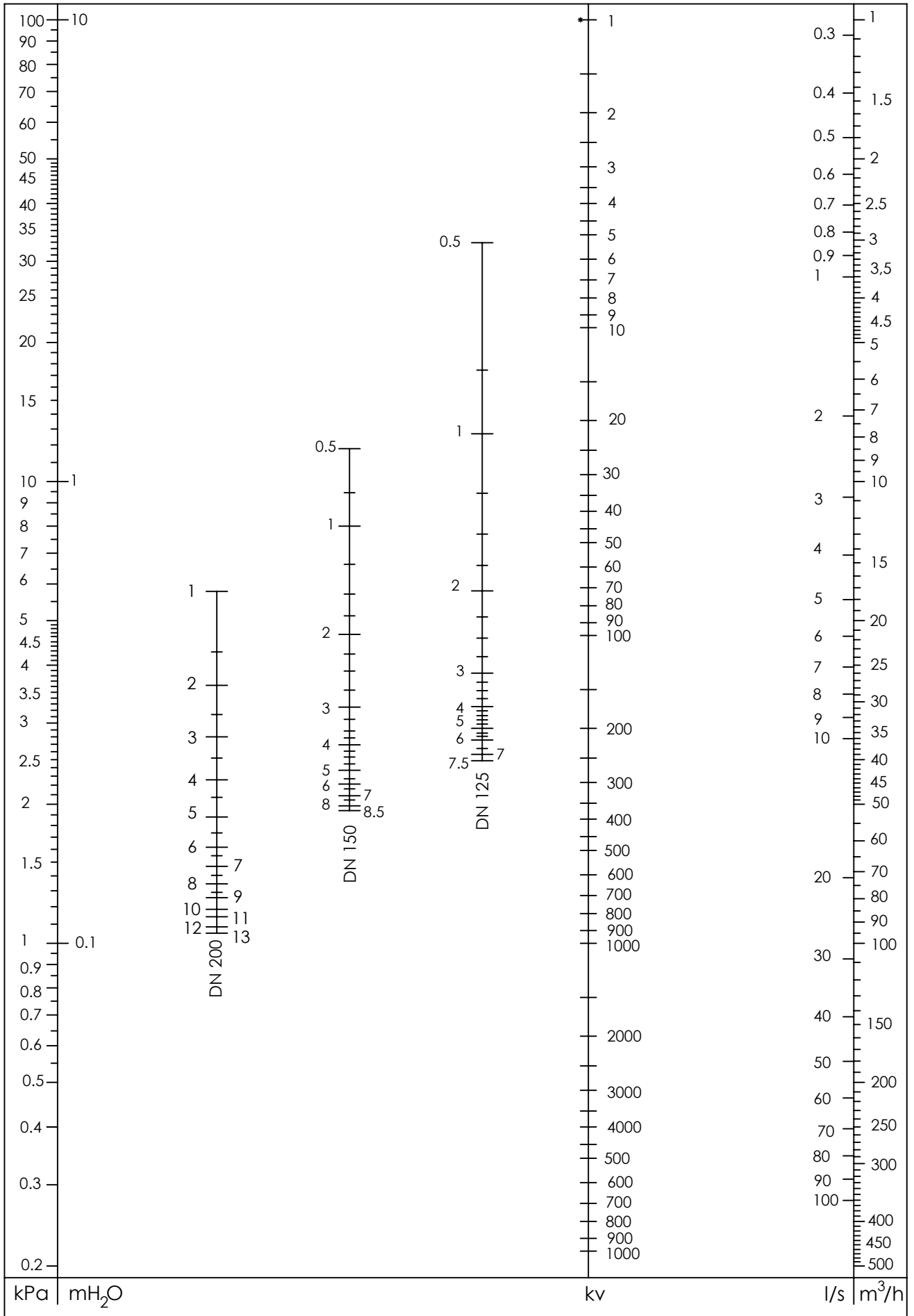

DN250-DN300

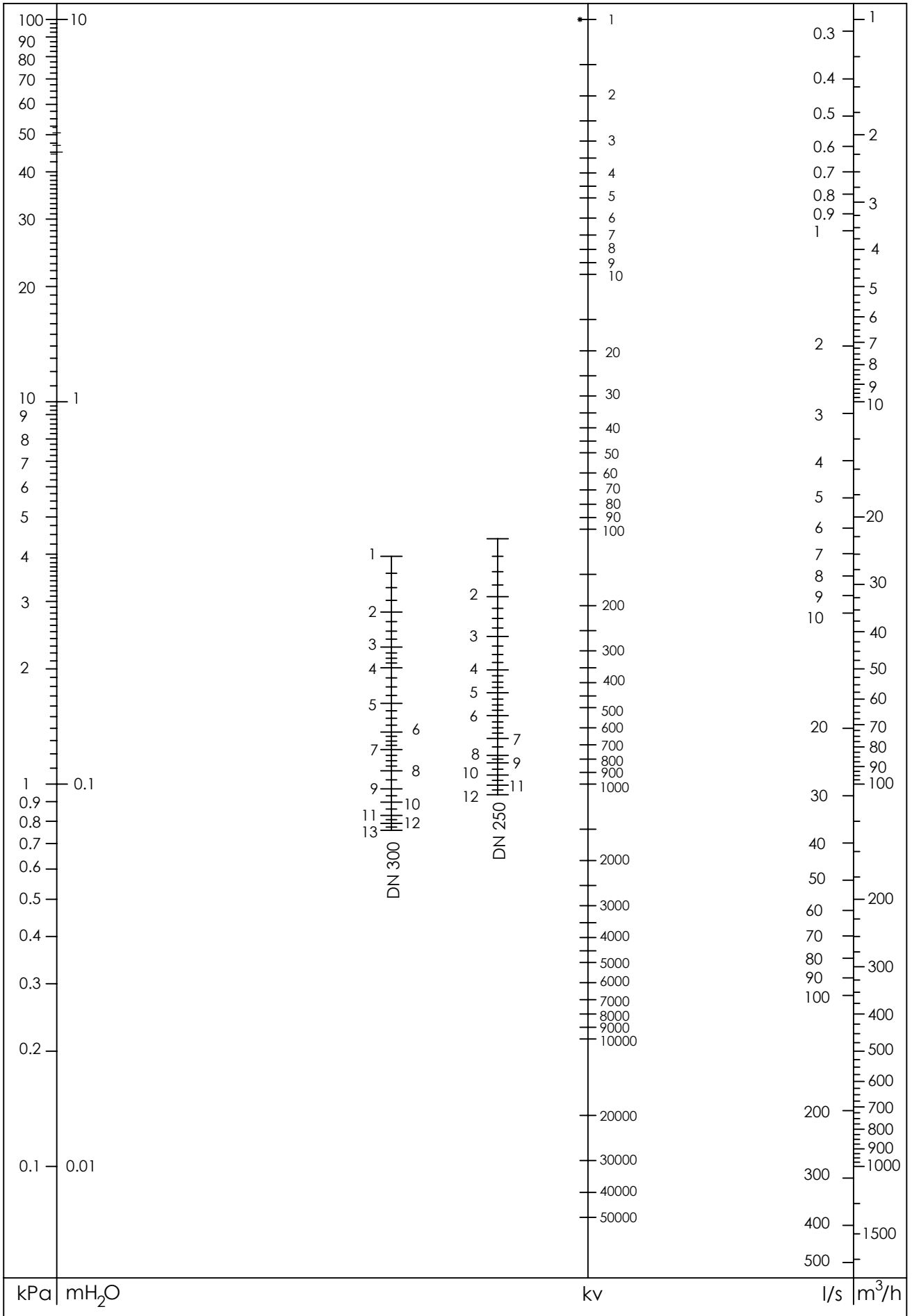

EN Measuring

Each valve is equipped with two self-sealing pressure ports which can be used to measure the introduced pressure drop. To carry out the measurement it is possible to use analogues differential pressure manometer or the digital ones such as the **MDP** (fig. a) and **MDPS2** (fig. b) manometers. For further informations about these devices please refers to the dedicated technical specifications.

The procedure to be carried out for measuring is as follows:

1. Unscrew the pressure port cap.
2. Insert the probes of the measuring device into the pressure ports.
3. Screw the probe ring nut to the pressure test port (for the MDP model) or release the blocking ring previously pushed (for the MDPS2 model).
4. After measuring, unscrew (or release) the probes to extract them.
5. Screw the pressure port cap back on.

Pay close attention during measurement in case of hot medium.

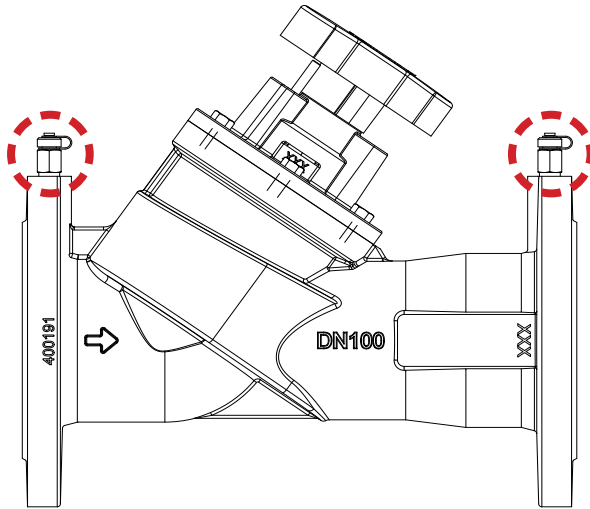

Fig. a



Fig. b

EN Warning

Before maintenance operation or disassembly:

- Wait for the cooling of the piping, the valve and the fluid.
- Let the pressure escape.
- Drain the line and pipes with toxic, corrosive, inflammable and caustic fluids.

Temperature over 50°C and under 0°C can cause damage to people.

Assembly, disassembly, commissioning and maintenance operations must be carried out by **trained personnel** and in compliance with the instructions and local safety regulations.



EN Storage and transportation

In order to ensure the integrity of the valve during storage and transport, observe the following instructions:

- Keep in a dry place, avoiding damages and dirt.
- Use suitable and sturdy packagings for transportation.
- Handle with care. Avoid hits, especially on the softest parts (wheel).
- Do not use the softest parts (wheel) to lift the valve.

EN About cavitation

As the liquid flows through the valve, due to section reduction its velocity and its dynamic pressure increase, and the corresponding static pressure decreases. If the static pressure value drops below the vapour pressure level, steam bubbles will form. These bubbles will be carried away by the fluid, imploding when the static pressure will exceed again the vapour pressure. Bubble implosion generates locally high temperatures and pressure shock waves which damage the valve and cause vibration and noise: **for the reasons cavitation phenomenon must be avoided.** Higher temperatures, lower static pressure and higher pressure drops across the valve usually increase the risk of cavitation.

EN Identification paper label

In order to memorize the setting given to the valve and facilitate any future adjustment and maintenance operations, it is possible to fill out the identification paper label placed below and combine it with the valve.

	Art. SB1/SB1T
Valve ref: _____	
Turn: _____	
Kv: _____	
Delta P: _____	
Flow rate: _____	
	IST239

EN Generals

Pettinaroli does not accept any liability for improper or wrong use of this product.

Always protect the valve by using strainers upstream of the valve and, in any case, make sure water quality complies with UNI 8065 standards (Fe < 0.5 mg/kg and Cu < 0.1 mg/kg).

The product color may be different with the actual product color due to printing procedure. The appearance and specifications may change with no prior notice for improvement. The data and photo should not be used without permission of the copyright holder.

Fratelli Pettinaroli Spa

Via Pianelli, 38 - 28017 San Maurizio d'Opaglio (NO) - Italy
 Tel. +39 0322 96217 - +39 0322 96545 - Fax +39 0322 96546
 info@pettinaroli.com - www.pettinaroli.com

