

Warning!

- During the installation make sure power is OFF.
- Fixtures must be installed by a qualified electrician in accordance with all national and local electrical and construction codes and regulations.
- Electrostatic sensitive devices (ESD). Handle with necessary precautions to avoid EED.
- Do not use chemicals or abrasives to clean this product. Use soft mat only. Avoid scratch the surface.
- Incorrect assembly can cause malfunction.
- Fluvia is not responsible of any incorrect use of the product.
- Light source can only be replace by manufacturer, its service technician or other qualified personnel.
- Regulation compatible with the Digital Addressable Lighting Interface.
- Install outside the accessible space.

¡Advertencia!

- Durante la instalación asegúrese que la alimentación eléctrica esté desconectada.
- Las luminarias deben ser instaladas por un electricista cualificado y cumpliendo todas las normas y regulaciones, tanto nacionales como locales, sobre instalaciones eléctricas.
- Dispositivos sensibles o descargas electrostáticas. (ESD). Manipular con las precauciones necesarias para evitarlas.
- No usar productos químicos o abrasivos para limpiar el producto. Usar solamente una gamuza suave. No arañar la superficie.
- Un montaje incorrecto puede causar averías.
- Fluvia no se hace responsable de cualquier uso indebido del producto.
- Fuente de luz que únicamente puede reemplazarse por el fabricante, su servicio técnico u otra persona cualificada.
- Regulación compatible con Digital Addressable Lighting Interface.
- Instalar fuera del volumen de accesibilidad.

Warning!

- Stellen Sie vor die Installation sicher, dass die Stromversorgung ausgeschaltet ist.
- Die Geräte müssen von einem qualifizierten Elektriker gemäß den nationalen und örtlichen Elektro- und Bauvorschriften installiert werden.
- Elektrostatiscche empfindliche Geräte (ESD). Handle mit den notwendigen Vorsichtsmaßnahmen, um sie zu vermeiden.
- Verwenden Sie keine Chemikalien und Scheuermittel, um dieses Produkt zu reinigen. Verwenden Sie nur weiches Wildleder. Vermeiden Sie die Oberfläche zu kratzen.
- Falsche Montage kann zu Fehlfunktionen führen.
- Fluvia ist nicht verantwortlich für jede unsachgemäße Verwendung des Produkts.
- Die Lichtquelle kann ausschliesslich vom Hersteller, von seinem technischen Dienst oder sonstigem Fachmann ausgewechselt werden.
- Regulierung kompatibel mit Digital Addressable Lighting Interface (DALI).
- Lichtquelle unzugänglich installieren.

Attention!

- Veuillez vous assurer que l'alimentation électrique est débranchée au cours de l'installation.
- Les éclairages doivent être installés par un électricien qualifié dans le respect des normes et réglementations, nationales ou locales, portant sur les installations électriques.
- Équipements sensibles aux décharges électrostatiques. (ESD). Manipuler en prenant les précautions nécessaires.
- Ne pas utiliser de produits chimiques ou abrasifs pour nettoyer le produit. Utiliser seulement une chamoisine. Ne pas gratter la surface.
- Un montage incorrect peut causer des pannes.
- Fluvia ne saurait être tenu pour responsable de toute mauvaise utilisation du produit.
- Source de lumière qui peut être remplacée uniquement par le fabricant, son service technique ou une personne qualifiée.
- Réglage compatible avec Digital Addressable Lighting Interface.
- Installer à l'extérieur de l'espace d'accès.

Avvertenza!

- Durante l'istallazione bisogna assicurarsi che l'alimentazione elettrica sia spenta.
- Le apparecchiature devono essere istallate da un elettricista qualificato rispettando le norme e i regolamenti nazionali ed internazionali riguardanti istallazioni elettriche.
- Dispositivi sensibili elettrostatici (ESD). Adottare le precauzioni necessarie durante l'uso (EED). Non utilizzare prodotti chimici o abrasivi per pulire questo prodotto.
- Utilizzare solo un panno liscio. Non graffiare la superficie.
- Un montaggio incorretto puo provocare danni all'apparecchio
- Fluvia non è responsabile di qualsiasi uso incorretto del prodotto.
- Sorgente luminosa che può essere sostituita solo dal produttore, dal suo servizio tecnico o da un'altra persona qualificata.
- Regolazione compatibile con Digital Addressable Lighting Interface.
- Installare fuori dal volume di accessibilità.

Avvertisement

- Durante a instalação, e preciso assegurar-se de que a alimentação eléctrica está desligado.
- As luminarias devem ser instaladas por um electricista qualificado e cumprindo sempre todas as normas e regulamentos, tanto nacionais como locais, sobre instalações eléctricas.
- Dispositivos sensíveis a descargas electrostaticas. (ESD). Para evitar descargas electrostatica, tomaras precauções necessárias ao manipular o produto.
- Não utilizar produtos químicos ou abrasivos para limpar o produto. Utilizar somente uma flanela macia. Nao riscar o supertície.
- Uma montagem incorrecta pode causar avarias.
- A Fluvia não assume nenhuma responsabilidade por qualquer utilização imprópria do produto.
- Fonte de luz que pode ser substituída unicamente pelo fabricante, o serviço técnico ou outra pessoa qualificada.
- Regulação compatível com Digital Addressable Lighting Interface.
- Instalar fora do volume de acessibilidade.

Внимание!

- Во время установки убедитесь в том, что электрическое питание отключено.
- Осветительные приборы должны устанавливаться только квалифицированным электриком, с соблюдением всех норм и правил по электрическим установкам, как национальных, так и местных.
- Устройства, чувствительные к электростатическим разрядам (ESD). Обращаться осторожно в целях предотвращения разрядов.
- Запрещается пользоваться химическими или абразивными средствами для чистки изделия. Использовать только мягкую тряпочку. Не царапать поверхность.
- Неправильная сборка может привести к неисправностям.
- Fluvia не несет ответственности за неправильное использование изделия.
- Источник света может быть заменен производителем, его технической службой или другим квалифицированным специалистом.
- Регулировка совместима с цифровым адресуемым интерфейсом освещения (Digital Addressable Lighting Interface).
- Установить вне пределов досягаемости.

SIMON ELECTRIC, S.L. Krijanovskogo street ,15/5 office 316 / 117218 Moscow (+74) 956 468 400 (RUSSIA)



FLUVIA CONCEPT, S.L.

C/Musgo, 3 2ª planta/ 28023 Madrid
(+34) 917 080 555
fluvia@fluvia.com

MADE IN SPAIN



A991282 22-05-2018

SLIM SYSTEM & DROP

SUSPENDED



SPECIFICATIONS

ESPECIFICACIONES / TECHNISCHE DATEN / CARACTÉRISTIQUES TECHNIQUE
SPECIFICHE / ESPECIFICAÇÕES / СПЕЦИФИКАЦИЯ

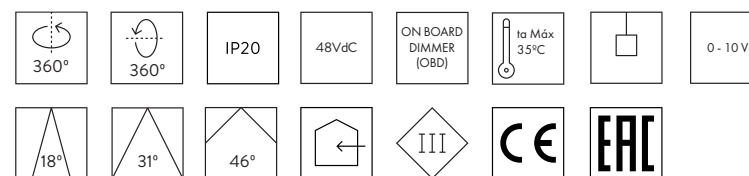

DESCRIPTION	WEIGHT (g)	POWER (W)
DROP MINI	400	13.5
DROP	615	19
SLIM SYSTEM 0,9m	450	29
SLIM SYSTEM 1,2m	575	42
SLIM SYSTEM 1,5m	700	56
START SECTION WITH POWER INPUT	380	-
END COVER	105	-
COUPLING CONNECTOR	90	-
COUPLING CONNECTOR WITH POWER INPUT	330	-
COUPLING CONNECTOR	75	-
90° HORIZONTAL ELBOW	150	-

DESCRIPTION	WEIGHT (g)	POWER (W)
90° HORIZONTAL ELBOW WITH POWER INPUT	390	-
90° VERTICAL ELBOW	150	-
BLIND SECTION 0,5m	200	-
BLIND SECTION 1m	315	-
BLIND SECTION 1,5m	435	-
X ACCESSORY	-	-
T HORIZONTAL ACCESSORY	-	-
T VERTICAL ACCESSORY	-	-
INTERMEDIATE CONNECTOR	60	-

Σ POTENCIAS ESTRUCTURA $\leq n$	DRIVER	n (MAX POWER)
	240	216W
	100	90W
	72	64W

FLUVIA

A

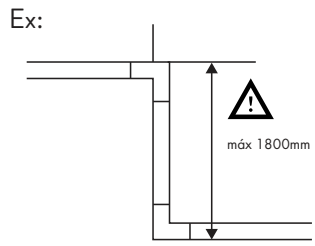

B

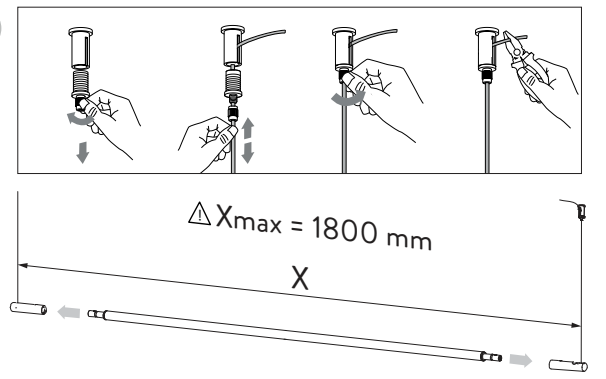

⚠

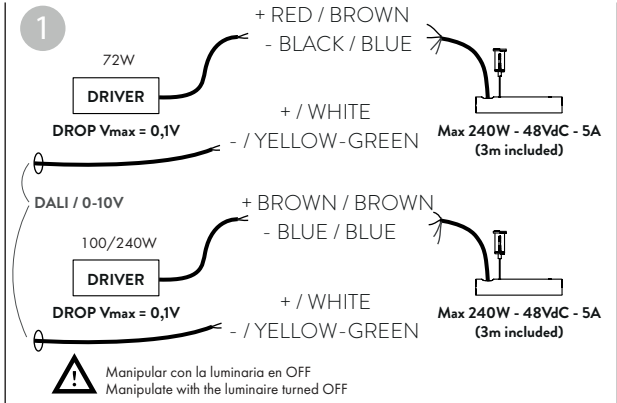

2

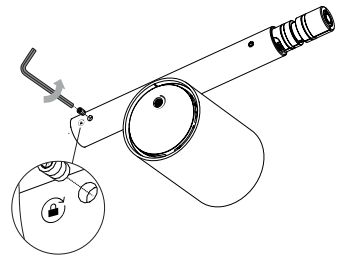

3

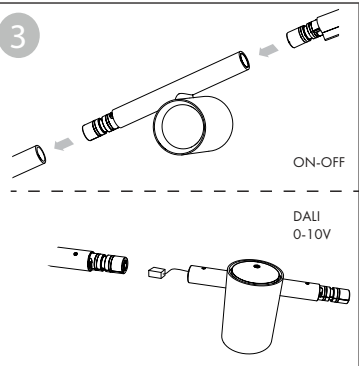

4

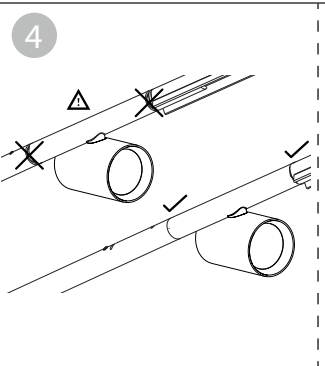

⚠ DALI 0-10V

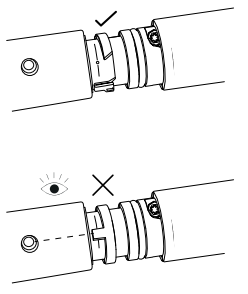

5

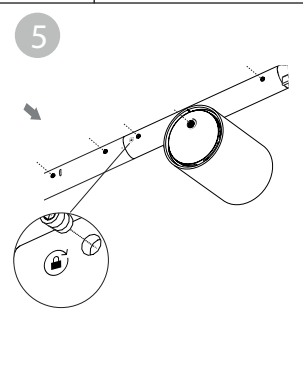

6

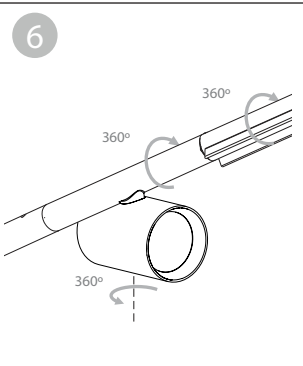

7

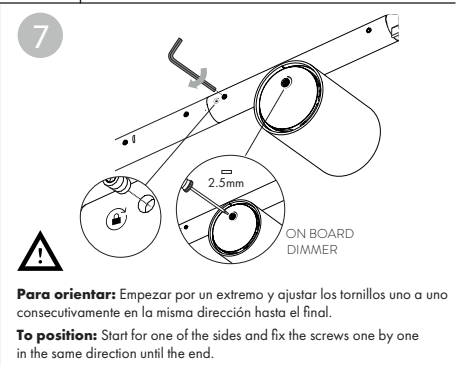

A

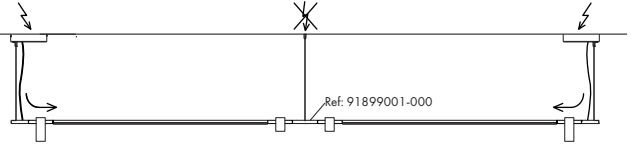

B

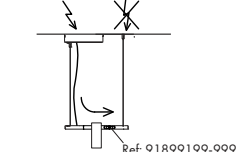

C

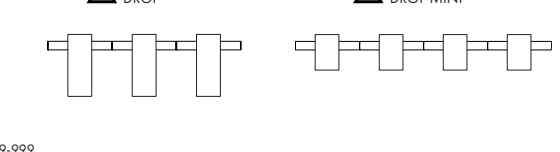

D

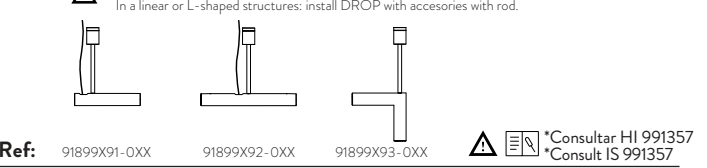

SLIM SYSTEM

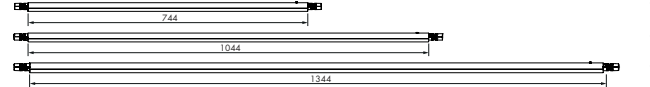

BLIND SECTION

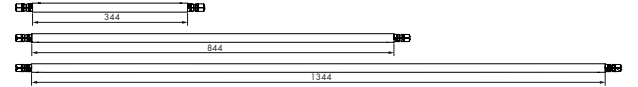

DROP MINI

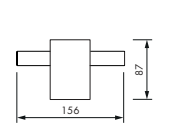

ACCESSORIES

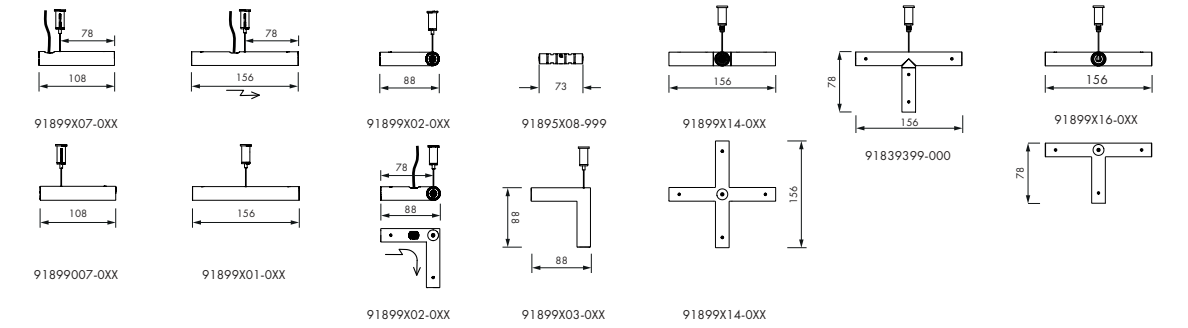

DROP

