

11. RAS_3MU2VAG_18

23-05-2019

RAS_3MU2VAG_18

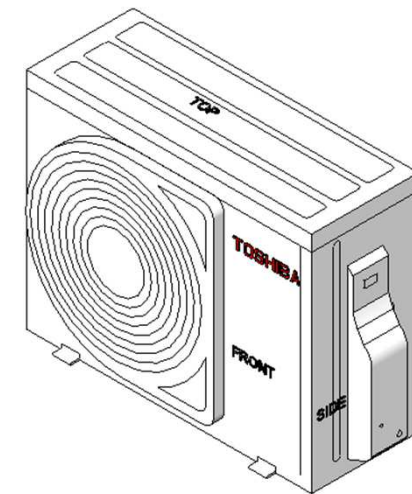
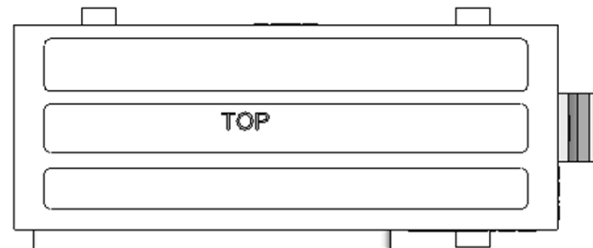
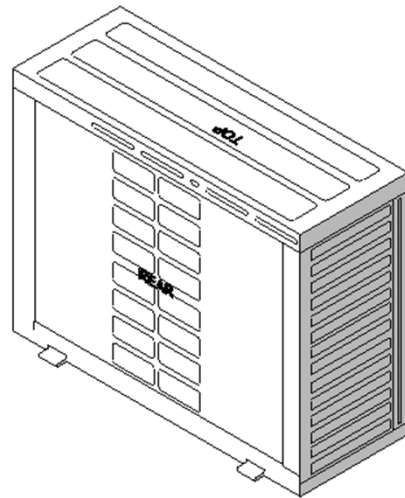
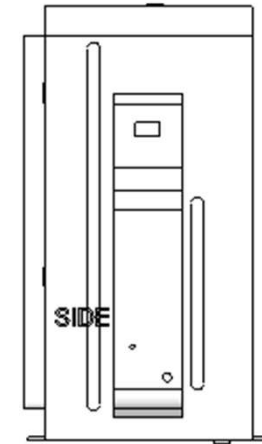
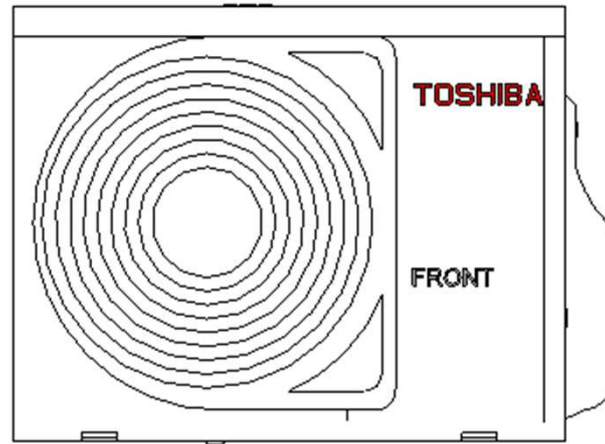
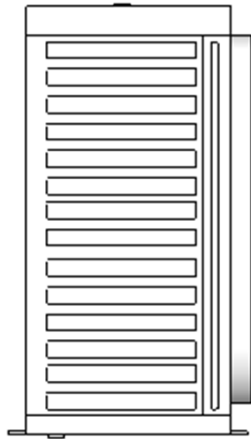

RAS_3MU2VAG_18

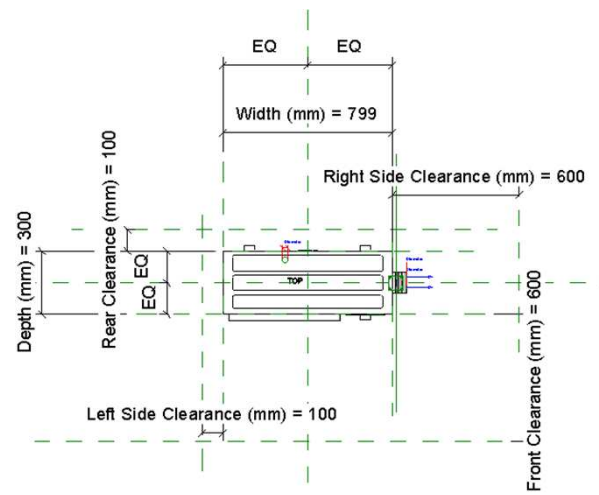
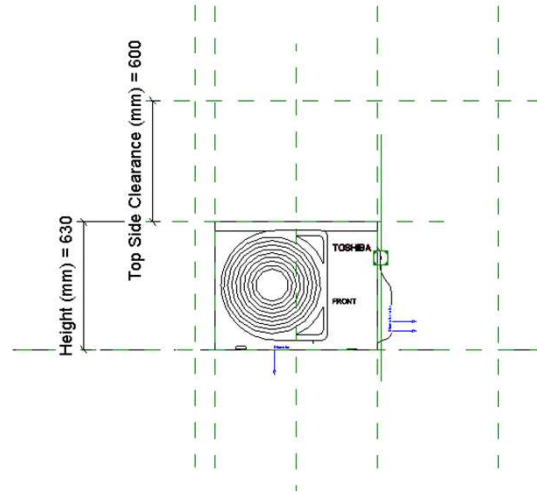

RAS_3MU2VAG_18 Service Area

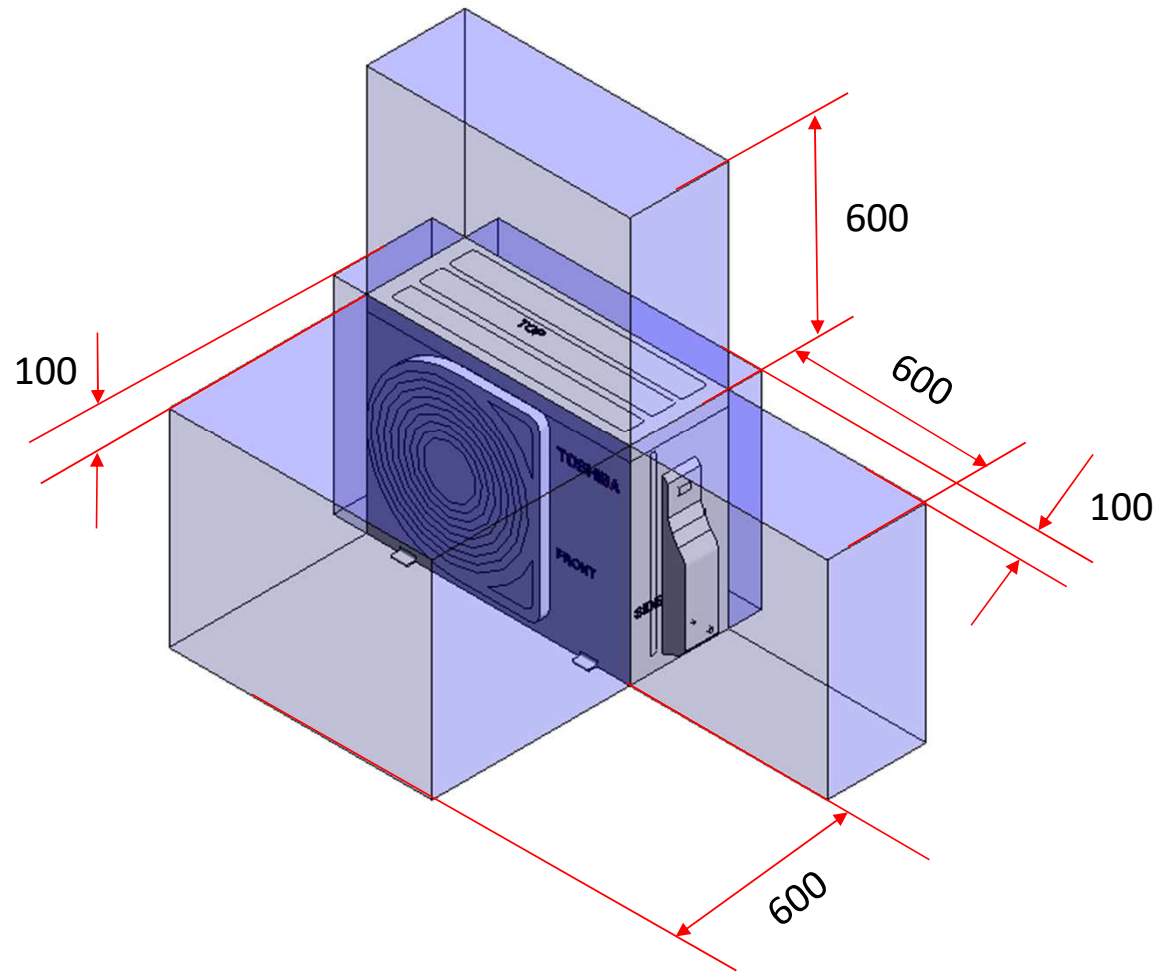

Electrical Connector

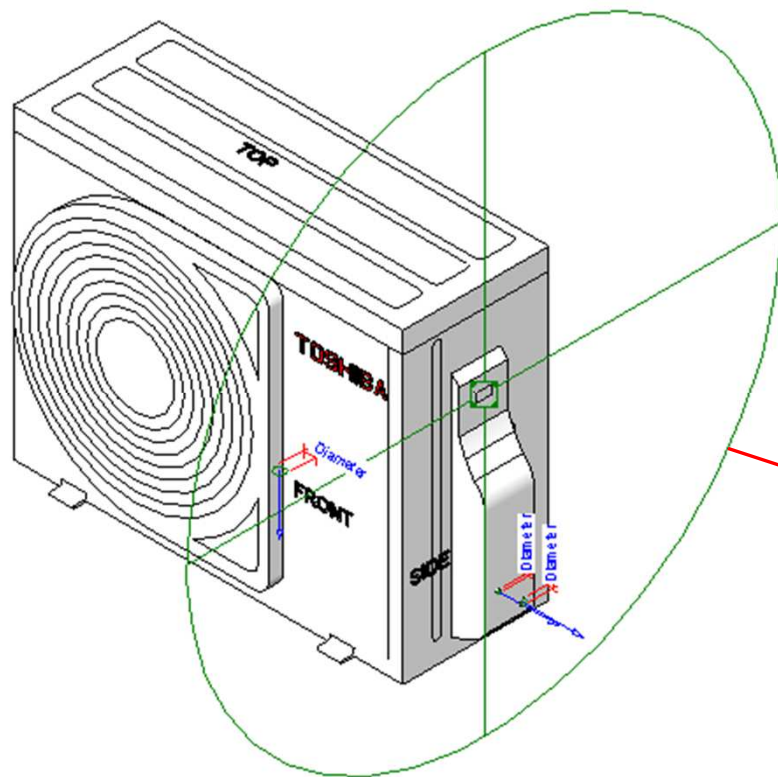

Connector Element (1) Edit Type	
Electrical - Loads	
System Type	Power - Unbalanced
Number of Poles	1
Power Factor State	Lagging
Load Classification	Other
Load Sub-Classification Motor	<input type="checkbox"/>
Voltage	0.00 V
Apparent Load Phase 1	0.00 VA
Apparent Load Phase 2	0.00 VA
Apparent Load Phase 3	0.00 VA
Power Factor	1.000000
Identity Data	
Utility	<input type="checkbox"/>
Connector Description	ELECTRICAL CONNECTOR

Pipe Connectors

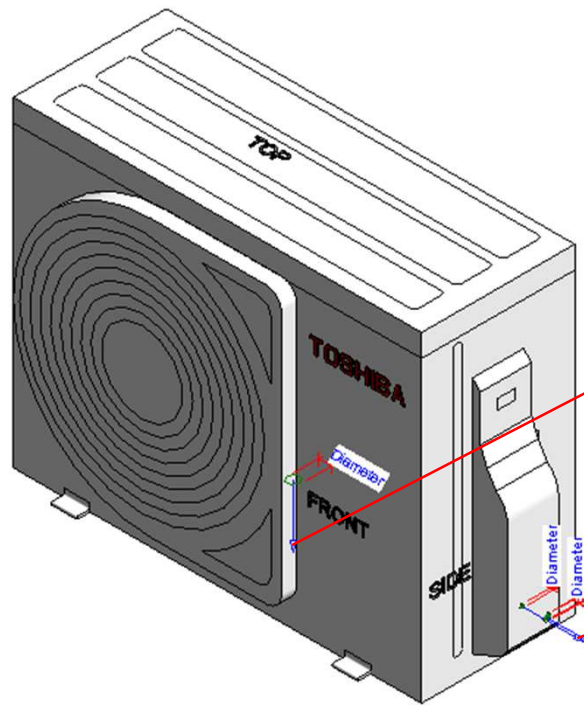

Properties	
R	
Connector Element (1)	Edit Type
Dimensions	
Diameter	25.0
Mechanical	
K Coefficient	0.000000
Flow Factor	0.000000
Flow Configuration	Calculated
Flow Direction	Bidirectional
Loss Method	Not Defined
Allow Slope Adjustments	<input type="checkbox"/>
System Classification	Vent
Mechanical - Flow	
Flow	0.00 L/s
Pressure Drop	0.00 Pa
Identity Data	
Utility	<input type="checkbox"/>
Connector Description	DRAIN PORT

Properties	
R	
Connector Element (1)	Edit Type
Dimensions	
Diameter	6.4
Mechanical	
K Coefficient	0.000000
Flow Factor	0.000000
Flow Configuration	Calculated
Flow Direction	Bidirectional
Loss Method	Not Defined
Allow Slope Adjustments	<input type="checkbox"/>
System Classification	Hydronic Supply
Mechanical - Flow	
Flow	0.00 L/s
Pressure Drop	0.00 Pa
Identity Data	
Utility	<input type="checkbox"/>
Connector Description	HYDRONIC SUPPLY (LIQUID) PORT @ 6.4 mm

Properties	
R	
Connector Element (1)	Edit Type
Dimensions	
Diameter	9.5
Mechanical	
K Coefficient	0.000000
Flow Factor	0.000000
Flow Configuration	Calculated
Flow Direction	Bidirectional
Loss Method	Not Defined
Allow Slope Adjustments	<input type="checkbox"/>
System Classification	Hydronic Return
Mechanical - Flow	
Flow	0.00 L/s
Pressure Drop	0.00 Pa
Identity Data	
Utility	<input type="checkbox"/>
Connector Description	HYDRONIC RETURN (GAS) PORT @ 9.5 mm

RAS-3M18U2AVG-E

Family Types		
Type name:	RAS-3M18U2AVG-E	
Search parameters		
Parameter	Value	Formula
Materials and Finishes		
Red	Colour RGB-250 000 000	=
White	Colour RGB-255 255 255	=
Electrical		
MOCP (A)	15	=
MCA (A)		=
Running current-Cooling (A)	5.64/5.39/5.17	=
Power consumption-Cooling (Kw)	1170	=
Running current-Heating (A)	7.54/7.22/6.92	=
Power consumption-Heating (Kw)	1580	=
Frequency (Hz)	50Hz	=
Voltage (V)	220-240V	=
Starting current	5.64	=
Dimensions		
Height (mm)	630.0	=
Width (mm)	799.0	=
Depth (mm)	300.0	=
Hydronic Supply Diameter (mm)	6.4	=
Hydronic Return Diameter (mm)	9.5	=
Weight (Kg)	46	=
Drain pipe	-	=
Duct diameters	-	=
Mechanical - Flow		
Static pressure		=
Sound pressure dB(A) Cooling/Heating- High	47 / 50	=
Airflow m3/h- Cooling/Heating	2177 / 2077	=
Mechanical - Loads		
Rated Capacity kW - Cooling/Heating	5.2 / 6.8	=
Rated Power Consumption kW - Cooling/Heat	1170 / 1580	=
Rated efficiency - EER / COP	4.44 / 4.30	=
Energy Analysis		
Energy class	A++ / A++	=
Seasonal efficiency - SEER / SCOP	6.80 / 4.60	=
Pdesigh	7.5 / 5.2	=

Visibility		
Service Area (default)	<input type="checkbox"/>	=
Front Clearance (mm) (default)	600.0	=
Rear Clearance (mm) (default)	100.0	=
Right Side Clearance (mm) (default)	600.0	=
Left Side Clearance (mm) (default)	100.0	=
Top Side Clearance (mm) (default)	600.0	=
Other		
Compressor Type	Hermetic DC Twin rotary compressor	=
Compressor detail - Motor output (kW)	1320	=
Operating range - Cooling (°C)	-10 - 46	=
Operating range - Heating (°C)	-20 - 24	=
Refrigerant information	R32	=
Identity Data		
Article Description	Multi R32	=
Article Type	RAS-3M18U2AVG-E	=
Assembly Code		=
Base Family Version		=
CB-NL Class		=
Content Supplier URL	www.hcltech.com	=
Copyright	©Toshiba / HCL	= "©Toshiba / HCL"
Cost		=
Custom	<input type="checkbox"/>	=
Description	Multi R32	=
EMCS	4	= "4"
ETIM Article Class	EC001213	= "EC001213"
Family Version		=
GLN		=
GTIN		=
Internal Art. No.		=
Keynote		=
MEPcontent Class	HEATPUMP	= "HEATPUMP"
Manufacturer	Toshiba	= "Toshiba"
Manufacturer Art. No.	RAS-3M18U2AVG-E	=
Manufacturer URL	https://www.toshiba-carrier.co.jp/global/	=
Model	RAS-3M18U2AVG-E	=
Product Line	TCTC	= "TCTC"
Revit Version		=
Stabu Code		=
Type Comments		=
Type Image		=
URL	https://www.toshiba-carrier.co.jp/global/	=
Watermarked By		=
Wholesaler		=
Wholesaler Art. No.		=



Thank You