

# VRF\_MMC1HP\_36-56

13-01-2021

# VRF\_MMC1HP\_36-56

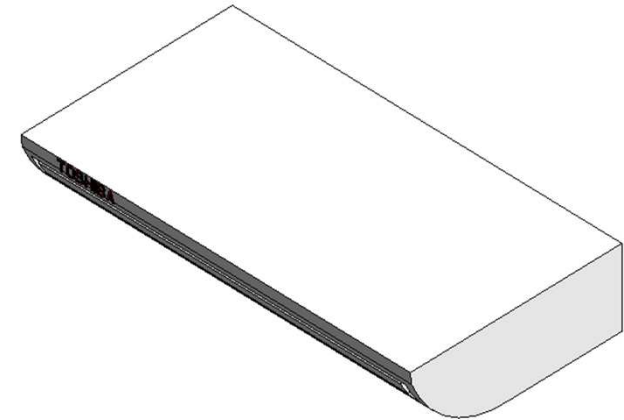
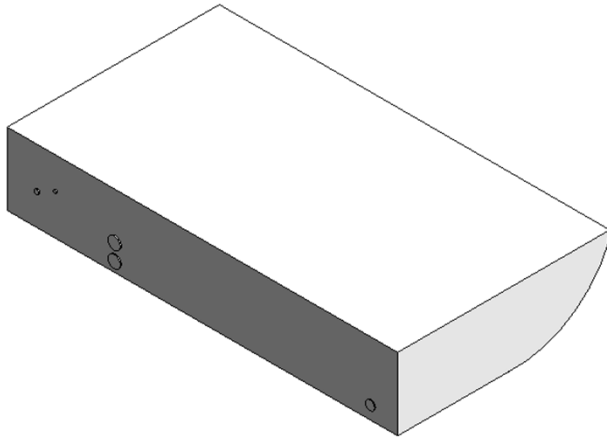

# VRF\_MMC1HP\_36-56

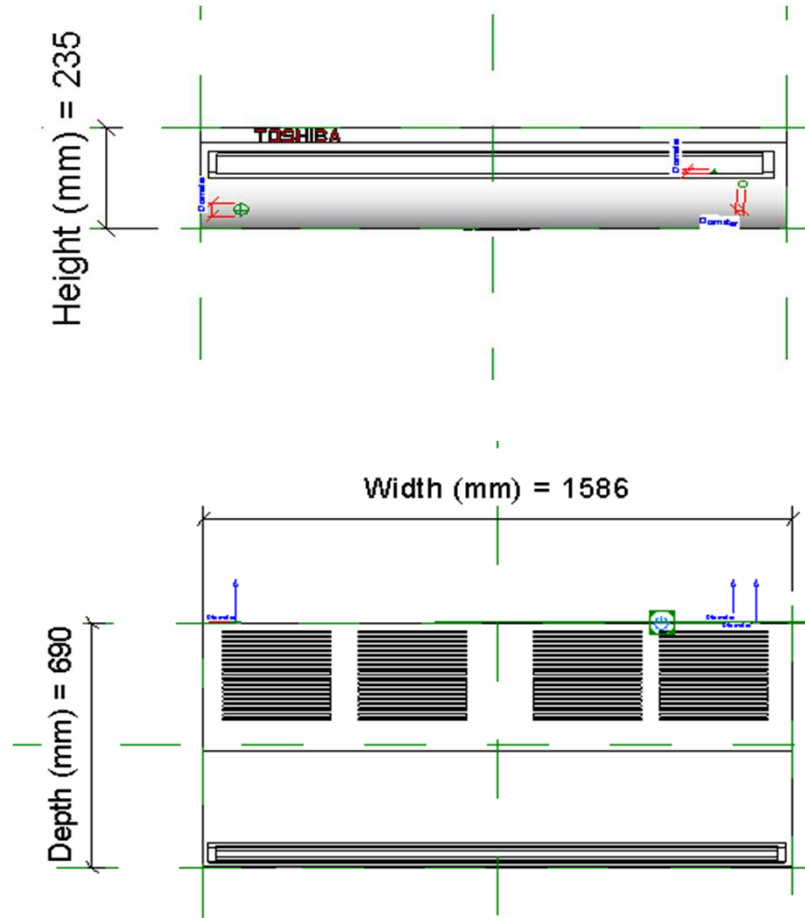

# VRF\_MMC1HP\_36-56\_Service Area

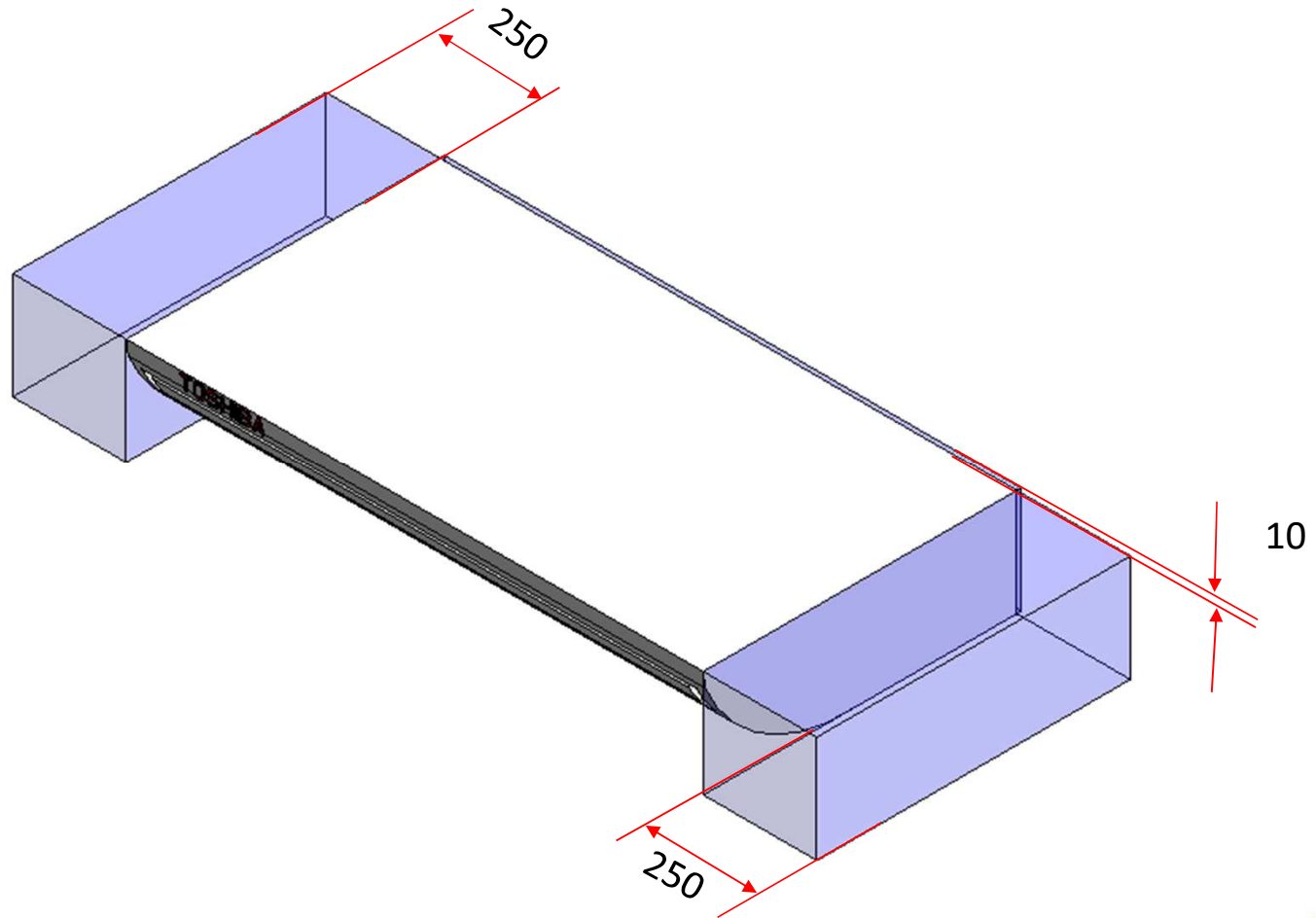

# VRF\_MMC1HP\_36-56

Visibility	
SERVICE AREA (default)	<input checked="" type="checkbox"/>
Right Side Clearance (default)	250.0
Left Side Clearance (default)	250.0
Back Clearance (default)	10.0

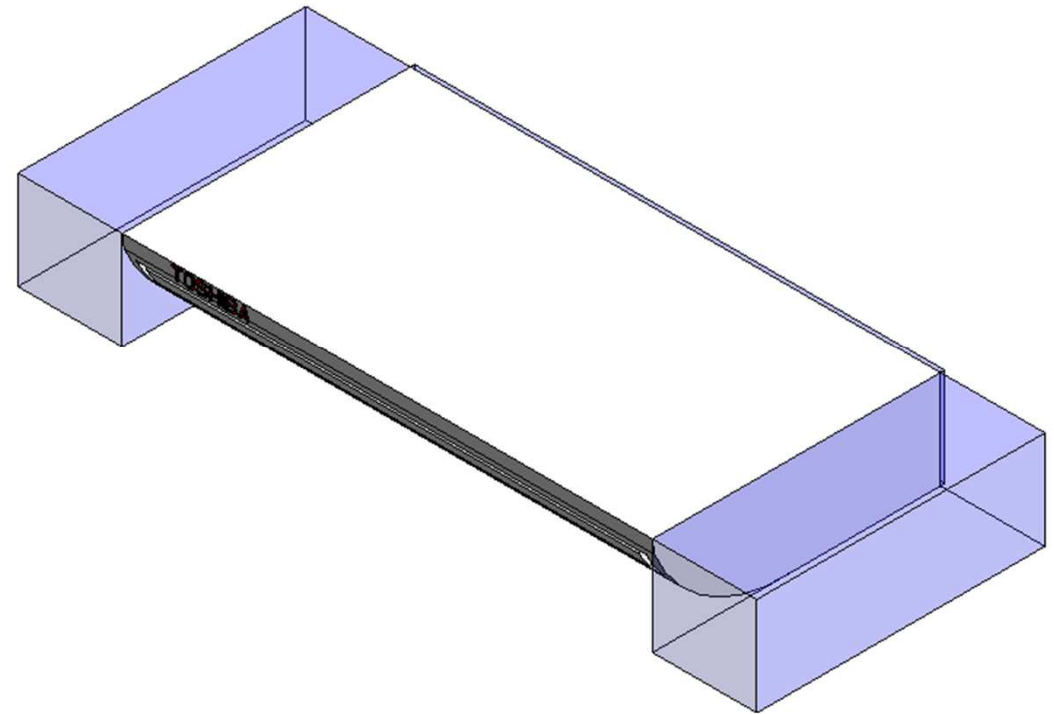

Service Clearance ON

# VRF\_MMC1HP\_36-56

Visibility	
SERVICE AREA (default)	<input type="checkbox"/>
Right Side Clearance (default)	250.0
Left Side Clearance (default)	250.0
Back Clearance (default)	10.0

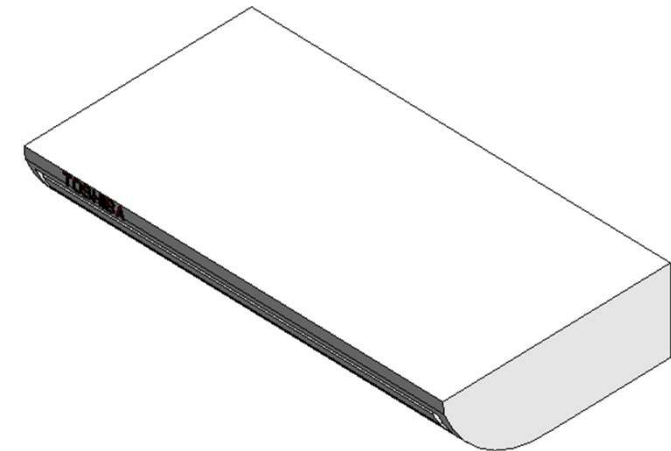

Service Clearance OFF

# Electrical Connector

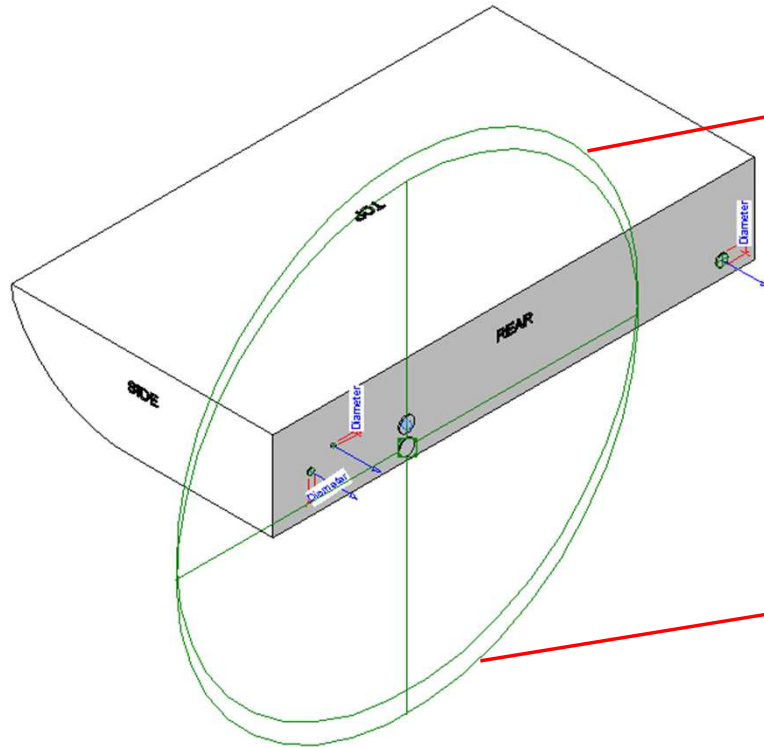

<b>R</b>	
Connector Element (1) <span>Edit Type</span>	
<b>Electrical - Loads</b>	
System Type	Controls
<b>Identity Data</b>	
Utility	<input type="checkbox"/>
Connector Description	CONTROL CABLE PORT

<b>R</b>	
Connector Element (1) <span>Edit Type</span>	
<b>Electrical - Loads</b>	
System Type	Power - Unbalanced
Number of Poles	1
Power Factor State	Lagging
Load Classification	Other
Load Sub-Classification Motor	<input type="checkbox"/>
Voltage	0.00 V
Apparent Load Phase 1	0.00 VA
Apparent Load Phase 2	0.00 VA
Apparent Load Phase 3	0.00 VA
Power Factor	1.000000
<b>Identity Data</b>	
Utility	<input type="checkbox"/>
Connector Description	ELECTRICAL CONNECTOR

# Pipe Connectors

Properties	
<b>R</b>	
Connector Element (1) <span>Edit T</span>	
Dimensions	
Diameter	9.5
Mechanical	
K Coefficient	0.000000
Flow Factor	0.000000
Flow Configuration	Calculated
Flow Direction	In
Loss Method	Not Defined
Allow Slope Adjustments	<input type="checkbox"/>
System Classification	Hydronic Supply
Mechanical - Flow	
Flow	0.00 L/s
Pressure Drop	0.00 Pa
Identity Data	
Utility	<input type="checkbox"/>
Connector Description	HYDRONIC SUPPLY (LIQUID) PORT @ 9.5mm

Properties	
<b>R</b>	
Connector Element (1) <span>Edit T</span>	
Dimensions	
Diameter	15.9
Mechanical	
K Coefficient	0.000000
Flow Factor	0.000000
Flow Configuration	Calculated
Flow Direction	Out
Loss Method	Not Defined
Allow Slope Adjustments	<input type="checkbox"/>
System Classification	Hydronic Return
Mechanical - Flow	
Flow	0.00 L/s
Pressure Drop	0.00 Pa
Identity Data	
Utility	<input type="checkbox"/>
Connector Description	HYDRONIC RETURN (GAS) PORT @ 15.9mm

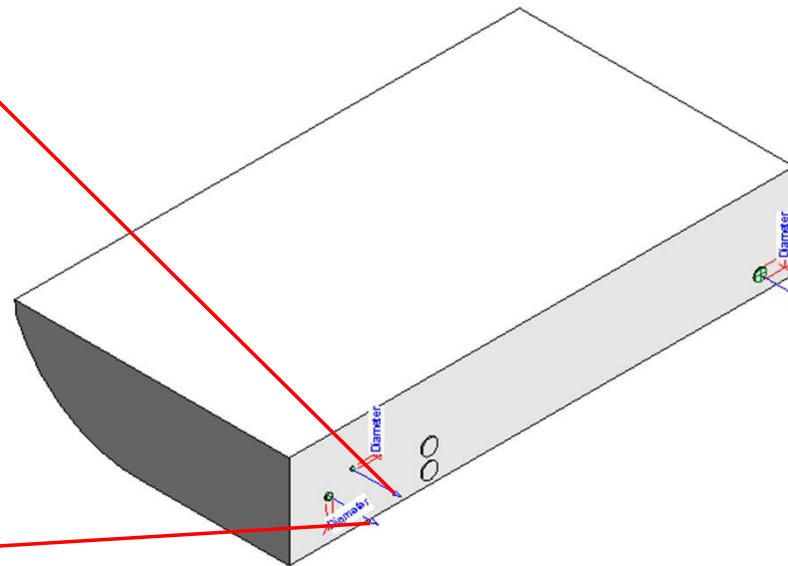

Properties	
<b>R</b>	
Connector Element (1)	
Dimensions	
Diameter	30.0
Mechanical	
K Coefficient	0.000000
Flow Factor	0.000000
Flow Configuration	Calculated
Flow Direction	Out
Loss Method	Not Defined
Allow Slope Adjustments	<input type="checkbox"/>
System Classification	Vent
Mechanical - Flow	
Flow	0.00 L/s
Pressure Drop	0.00 Pa
Identity Data	
Utility	<input type="checkbox"/>
Connector Description	DRAIN PORT



# MMC-UP0361HP-E

## Family Types

Type name: MMC-UP0361HP-E

Search parameters

Parameter	Value	Formula
<b>Materials and Finishes</b>		
Red	Colour RGB-255 000 000	=
White	Colour RGB-255 255 255	=
<b>Electrical</b>		
MOCP (A)	15	=
MCA (A)	1.11	=
Running current-Cooling (A)	0.8	=
Power consumption-Cooling (Kw)	0.083	=
Running current-Heating	-	=
Power consumption-Heating	-	=
Frequency (Hz)	50Hz 220-240V	=
Voltage (V)	60Hz 208-230V	=
Starting current (A)	1.16	=
<b>Dimensions</b>		
Height (mm)	235.0	=
Width (mm)	1586.0	=
Depth (mm)	690.0	=
Piping diameter Gas (mm)	15.9	=
Piping diameter Liquid (mm)	9.5	=
Drain Pipe(mm)	VP20(OD:26mm)	=
Duct diameters(mm)	-	=
<b>Mechanical - Flow</b>		
Static pressure	-	=
Sound pressure dB (A)- High	44	=
Sound pressure dB (A)- Mid	38	=
Sound pressure dB (A)- Low	32	=
Airflow m3/h- High	1860	=
Airflow m3/h- Mid	1350	=
Airflow m3/h- Low	1020	=
Power Consumption (W)- High	83	=
Power Consumption (W)- Mid	41	=
Power Consumption (W)- Low	24	=
<b>Mechanical - Loads</b>		
Seasonal and Rated Efficiency	-	=
Part Load	-	=
Capacities - Cooling (kW)	11.2	=
Capacities - Heating (kW)	12.5	=

## Family Types

Type name: MMC-UP0361HP-E

Search parameters

Parameter	Value	Formula
<b>Energy Analysis</b>		
Energy class	-	=
Capacity	-	=
Rated efficiency	-	=
<b>Visibility</b>		
SERVICE AREA (default)	<input type="checkbox"/>	=
Right Side Clearance (default)	250.0	=
Left Side Clearance (default)	250.0	=
Back Clearance (default)	10.0	=
<b>Other</b>		
Sold separately parts (Drain Pump Kit)	TCB-DP31CE	=
Sold separately parts (Elbow Piping Kit)	TCB-KP23CE	=
Refrigerant Information	R410A	=
Weight (Kg)	39	=
<b>Identity Data</b>		
Article Description	Ceiling	=
Article Type	MMC-UP0361HP-E	=
Base Family Version		=
CB-NL Class		=
Content Supplier URL	www.hcltech.com	= "www.hcltech.com"
Copyright	©Toshiba / HCL	= "©Toshiba / HCL"
Custom	<input checked="" type="checkbox"/>	=
EMCS	4	= "4"
ETIM Article Class	EC001213	= "EC001213"
Family Version		=
GLN		=
GTIN		=
Internal Art. No.		=
MEPcontent Class	HEATPUMP	= "HEATPUMP"
Manufacturer Art. No.	MMC-UP0361HP-E	=
Manufacturer URL	https://www.toshiba-carrier.co.jp/global/	=
Product Line	TCTC	= "TCTC"
Revit Version	2017	= "2017"
Stabu Code		=
Type Image		=
Keynote		=
Model	MMC-UP0361HP-E	=
Manufacturer	Toshiba	= "Toshiba"
Type Comments		=
URL	https://www.toshiba-carrier.co.jp/global/	=
Description	Ceiling	=
Assembly Code		=
Cost		=

# MMC-UP0481HP-E

## Family Types

Type name:

Search parameters

Parameter	Value	Formula
<b>Materials and Finishes</b>		
Red	Colour RGB-255 000 000	=
White	Colour RGB-255 255 255	=
<b>Electrical</b>		
MOCP (A)	15	=
MCA (A)	1.11	=
Running current-Cooling (A)	0.8	=
Power consumption-Cooling (Kw)	0.083	=
Running current-Heating	-	=
Power consumption-Heating	-	=
Frequency (Hz)	50Hz 220-240V	=
Voltage (V)	60Hz 208-230V	=
Starting current (A)	1.16	=
<b>Dimensions</b>		
Height (mm)	235.0	=
Width (mm)	1586.0	=
Depth (mm)	690.0	=
Piping diameter Gas (mm)	15.9	=
Piping diameter Liquid (mm)	9.5	=
Drain Pipe(mm)	VP20(OD:26mm)	=
Duct diameters(mm)	-	=
<b>Mechanical - Flow</b>		
Static pressure	-	=
Sound pressure dB (A)- High	44	=
Sound pressure dB (A)- Mid	41	=
Sound pressure dB (A)- Low	35	=
Airflow m3/h- High	1860	=
Airflow m3/h- Mid	1530	=
Airflow m3/h- Low	1200	=
Power Consumption (W)- High	83	=
Power Consumption (W)- Mid	54	=
Power Consumption (W)- Low	31	=
<b>Mechanical - Loads</b>		
Seasonal and Rated Efficiency	-	=
Part Load	-	=
Capacities - Cooling (kW)	14	=
Capacities - Heating (kW)	16	=

## Family Types

Type name:

Search parameters

Parameter	Value	Formula
<b>Energy Analysis</b>		
Energy class	-	=
Capacity	-	=
Rated efficiency	-	=
<b>Visibility</b>		
SERVICE AREA (default)	<input type="checkbox"/>	=
Right Side Clearance (default)	250.0	=
Left Side Clearance (default)	250.0	=
Back Clearance (default)	10.0	=
<b>Other</b>		
Sold separately parts (Drain Pump Kit)	TCB-DP31CE	=
Sold separately parts (Elbow Piping Kit)	TCB-KP23CE	=
Refrigerant Information	R410A	=
Weight (Kg)	39	=
<b>Identity Data</b>		
Article Description	Ceiling	=
Article Type	MMC-UP0481HP-E	=
Base Family Version		=
CB-NL Class		=
Content Supplier URL	www.hcltech.com	= "www.hcltech.com"
Copyright	©Toshiba / HCL	= "©Toshiba / HCL"
Custom	<input checked="" type="checkbox"/>	=
EMCS	4	= "4"
ETIM Article Class	EC001213	= "EC001213"
Family Version		=
GLN		=
GTIN		=
Internal Art. No.		=
MEPcontent Class	HEATPUMP	= "HEATPUMP"
Manufacturer Art. No.	MMC-UP0481HP-E	=
Manufacturer URL	https://www.toshiba-carrier.co.jp/global/	=
Product Line	TCTC	= "TCTC"
Revit Version	2017	= "2017"
Stabu Code		=
Type Image		=
Keynote		=
Model	MMC-UP0481HP-E	=
Manufacturer	Toshiba	= "Toshiba"
Type Comments		=
URL	https://www.toshiba-carrier.co.jp/global/	=
Description	Ceiling	=
Assembly Code		=
Cost		=



# MMC-UP0561HP-E

## Family Types

Type name: MMC-UP0561HP-E

### Search parameters

Parameter	Value	Formula
<b>Materials and Finishes</b>		
Red	Colour RGB-255 000 000	=
White	Colour RGB-255 255 255	=
<b>Electrical</b>		
MOCP (A)	15	=
MCA (A)	1.43	=
Running current-Cooling (A)	1.03	=
Power consumption-Cooling (Kw)	0.111	=
Running current-Heating	-	=
Power consumption-Heating	-	=
Frequency (Hz)	50Hz 220-240V	=
Voltage (V)	60Hz 208-230V	=
Starting current (A)	1.49	=
<b>Dimensions</b>		
Height (mm)	235.0	=
Width (mm)	1586.0	=
Depth (mm)	690.0	=
Piping diameter Gas (mm)	15.9	=
Piping diameter Liquid (mm)	9.5	=
Drain Pipe(mm)	VP20(OD:26mm)	=
Duct diameters(mm)	-	=
<b>Mechanical - Flow</b>		
Static pressure	-	=
Sound pressure dB (A)- High	46	=
Sound pressure dB (A)- Mid	42	=
Sound pressure dB (A)- Low	36	=
Airflow m3/h- High	2040	=
Airflow m3/h- Mid	1650	=
Airflow m3/h- Low	1260	=
Power Consumption (W)- High	111	=
Power Consumption (W)- Mid	63	=
Power Consumption (W)- Low	35	=
<b>Mechanical - Loads</b>		
Seasonal and Rated Efficiency	-	=
Part Load	-	=
Capacities - Cooling (kW)	16	=
Capacities - Heating (kW)	18	=

## Family Types

Type name: MMC-UP0561HP-E

### Search parameters

Parameter	Value	Formula
<b>Energy Analysis</b>		
Energy class	-	=
Capacity	-	=
Rated efficiency	-	=
<b>Visibility</b>		
SERVICE AREA (default)	<input type="checkbox"/>	=
Right Side Clearance (default)	250.0	=
Left Side Clearance (default)	250.0	=
Back Clearance (default)	10.0	=
<b>Other</b>		
Sold separately parts (Drain Pump Kit)	TCB-DP31CE	=
Sold separately parts (Elbow Piping Kit)	TCB-KP23CE	=
Refrigerant Information	R410A	=
Weight (Kg)	39	=
<b>Identity Data</b>		
Article Description	Ceiling	=
Article Type	MMC-UP0561HP-E	=
Base Family Version		=
CB-NL Class		=
Content Supplier URL	www.hcitech.com	= "www.hcitech.com"
Copyright	©Toshiba / HCL	= "©Toshiba / HCL"
Custom	<input checked="" type="checkbox"/>	=
EMCS	4	= "4"
ETIM Article Class	EC001213	= "EC001213"
Family Version		=
GLN		=
GTIN		=
Internal Art. No.		=
MEPcontent Class	HEATPUMP	= "HEATPUMP"
Manufacturer Art. No.	MMC-UP0561HP-E	=
Manufacturer URL	https://www.toshiba-carrier.co.jp/global/	=
Product Line	TCTC	= "TCTC"
Revit Version	2017	= "2017"
Stabu Code		=
Type Image		=
Keynote		=
Model	MMC-UP0561HP-E	=
Manufacturer	Toshiba	= "Toshiba"
Type Comments		=
URL	https://www.toshiba-carrier.co.jp/global/	=
Description	Ceiling	=
Assembly Code		=
Cost		=



**Thank You**