

## 14. RAS\_4MU2VAG\_34

23-05-2019

# RAS\_4MU2VAG\_34

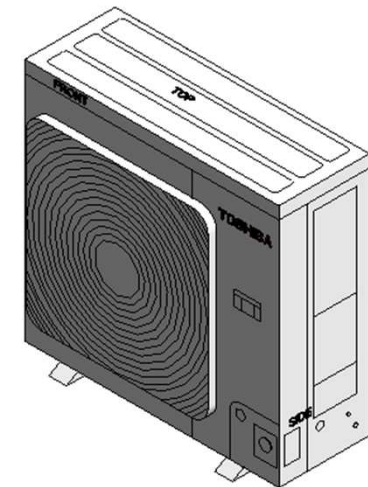
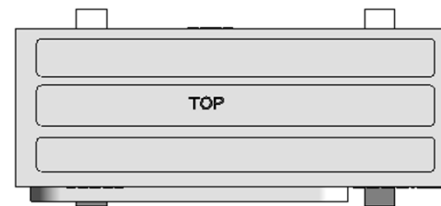
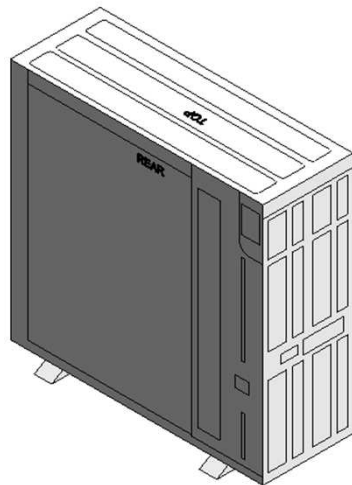
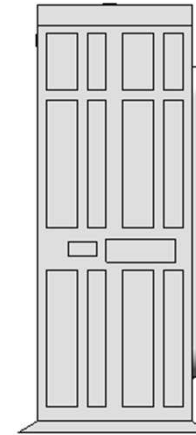
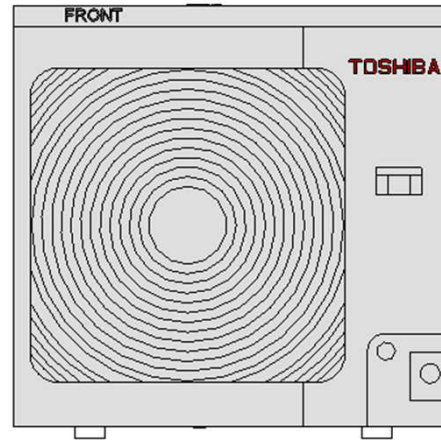
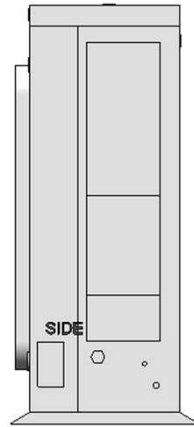

# RAS\_4MU2VAG\_34

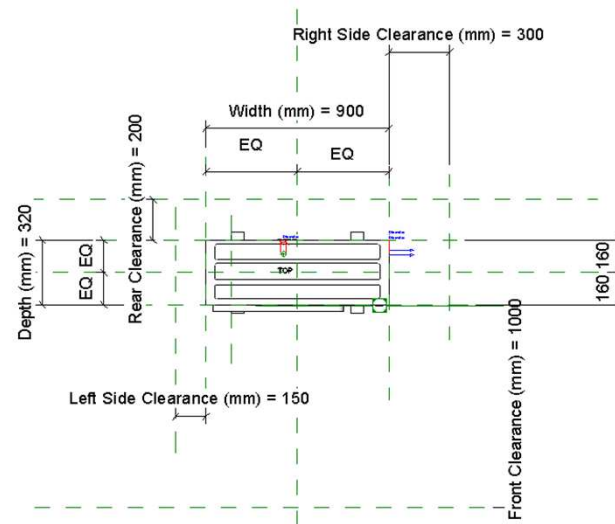
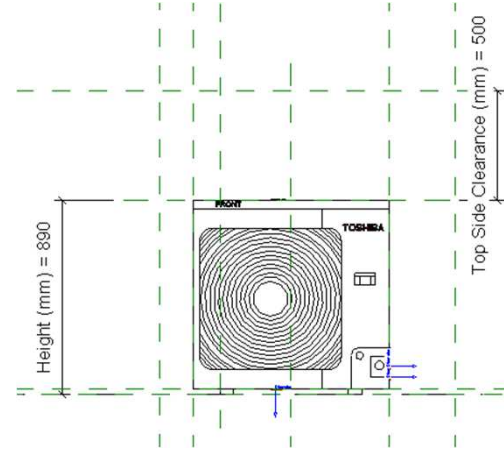

# RAS\_4MU2VAG\_34 Service Area

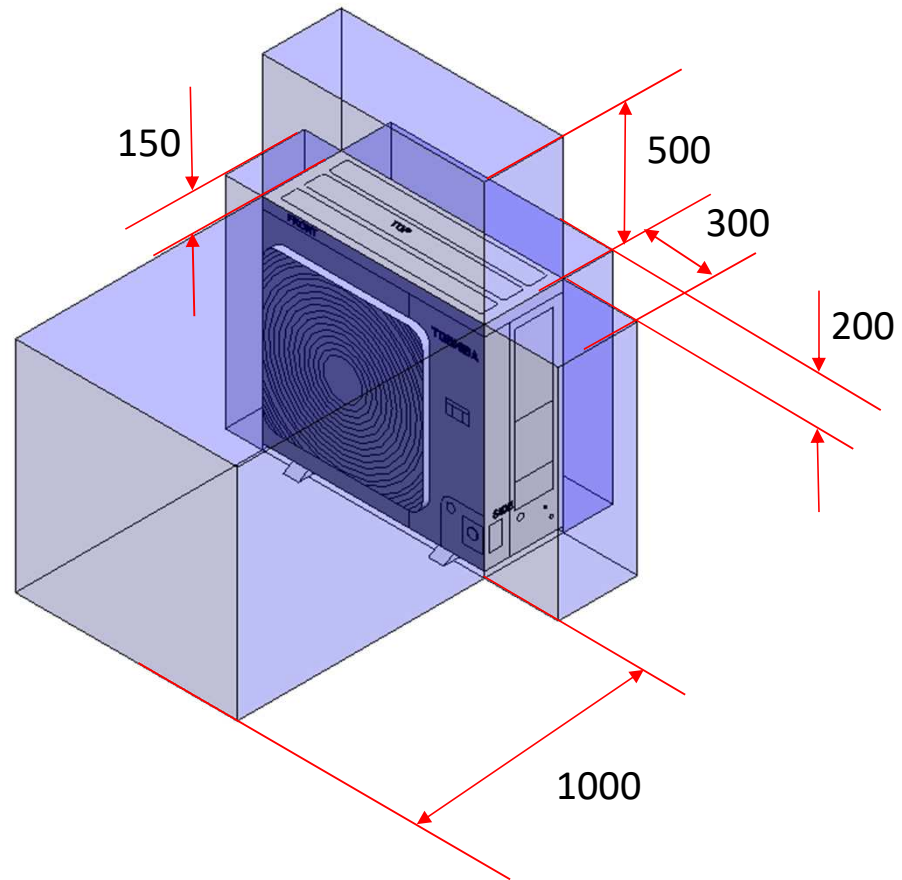

# Electrical Connector

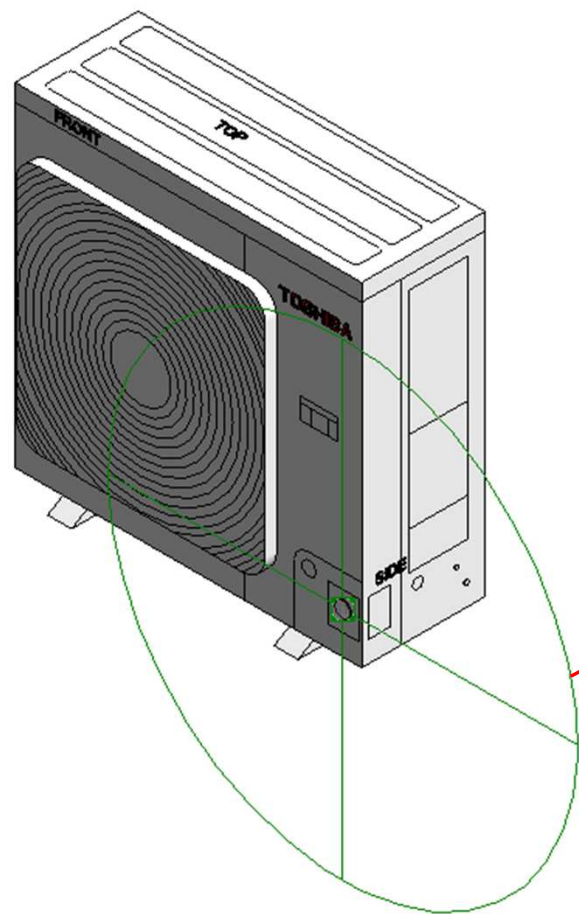

Properties

R

Connector Element (1) Edit Type

Electrical - Loads	
System Type	Power - Unbalanced
Number of Poles	1
Power Factor State	Lagging
Load Classification	Other
Load Sub-Classification Motor	<input type="checkbox"/>
Voltage	0.00 V
Apparent Load Phase 1	0.00 VA
Apparent Load Phase 2	0.00 VA
Apparent Load Phase 3	0.00 VA
Power Factor	1.000000
Identity Data	
Utility	<input type="checkbox"/>
Connector Description	ELECTRICAL CONNECTOR

# Pipe Connectors

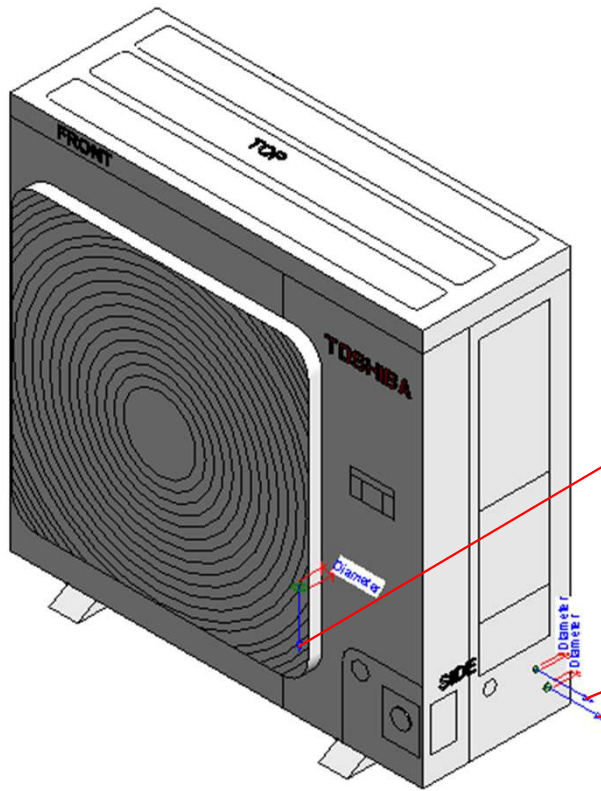

Properties

R

Connector Element (1) Edit Type

Dimensions	
Diameter	25.0
Mechanical	
K Coefficient	0.000000
Flow Factor	0.000000
Flow Configuration	Calculated
Flow Direction	Bidirectional
Loss Method	Not Defined
Allow Slope Adjustments	<input type="checkbox"/>
System Classification	Vent
Mechanical - Flow	
Flow	0.00 L/s
Pressure Drop	0.00 Pa
Identity Data	
Utility	<input type="checkbox"/>
Connector Description	DRAIN PORT

Properties

R

Connector Element (1) Edit Type

Dimensions	
Diameter	9.5
Mechanical	
K Coefficient	0.000000
Flow Factor	0.000000
Flow Configuration	Calculated
Flow Direction	Bidirectional
Loss Method	Not Defined
Allow Slope Adjustments	<input type="checkbox"/>
System Classification	Hydronic Supply
Mechanical - Flow	
Flow	0.00 L/s
Pressure Drop	0.00 Pa
Identity Data	
Utility	<input type="checkbox"/>
Connector Description	HYDRONIC SUPPLY (LIQUID) PORT @ 9.5 mm

Properties

R

Connector Element (1) Edit Type

Dimensions	
Diameter	12.7
Mechanical	
K Coefficient	0.000000
Flow Factor	0.000000
Flow Configuration	Calculated
Flow Direction	Bidirectional
Loss Method	Not Defined
Allow Slope Adjustments	<input type="checkbox"/>
System Classification	Hydronic Return
Mechanical - Flow	
Flow	0.00 L/s
Pressure Drop	0.00 Pa
Identity Data	
Utility	<input type="checkbox"/>
Connector Description	HYDRONIC RETURN (GAS) PORT @ 12.7 mm

# RAS-5M34U2AVG-E

Family Types		
Type name:	RAS-5M34U2AVG-E	
Search parameters		
Parameter	Value	Formula
<b>Materials and Finishes</b>		
Red	Colour RGB-250 000 000	=
White	Colour RGB-255 255 255	=
<b>Electrical</b>		
MOCP (A)	20	=
MCA (A)		=
Running current-Cooling (A)	14.26/13.65/13.07	=
Power consumption-Cooling (Kw)	2980	=
Running current-Heating (A)	13.56/12.97/12.43	=
Power consumption-Heating (Kw)	2833	=
Frequency (Hz)	50Hz	=
Voltage (V)	220V-240V	=
Maximum current A		=
<b>Dimensions</b>		
Height (mm)	890.0	=
Width (mm)	900.0	=
Depth (mm)	320.0	=
Hydronic Supply Diameter (mm)	9.5	=
Hydronic Return Diameter (mm)	12.7	=
Weight (Kg)	78	=
Drain pipe		=
Duct diameters		=
<b>Mechanical - Flow</b>		
Static pressure		=
Sound pressure - Cooling/Heating (dB)	52 / 55	=
Airflow m3/h - Cooling/Heating	3426 / 3666	=
<b>Mechanical - Loads</b>		
Rated Capacity kW- Cooling/Heating	10.0 / 12.0	=
Rated Power Consumption kW - Cooling/Heat	2980 / 1833	=
Rated efficiency EER / COP	3.36 / 4.24	=
<b>Energy Analysis</b>		
Energy class-Cooling/Heating	A++ / A++	=
Seasonal Efficiency-SEER / SCOP	6.31 / 4.08	=
Pdesigh - Cooling/Heating	10.0 / 6.8	=

<b>Visibility</b>		
Service Area (default)	<input type="checkbox"/>	=
Front Clearance (mm) (default)	1000.0	=
Rear Clearance (mm) (default)	200.0	=
Right Side Clearance (mm) (default)	300.0	=
Left Side Clearance (mm) (default)	150.0	=
Top Side Clearance (mm) (default)	500.0	=
<b>Other</b>		
Compressor detail - Type	Hermetic DC twin rotary compressor	=
Compressor detail - Motor output (kW)	2000	=
Operating range - Cooling (°C)	-10 to 46 degC	=
Operating range - Heating (°C)	-15 to 24 degC	=
Refrigerant information	R32	=
<b>Identity Data</b>		
Article Description	Multi R32	=
Article Type	RAS-5M34U2AVG-E	=
Assembly Code		=
Base Family Version		=
CB-NL Class		=
Content Supplier URL	www.hcltech.com	=
Copyright	©Toshiba / HCL	= "©Toshiba / HCL"
Cost		=
Custom	<input type="checkbox"/>	=
Description	Multi R32	=
EMCS	4	= "4"
ETIM Article Class	EC001213	= "EC001213"
Family Version		=
GLN		=
GTIN		=
Internal Art. No.		=
Keynote		=
MEPcontent Class	HEATPUMP	= "HEATPUMP"
Manufacturer	Toshiba	= "Toshiba"
Manufacturer Art. No.	RAS-5M34U2AVG-E	=
Manufacturer URL	https://www.toshiba-carrier.co.jp/global/	=
Model	RAS-5M34U2AVG-E	=
Product Line	TCTC	=
Revit Version		=
Stabu Code		=
Type Comments		=
Type Image		=
URL	https://www.toshiba-carrier.co.jp/global/	=
Watermarked By		=
Wholesaler		=
Wholesaler Art. No.		=



**Thank You**