

VRF_MML1BH_15-24

25-01-2021

VRF_MML1BH_15-24

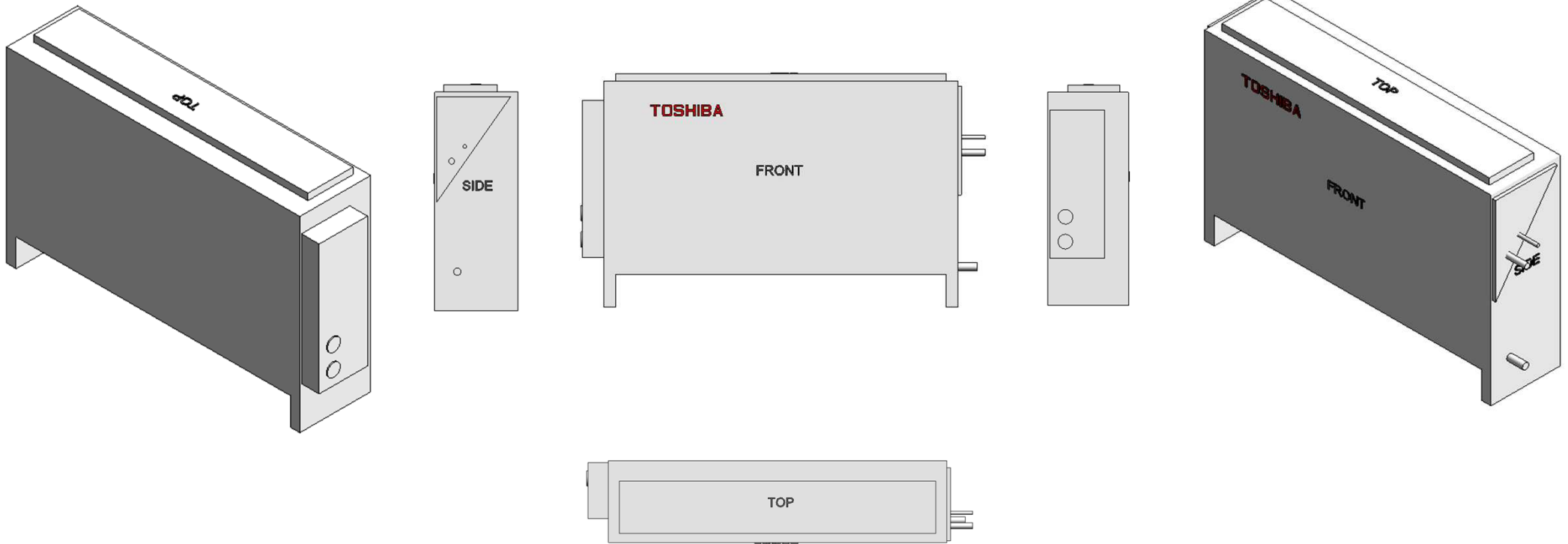

VRF_MML1BH 15-24

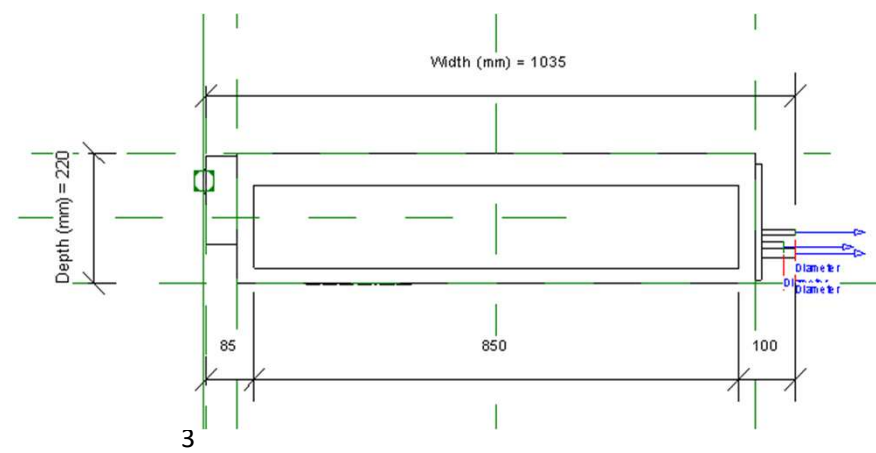
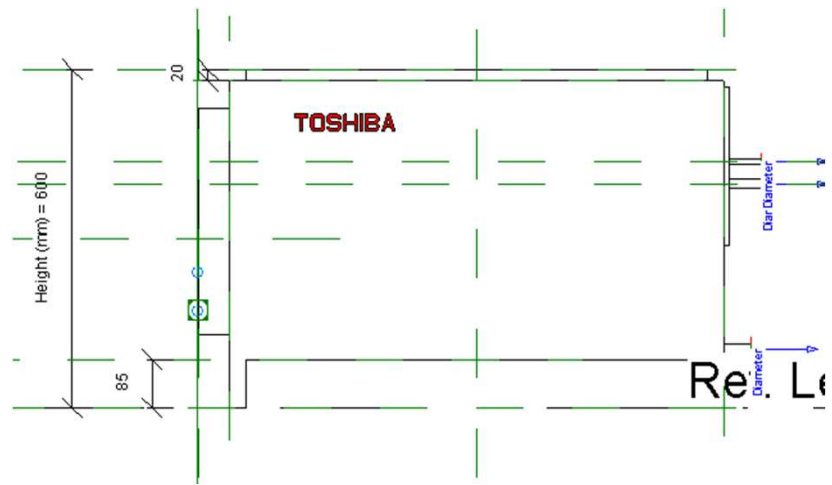
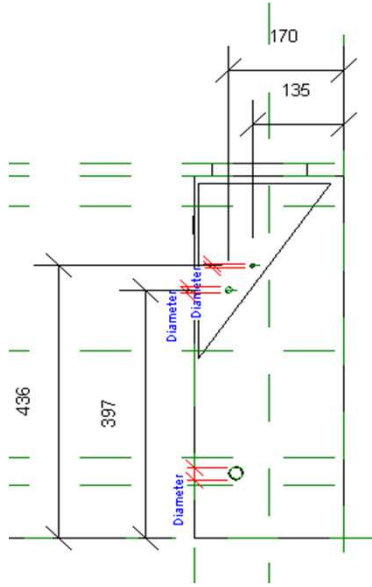

VRF_MML1BH_15-24_Service Area

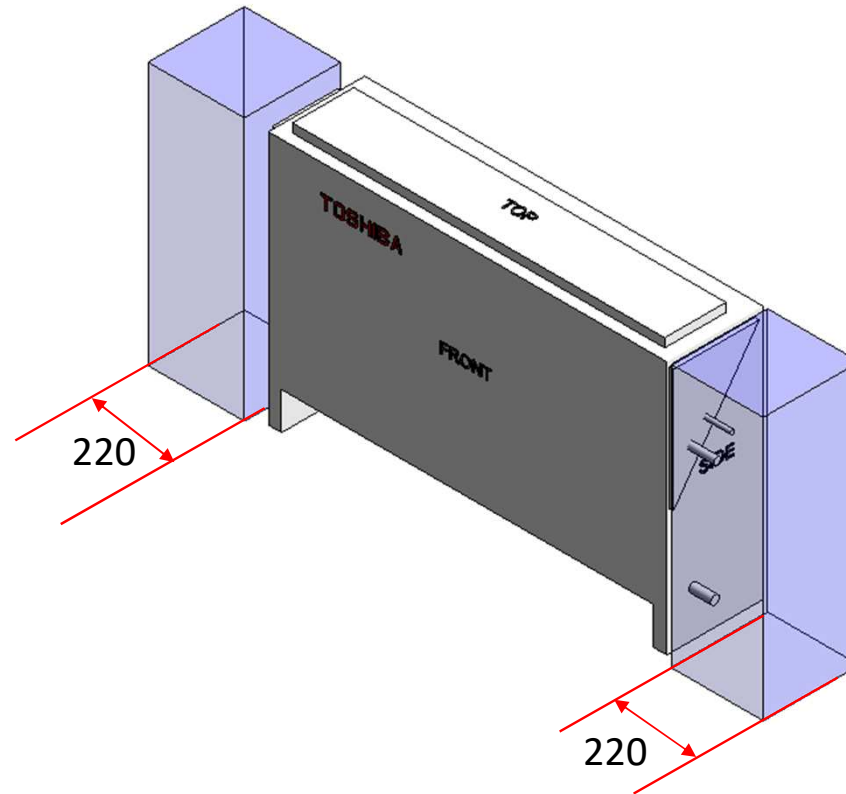

VRF_MML1BH_15-24

Visibility	
Service Area (default)	<input checked="" type="checkbox"/>
Top Clearance (default)	Free
Right Side Clearance (default)	220.0
Left Side Clearance (default)	220.0

Service Clearance ON

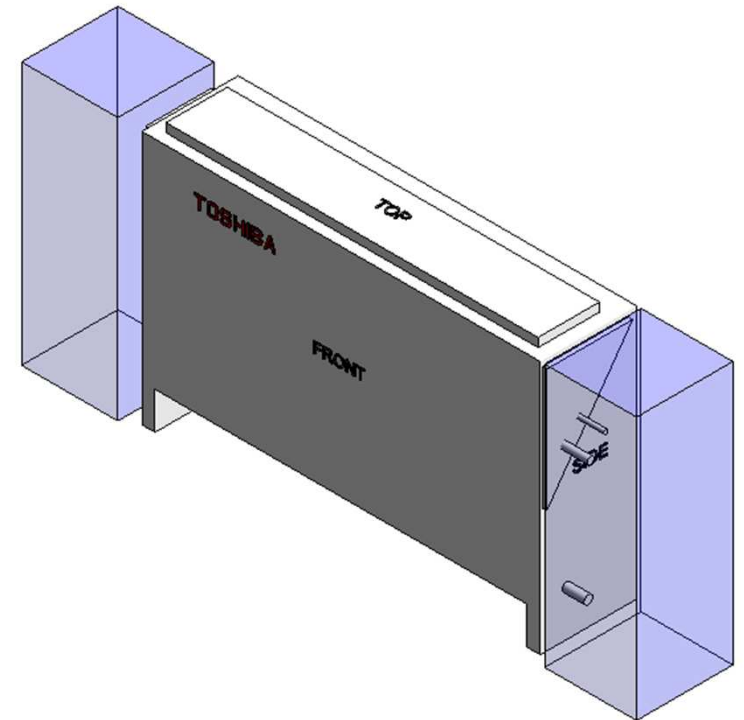

VRF_MML1BH_15-24

Visibility	
Service Area (default)	<input type="checkbox"/>
Top Clearance (default)	Free
Right Side Clearance (default)	220.0
Left Side Clearance (default)	220.0

Service Clearance OFF

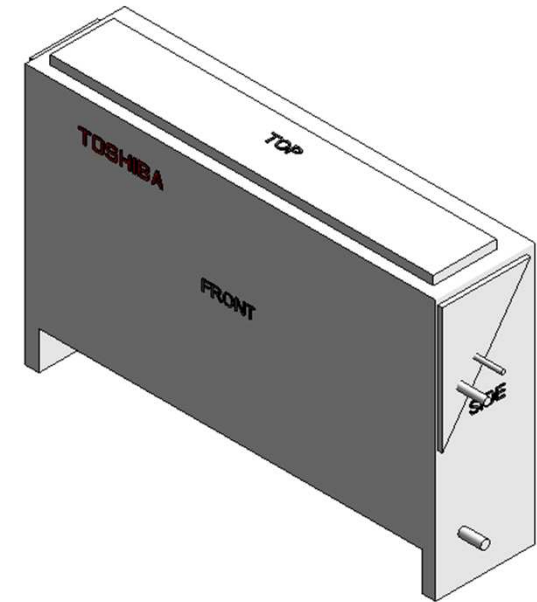

Electrical Connector

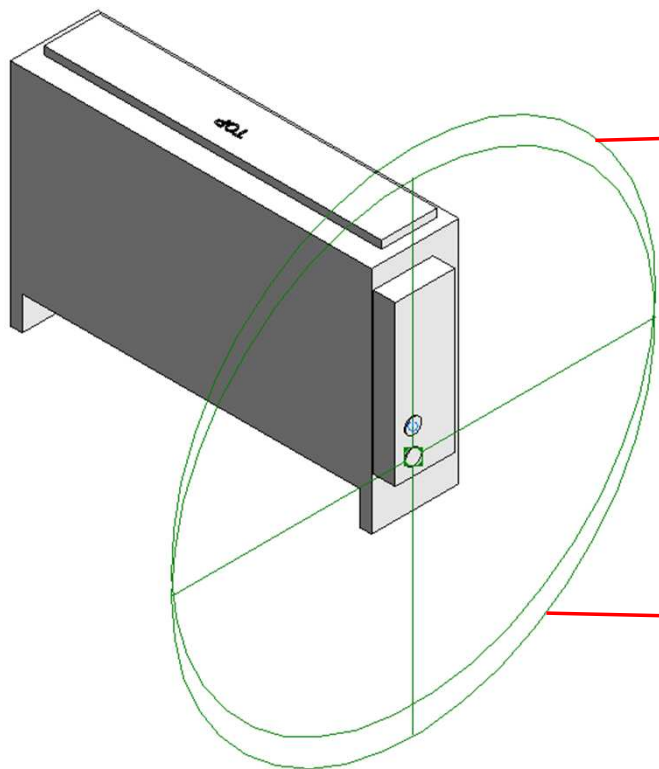

Properties	
R	
Connector Element (1) Edit Type	
Electrical - Loads	
System Type	Controls
Identity Data	
Utility	<input type="checkbox"/>
Connector Description	CONTROL CABLE PORT

Properties	
R	
Connector Element (1) Edit Type	
Electrical - Loads	
System Type	Power - Unbalanced
Number of Poles	1
Power Factor State	Lagging
Load Classification	Other
Load Sub-Classification Motor	<input type="checkbox"/>
Voltage	0.00 V
Apparent Load Phase 1	0.00 VA
Apparent Load Phase 2	0.00 VA
Apparent Load Phase 3	0.00 VA
Power Factor	1.000000
Identity Data	
Utility	<input type="checkbox"/>
Connector Description	ELECTRICAL CONNECTOR

Pipe Connectors

Properties	
R	
Connector Element (1) Edit	
Dimensions	
Diameter	12.7
Mechanical	
K Coefficient	0.000000
Flow Factor	0.000000
Flow Configuration	Calculated
Flow Direction	Out
Loss Method	Not Defined
Allow Slope Adjustments	<input type="checkbox"/>
System Classification	Hydronic Return
Mechanical - Flow	
Flow	0.00 L/s
Pressure Drop	0.00 Pa
Identity Data	
Utility	<input type="checkbox"/>
Connector Description	HYDRONIC RETURN (GAS) PORT @ 12.7 mm

Properties	
R	
Connector Element (1) Edit	
Dimensions	
Diameter	15.9
Mechanical	
K Coefficient	0.000000
Flow Factor	0.000000
Flow Configuration	Calculated
Flow Direction	Out
Loss Method	Not Defined
Allow Slope Adjustments	<input type="checkbox"/>
System Classification	Hydronic Return
Mechanical - Flow	
Flow	0.00 L/s
Pressure Drop	0.00 Pa
Identity Data	
Utility	<input type="checkbox"/>
Connector Description	HYDRONIC RETURN (GAS) PORT @ 15.9 mm

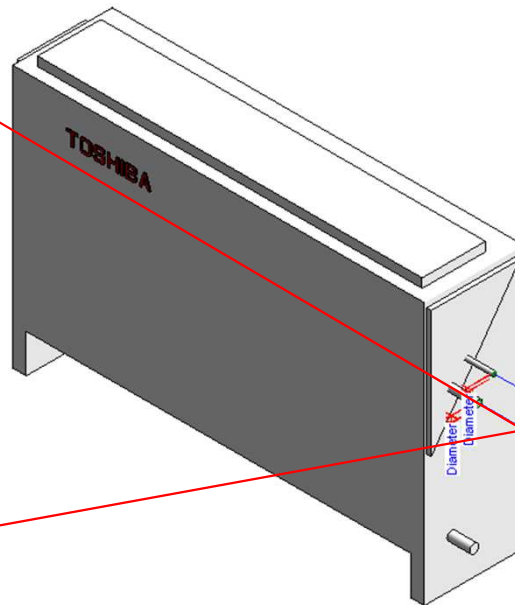

Properties	
R	
Connector Element (1) Edit	
Dimensions	
Diameter	6.4
Mechanical	
K Coefficient	0.000000
Flow Factor	0.000000
Flow Configuration	Calculated
Flow Direction	In
Loss Method	Not Defined
Allow Slope Adjustments	<input type="checkbox"/>
System Classification	Hydronic Supply
Mechanical - Flow	
Flow	0.00 L/s
Pressure Drop	0.00 Pa
Identity Data	
Utility	<input type="checkbox"/>
Connector Description	HYDRONIC SUPPLY (LIQUID) PORT @ 6.4mm

Properties	
R	
Connector Element (1) Edit	
Dimensions	
Diameter	9.5
Mechanical	
K Coefficient	0.000000
Flow Factor	0.000000
Flow Configuration	Calculated
Flow Direction	Out
Loss Method	Not Defined
Allow Slope Adjustments	<input type="checkbox"/>
System Classification	Hydronic Return
Mechanical - Flow	
Flow	0.00 L/s
Pressure Drop	0.00 Pa
Identity Data	
Utility	<input type="checkbox"/>
Connector Description	HYDRONIC RETURN (GAS) PORT @ 9.5 mm

Drain Pipe Connector

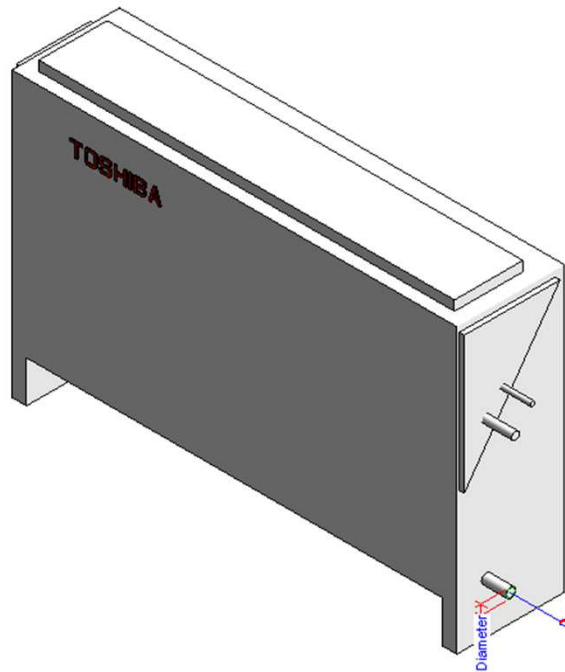

Properties	
	
Connector Element (1) ▼ Edit T	
Dimensions	
Diameter	20.0
Mechanical	
K Coefficient	0.000000
Flow Factor	0.000000
Flow Configuration	Calculated
Flow Direction	Out
Loss Method	Not Defined
Allow Slope Adjustments	<input type="checkbox"/>
System Classification	Vent
Mechanical - Flow	
Flow	0.00 L/s
Pressure Drop	0.00 Pa
Identity Data	
Utility	<input type="checkbox"/>
Connector Description	DRAIN PORT

MML-UP0151BH-E

Family Types

Type name: MML-UP0151BH-E

Search parameters

Parameter	Value	Formula
Materials and Finishes		
Red	Colour RGB-255 000 000	=
White	Colour RGB-255 255 255	=
Electrical		
MOCP (A)	15	=
MCA (A)	0.65	=
Running current-Cooling (A)	0.45	=
Power consumption-Cooling (Kw)	0.09	=
Running current-Heating	-	=
Power consumption-Heating	-	=
Frequency (Hz)	50Hz 220-240V	=
Voltage (V)	60Hz 220V	=
Starting current (A)	0.8	=
Dimensions		
Height (mm)	600.0	=
Width (mm)	1035.0	=
Depth (mm)	220.0	=
Piping diameter Gas (mm)	12.7	=
Piping diameter Liquid (mm)	6.4	=
Drain pipe(mm)	20	=
Duct diameters(mm)	-	=
Mechanical - Flow		
Static pressure Pa	-	=
Sound pressure (dB)- High	36	=
Sound pressure (dB)- Mid	34	=
Sound pressure (dB)- Low	32	=
Airflow m3/h- High	740	=
Airflow m3/h- Mid	600	=
Airflow m3/h- Low	490	=
Power Consumption W- High	90	=
Power Consumption W- Mid	75	=
Power Consumption W- Low	62	=
Mechanical - Loads		
Seasonal and Rated Efficiency	-	=
Part Load	-	=
Capacities KW - Cooling	4.5	=
Capacities KW - Heating	5	=
Energy Analysis		
Energy class	-	=
Capacity	-	=
Rated efficiency	-	=

Family Types

Type name: MML-UP0151BH-E

Search parameters

Parameter	Value	Formula
Visibility		
Service Area (default)	<input type="checkbox"/>	=
Top Clearance (default)	Free	=
Right Side Clearance (default)	220.0	=
Left Side Clearance (default)	220.0	=
Other		
Connectivity	-	=
Compressor detail-Type	-	=
Compressor detail-Motor output kW	-	=
Refrigerant information	R410A	=
Weight (Kg)	29	=
Identity Data		
Article Description	Concealed console	=
Article Type	MML-UP0151BH-E	=
Base Family Version		=
CB-NL Class		=
Content Supplier URL	www.hcitech.com	=
Copyright	©Toshiba / HCL	= "©Toshiba / HCL"
Custom	<input checked="" type="checkbox"/>	=
EMCS	4	= "4"
ETIM Article Class	EC001213	= "EC001213"
Family Version		=
GLN		=
GTIN		=
Internal Art. No.		=
MEPcontent Class	HEATPUMP	= "HEATPUMP"
Manufacturer Art. No.	MML-UP0151BH-E	=
Manufacturer URL	https://www.toshiba-carrier.co.jp/global	=
Product Line	TCC	= "TCC"
Revit Version	2017	= "2017"
Stabu Code		=
Type Image		=
Keynote		=
Model	MML-UP0151BH-E	=
Manufacturer	Toshiba	= "Toshiba"
Type Comments		=
URL	https://www.toshiba-carrier.co.jp/global	=
Description	Concealed console	=
Assembly Code		=
Cost		=
Watermarked By		=
Wholesaler		=
Wholesaler Art. No.		=

MML-UP0181BH-E

Family Types

Type name: MML-UP0181BH-E

Search parameters

Parameter	Value	Formula
Materials and Finishes		
Red	Colour RGB-255 000 000	=
White	Colour RGB-255 255 255	=
Electrical		
MOCP (A)	15	=
MCA (A)	0.65	=
Running current-Cooling (A)	0.45	=
Power consumption-Cooling (Kw)	0.09	=
Running current-Heating	-	=
Power consumption-Heating	-	=
Frequency (Hz)	50Hz 220-240V	=
Voltage (V)	60Hz 220V	=
Starting current (A)	-	=
Dimensions		
Height (mm)	600.0	=
Width (mm)	1035.0	=
Depth (mm)	220.0	=
Piping diameter Gas (mm)	12.7	=
Piping diameter Liquid (mm)	6.4	=
Drain pipe(mm)	20	=
Duct diameters(mm)	-	=
Mechanical - Flow		
Static pressure Pa	-	=
Sound pressure (dB)- High	36	=
Sound pressure (dB)- Mid	34	=
Sound pressure (dB)- Low	32	=
Airflow m3/h- High	740	=
Airflow m3/h- Mid	600	=
Airflow m3/h- Low	490	=
Power Consumption W- High	90	=
Power Consumption W- Mid	75	=
Power Consumption W- Low	62	=
Mechanical - Loads		
Seasonal and Rated Efficiency	-	=
Part Load	-	=
Capacities KW - Cooling	5.6	=
Capacities KW - Heating	6.3	=
Energy Analysis		
Energy class	-	=
Capacity	-	=
Rated efficiency	-	=

Family Types

Type name: MML-UP0181BH-E

Search parameters

Parameter	Value	Formula
Visibility		
Service Area (default)	<input type="checkbox"/>	=
Top Clearance (default)	Free	=
Right Side Clearance (default)	220.0	=
Left Side Clearance (default)	220.0	=
Other		
Connectivity	-	=
Compressor detail-Type	-	=
Compressor detail-Motor output kW	-	=
Refrigerant information	R410A	=
Weight (Kg)	29	=
Identity Data		
Article Description	Concealed console	=
Article Type	MML-UP0181BH-E	=
Base Family Version		=
CB-NL Class		=
Content Supplier URL	www.hcltech.com	=
Copyright	©Toshiba / HCL	= "©Toshiba / HCL"
Custom	<input checked="" type="checkbox"/>	=
EMCS	4	= "4"
ETIM Article Class	EC001213	= "EC001213"
Family Version		=
GLN		=
GTIN		=
Internal Art. No.		=
MEPcontent Class	HEATPUMP	= "HEATPUMP"
Manufacturer Art. No.	MML-UP0181BH-E	=
Manufacturer URL	https://www.toshiba-carrier.co.jp/global	=
Product Line	TCC	= "TCC"
Revit Version	2017	= "2017"
Stabu Code		=
Type Image		=
Keynote		=
Model	MML-UP0181BH-E	=
Manufacturer	Toshiba	= "Toshiba"
Type Comments		=
URL	https://www.toshiba-carrier.co.jp/global	=
Description	Concealed console	=
Assembly Code		=
Cost		=
Watermarked By		=
Wholesaler		=
Wholesaler Art. No.		=

MML-UP0241BH-E

Family Types

Type name: MML-UP0241BH-E

Search parameters

Parameter	Value	Formula
Materials and Finishes		
Red	Colour RGB-255 000 000	=
White	Colour RGB-255 255 255	=
Electrical		
MOCP (A)	15	=
MCA (A)	0.66	=
Running current-Cooling (A)	0.46	=
Power consumption-Cooling (Kw)	0.095	=
Running current-Heating	-	=
Power consumption-Heating	-	=
Frequency (Hz)	50Hz 220-240V	=
Voltage (V)	60Hz 220V	=
Starting current (A)	1	=
Dimensions		
Height (mm)	600.0	=
Width (mm)	1035.0	=
Depth (mm)	220.0	=
Piping diameter Gas (mm)	15.9	=
Piping diameter Liquid (mm)	9.5	=
Drain pipe(mm)	20	=
Duct diameters(mm)	-	=
Mechanical - Flow		
Static pressure Pa	0	=
Sound pressure (dB)- High	42	=
Sound pressure (dB)- Mid	37	=
Sound pressure (dB)- Low	33	=
Airflow m3/h- High	950	=
Airflow m3/h- Mid	790	=
Airflow m3/h- Low	640	=
Power Consumption W- High	95	=
Power Consumption W- Mid	80	=
Power Consumption W- Low	67	=
Mechanical - Loads		
Seasonal and Rated Efficiency	-	=
Part Load	-	=
Capacities KW - Cooling	7.1	=
Capacities KW - Heating	8	=
Energy Analysis		
Energy class	-	=
Capacity	-	=
Rated efficiency	-	=

Family Types

Type name: MML-UP0241BH-E

Search parameters

Parameter	Value	Formula
Visibility		
Service Area (default)	<input type="checkbox"/>	=
Top Clearance (default)	Free	=
Right Side Clearance (default)	220.0	=
Left Side Clearance (default)	220.0	=
Other		
Connectivity	-	=
Compressor detail-Type	-	=
Compressor detail-Motor output kW	-	=
Refrigerant information	R410A	=
Weight (Kg)	29	=
Identity Data		
Article Description	Concealed console	=
Article Type	MML-UP0241BH-E	=
Base Family Version		=
CB-NL Class		=
Content Supplier URL	www.hcltech.com	=
Copyright	©Toshiba / HCL	= "©Toshiba / HCL"
Custom	<input checked="" type="checkbox"/>	=
EMCS	4	= "4"
ETIM Article Class	EC001213	= "EC001213"
Family Version		=
GLN		=
GTIN		=
Internal Art. No.		=
MEPcontent Class	HEATPUMP	= "HEATPUMP"
Manufacturer Art. No.	MML-UP0241BH-E	=
Manufacturer URL	https://www.toshiba-carrier.co.jp/global	=
Product Line	TCC	= "TCC"
Revit Version	2017	= "2017"
Stabu Code		=
Type Image		=
Keynote		=
Model	MML-UP0241BH-E	=
Manufacturer	Toshiba	= "Toshiba"
Type Comments		=
URL	https://www.toshiba-carrier.co.jp/global	=
Description	Concealed console	=
Assembly Code		=
Cost		=
Watermarked By		=
Wholesaler		=
Wholesaler Art. No.		=



Thank You