



**HCL**

A2W\_F21S\_11

23-02-2021

# A2W\_F21S\_11

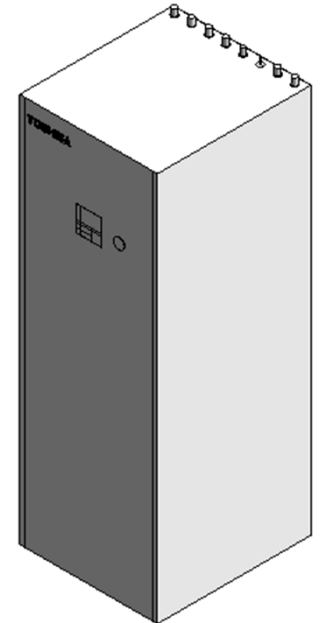
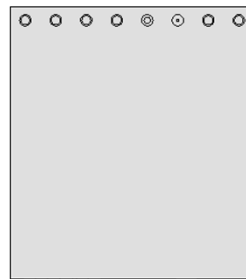
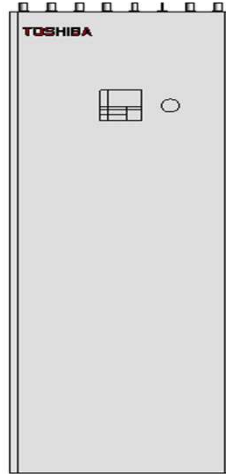
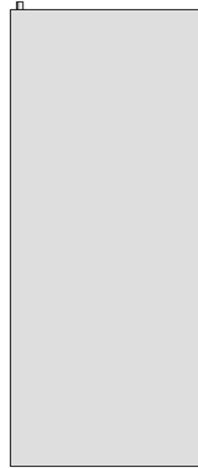
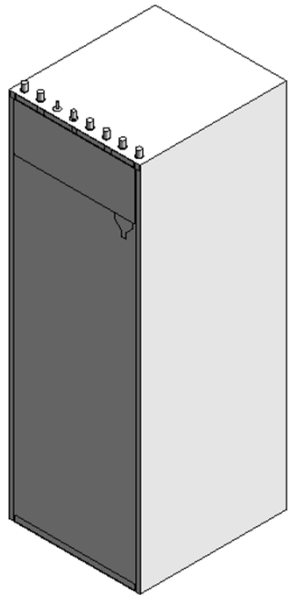

# A2W\_F21S\_11

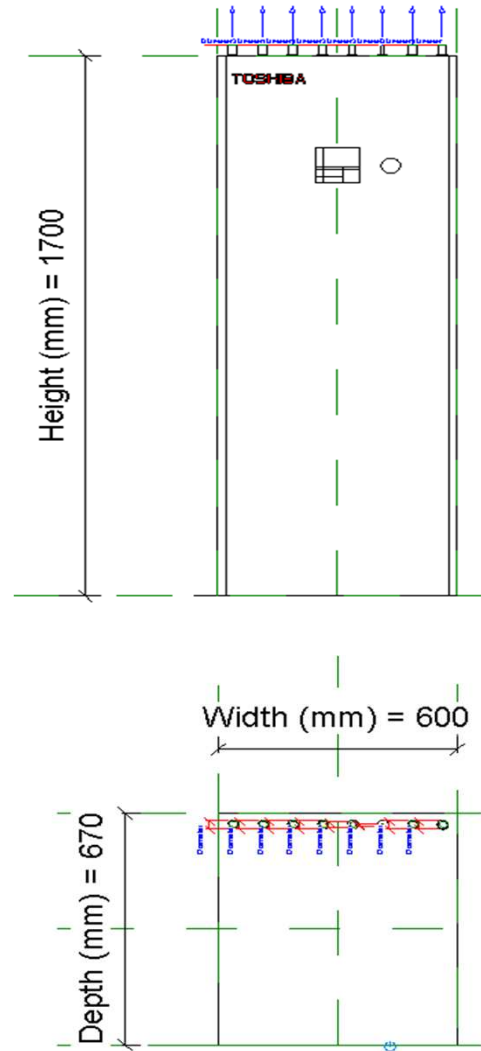

# A2W\_F21S\_11\_Service Area

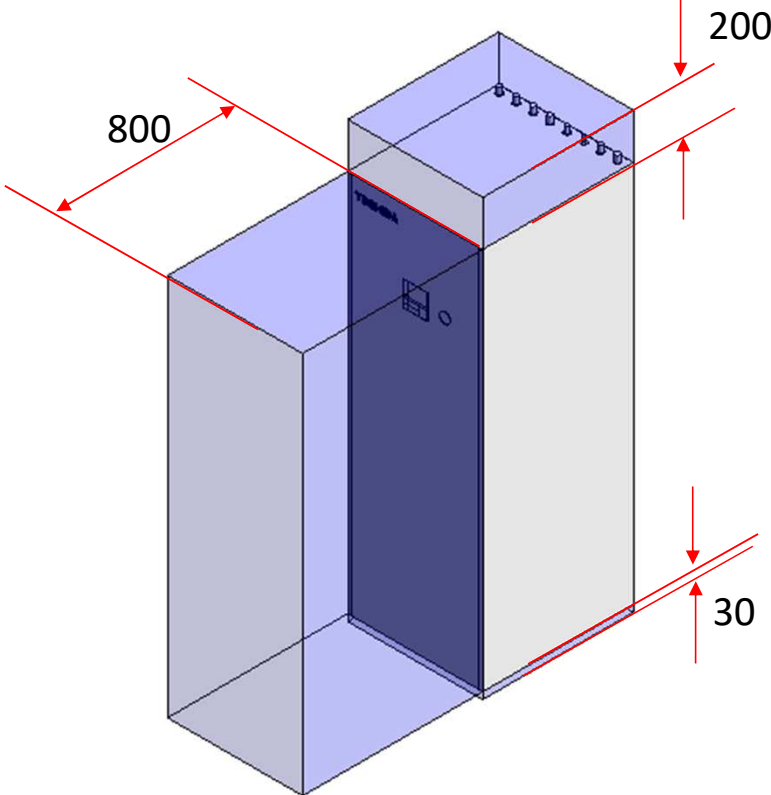

# A2W\_F21S\_11

Visibility	
Service Area (default)	<input checked="" type="checkbox"/>
Top Clearance (default)	200
Front Clearance (default)	800.0
Bottom Clearance (default)	30.0

Service Clearance ON

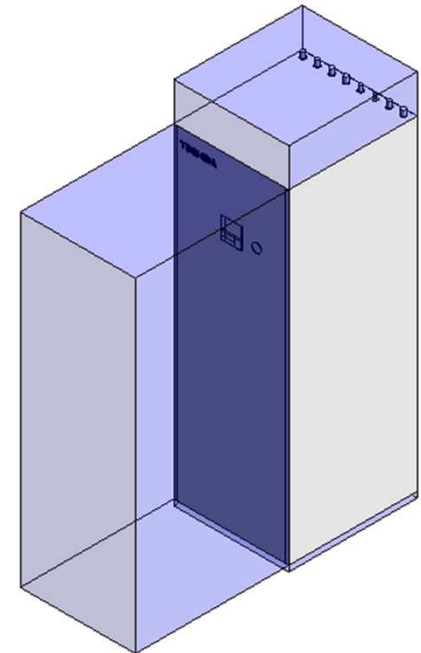

# A2W\_F21S\_11

Visibility	
Service Area (default)	<input type="checkbox"/>
Top Clearance (default)	200
Front Clearance (default)	800.0
Bottom Clearance (default)	30.0

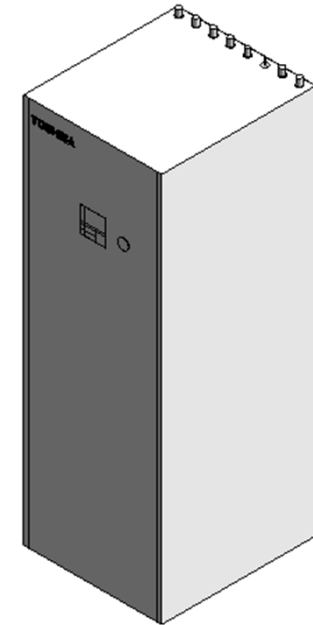

Service Clearance OFF

# Electrical Connector

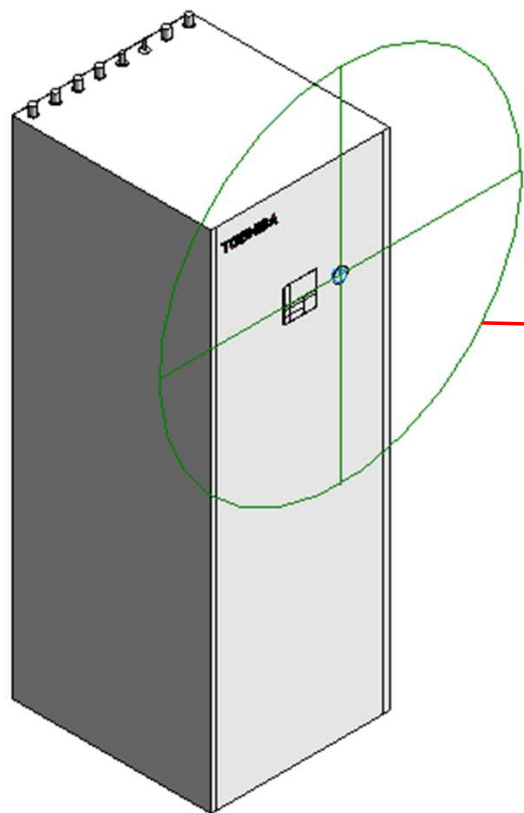

**Properties** [X]

**R**

Connector Element (1) [v] [Edit Type]

Electrical - Loads ^

System Type	Controls
-------------	----------

Identity Data ^

Utility	<input type="checkbox"/>
Connector Description	Pressure Guage

# Pipe Connectors

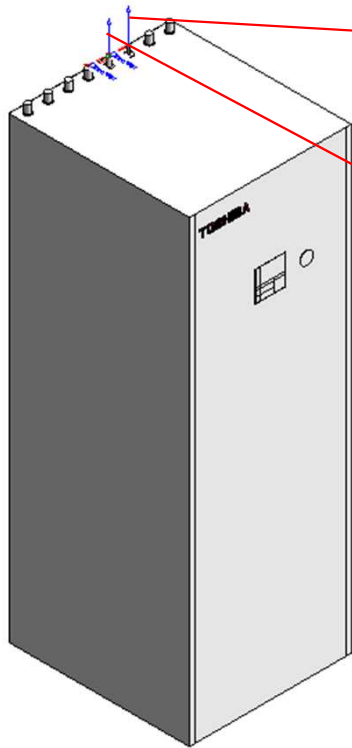

Properties	
Connector Element (1) <span>▼</span> <span>🔍 Edit T</span>	
Dimensions	
Diameter	6.4
Mechanical	
K Coefficient	0.000000
Flow Factor	0.000000
Flow Configuration	Calculated
Flow Direction	In
Loss Method	Not Defined
Allow Slope Adjust...	<input type="checkbox"/>
System Classification	Hydronic Supply
Mechanical - Flow	
Flow	0.00 L/s
Pressure Drop	0.00 Pa
Identity Data	
Utility	<input type="checkbox"/>
Connector Descripti...	Refrigerant Piping diameter-Liquid side

Properties	
	
Connector Element (1) <span>▼</span> <span>🔍 Edit</span>	
Dimensions	
Diameter	15.9
Mechanical	
K Coefficient	0.000000
Flow Factor	0.000000
Flow Configuration	Calculated
Flow Direction	Out
Loss Method	Not Defined
Allow Slope Adjust...	<input type="checkbox"/>
System Classification	Hydronic Return
Mechanical - Flow	
Flow	0.00 L/s
Pressure Drop	0.00 Pa
Identity Data	
Utility	<input type="checkbox"/>
Connector Descripti...	Refrigerant Piping diameter-Gas side



# Pipe Connectors

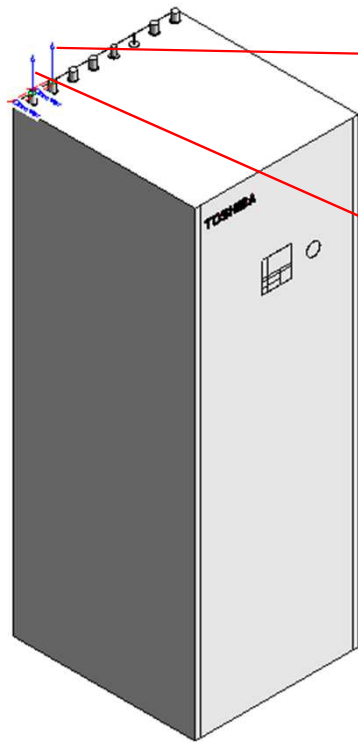

Properties	
<b>R</b>	
Connector Element (1) <span style="float: right;">Edit T</span>	
Dimensions	
Diameter	22.0
Mechanical	
K Coefficient	0.000000
Flow Factor	0.000000
Flow Configuration	Calculated
Flow Direction	Out
Loss Method	Not Defined
Allow Slope Adjustments	<input type="checkbox"/>
System Classification	Domestic Hot Water
Mechanical - Flow	
Fixture Units	0.000000
Flow	0.00 L/s
Pressure Drop	0.00 Pa
Identity Data	
Utility	<input type="checkbox"/>
Connector Description	Hot domestic water flow

Properties	
<b>R</b>	
Connector Element (1) <span style="float: right;">Edit T</span>	
Dimensions	
Diameter	22.0
Mechanical	
K Coefficient	0.000000
Flow Factor	0.000000
Flow Configuration	Calculated
Flow Direction	In
Loss Method	Not Defined
Allow Slope Adjustments	<input type="checkbox"/>
System Classification	Domestic Cold Water
Mechanical - Flow	
Fixture Units	0.000000
Flow	0.00 L/s
Pressure Drop	0.00 Pa
Identity Data	
Utility	<input type="checkbox"/>
Connector Description	Cold domestic water in

# Pipe Connectors

Properties	
<b>R</b>	
Connector Element (1) Edit	
Dimensions	
Diameter	22.0
Mechanical	
K Coefficient	0.000000
Flow Factor	0.000000
Flow Configuration	Calculated
Flow Direction	Out
Loss Method	Not Defined
Allow Slope Adjustments	<input type="checkbox"/>
System Classification	Hydronic Return
Mechanical - Flow	
Flow	0.00 L/s
Pressure Drop	0.00 Pa
Identity Data	
Utility	<input type="checkbox"/>
Connector Description	Zone 1 heating return

Properties	
<b>R</b>	
Connector Element (1) Edit	
Dimensions	
Diameter	22.0
Mechanical	
K Coefficient	0.000000
Flow Factor	0.000000
Flow Configuration	Calculated
Flow Direction	In
Loss Method	Not Defined
Allow Slope Adjustments	<input type="checkbox"/>
System Classification	Hydronic Supply
Mechanical - Flow	
Flow	0.00 L/s
Pressure Drop	0.00 Pa
Identity Data	
Utility	<input type="checkbox"/>
Connector Description	Zone 1 heating flow

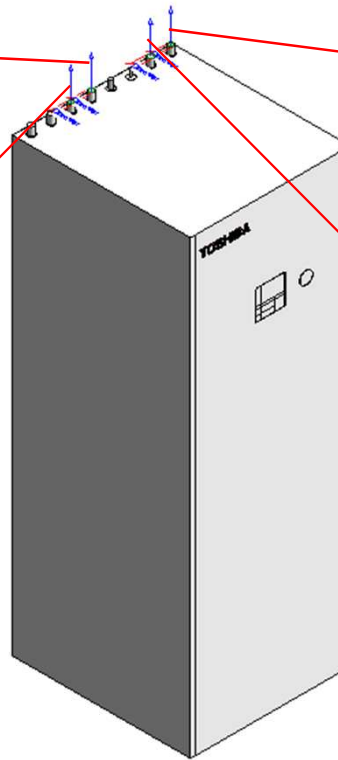

Properties	
<b>R</b>	
Connector Element (1) Edit	
Dimensions	
Diameter	22.0
Mechanical	
K Coefficient	0.000000
Flow Factor	0.000000
Flow Configuration	Calculated
Flow Direction	In
Loss Method	Not Defined
Allow Slope Adjustments	<input type="checkbox"/>
System Classification	Hydronic Supply
Mechanical - Flow	
Flow	0.00 L/s
Pressure Drop	0.00 Pa
Identity Data	
Utility	<input type="checkbox"/>
Connector Description	Zone 2 heating flow

Properties	
<b>R</b>	
Connector Element (1) Edit	
Dimensions	
Diameter	22.0
Mechanical	
K Coefficient	0.000000
Flow Factor	0.000000
Flow Configuration	Calculated
Flow Direction	Out
Loss Method	Not Defined
Allow Slope Adjustments	<input type="checkbox"/>
System Classification	Hydronic Return
Mechanical - Flow	
Flow	0.00 L/s
Pressure Drop	0.00 Pa
Identity Data	
Utility	<input type="checkbox"/>
Connector Description	Zone 2 heating return

# HWT-1101F21SM3W-E

## Family Types

Type name: HWT-1101F21SM3W-E

Search parameters

Parameter	Value	Formula
<b>Materials and Finishes</b>		
Red	Colour RGB-255 000 000	=
White	Colour RGB-255 255 255	=
<b>Electrical</b>		
MOCP	16	=
MCA	-	=
Running current-Cooling (A)	-	=
Power consumption-Cooling (Kw)	2.86	=
Running current-Heating (A)	-	=
Power consumption-Heating (kW)	2.39	=
Frequency (Hz)	50Hz	=
Voltage (V)	220-240V	=
Maximum current	13	=
<b>Dimensions</b>		
Height (mm)	1700.0	=
Width (mm)	600.0	=
Depth (mm)	670.0	=
Piping diameter Gas (mm)	15.9	=
Piping diameter Liquid (mm)	6.4	=
Water Piping diameter - Inlet/Outlet	Φ22 compression fitting	=
Drain piping diameter	-	=
<b>Mechanical - Flow</b>		
Static pressure Pa	-	=
Sound Power level (dB(A))	1zone 42dB(A) / 2zone 44dB(A)	=
<b>Mechanical - Loads</b>		
Rated Capacity kW - Cooling/Heating	8.0 / 11.0	=
Rated Power Consumption kW - Cooling/Heating	2.86/2.39	=
Rated efficiency-EER / COP	2.80 / 4.60	=
<b>Energy Analysis</b>		
Energy efficiency class - Low temp.	-	=
Seasonal space heating energy efficiency (ηs)	142%	=
Rated water flow rate-L/min	-	=
Back up heater capacity kW	3	=

## Family Types

Type name: HWT-1101F21SM3W-E

Search parameters

Parameter	Value	Formula
<b>Visibility</b>		
Service Area (default)	<input type="checkbox"/>	=
Top Clearance (default)	200	=
Front Clearance (default)	800.0	=
Bottom Clearance (default)	30.0	=
<b>Other</b>		
Operating range degC - Cooling	18 - 32	=
Operating range degC-Heating	5 - 32	=
Operating range degC-Hot water	5 - 32	=
Compressor detail (Type)	-	=
Compressor detail (Motor output W)	-	=
Refrigerant information	R32	=
Weight (Kg)	1Zone: 157kg 2Zone:162kg	=
<b>Identity Data</b>		
Article Description	ESTIA R32	=
Article Type	HWT-1101F21SM3W-E	=
Base Family Version		=
CB-NL Class		=
Content Supplier URL	www.hcltech.com	=
Copyright	©Toshiba / HCL	"©Toshiba / HCL"
Custom	<input checked="" type="checkbox"/>	=
EMCS	4	"4"
ETIM Article Class	EC001213	"EC001213"
Family Version		=
GLN		=
GTIN		=
Internal Art. No.		=
MEPcontent Class	HEATPUMP	"HEATPUMP"
Manufacturer Art. No.	HWT-1101F21SM3W-E	=
Manufacturer URL	https://www.toshiba-carrier.co.jp/global/	=
Product Line	TCAE	"TCAE"
Revit Version	2017	"2017"
Stabu Code		=
Type Image		=
Keynote		=
Model	HWT-1101F21SM3W-E	=
Manufacturer	Toshiba	"Toshiba"
Type Comments		=
URL	https://www.toshiba-carrier.co.jp/global/	=
Description	ESTIA R32	=
Assembly Code		=
Cost		=
Watermarked By		=

# HWT-1101F21ST6W-E

## Family Types

Type name: HWT-1101F21ST6W-E

Search parameters

Parameter	Value	Formula
<b>Materials and Finishes</b>		
Red	Colour RGB-255 000 000	=
White	Colour RGB-255 255 255	=
<b>Electrical</b>		
MOCP	16	=
MCA	-	=
Running current-Cooling (A)	-	=
Power consumption-Cooling (Kw)	2.86	=
Running current-Heating (A)	-	=
Power consumption-Heating (kW)	2.39	=
Frequency (Hz)	50Hz	=
Voltage (V)	380-415V	=
Maximum current	13	=
<b>Dimensions</b>		
Height (mm)	1700.0	=
Width (mm)	600.0	=
Depth (mm)	670.0	=
Piping diameter Gas (mm)	15.9	=
Piping diameter Liquid (mm)	6.4	=
Water Piping diameter - Inlet/Outlet	Ø22 compression fitting	=
Drain piping diameter	-	=
<b>Mechanical - Flow</b>		
Static pressure Pa	-	=
Sound Power level (dB(A))	1zone 42dB(A) / 2zone 44dB(A)	=
<b>Mechanical - Loads</b>		
Rated Capacity kW - Cooling/Heating	8.0 / 11.0	=
Rated Power Consumption kW - Cooling/Heating	2.86/2.39	=
Rated efficiency-EER / COP	2.80 / 4.60	=
<b>Energy Analysis</b>		
Energy efficiency class - Low temp.	-	=
Seasonal space heating energy efficiency (ηs)	142%	=
Rated water flow rate-L/min	-	=
Back up heater capacity kW	6	=
<b>Visibility</b>		
Service Area (default)	<input type="checkbox"/>	=
Top Clearance (default)	200	=
Front Clearance (default)	800.0	=
Bottom Clearance (default)	30.0	=

## Family Types

Type name: HWT-1101F21ST6W-E

Search parameters

Parameter	Value	Formula
<b>Visibility</b>		
Service Area (default)	<input type="checkbox"/>	=
Top Clearance (default)	200	=
Front Clearance (default)	800.0	=
Bottom Clearance (default)	30.0	=
<b>Other</b>		
Operating range degC - Cooling	18 - 32	=
Operating range degC-Heating	5 - 32	=
Operating range degC-Hot water	5 - 32	=
Compressor detail (Type)	-	=
Compressor detail (Motor output W)	-	=
Refrigerant information	R32	=
Weight (Kg)	1Zone: 157kg 2Zone:162kg	=
<b>Identity Data</b>		
Article Description	ESTIA R32	=
Article Type	HWT-1101F21ST6W-E	=
Base Family Version		=
CB-NL Class		=
Content Supplier URL	www.hcltech.com	=
Copyright	©Toshiba / HCL	= "©Toshiba / HCL"
Custom	<input checked="" type="checkbox"/>	=
EMCS	4	= "4"
ETIM Article Class	EC001213	= "EC001213"
<b>Family Version</b>		
GLN		=
GTIN		=
Internal Art. No.		=
MEPcontent Class	HEATPUMP	= "HEATPUMP"
Manufacturer Art. No.	HWT-1101F21ST6W-E	=
Manufacturer URL	https://www.toshiba-carrier.co.jp/global/	=
Product Line	TCAE	= "TCAE"
Revit Version	2017	= "2017"
Stabu Code		=
Type Image		=
Keynote		=
Model	HWT-1101F21ST6W-E	=
Manufacturer	Toshiba	= "Toshiba"
<b>Type Comments</b>		
URL	https://www.toshiba-carrier.co.jp/global/	=
Description	ESTIA R32	=
Assembly Code		=
Cost		=
Watermarked By		=

# HWT-1101F21ST9W-E

## Family Types

Type name: HWT-1101F21ST9W-E

Search parameters

Parameter	Value	Formula
<b>Materials and Finishes</b>		
Red	Colour RGB-255 000 000	=
White	Colour RGB-255 255 255	=
<b>Electrical</b>		
MOCP	16	=
MCA	-	=
Running current-Cooling (A)	-	=
Power consumption-Cooling (Kw)	2.86	=
Running current-Heating (A)	-	=
Power consumption-Heating (kW)	2.39	=
Frequency (Hz)	50Hz	=
Voltage (V)	380-415V	=
Maximum current	13	=
<b>Dimensions</b>		
Height (mm)	1700.0	=
Width (mm)	600.0	=
Depth (mm)	670.0	=
Piping diameter Gas (mm)	15.9	=
Piping diameter Liquid (mm)	6.4	=
Water Piping diameter - Inlet/Outlet	Ø22 compression fitting	=
Drain piping diameter	-	=
<b>Mechanical - Flow</b>		
Static pressure Pa	-	=
Sound Power level (dB(A))	1zone 42dB(A) / 2zone 44dB(A)	=
<b>Mechanical - Loads</b>		
Rated Capacity kW - Cooling/Heating	8.0 / 11.0	=
Rated Power Consumption kW - Cooling/Heating	2.86/2.39	=
Rated efficiency-EER / COP	2.80 / 4.60	=
<b>Energy Analysis</b>		
Energy efficiency class - Low temp.	-	=
Seasonal space heating energy efficiency (ηs)	142%	=
Rated water flow rate-L/min	-	=
Back up heater capacity kW	9	=

## Family Types

Type name: HWT-1101F21ST9W-E

Search parameters

Parameter	Value	Formula
<b>Visibility</b>		
Service Area (default)	<input checked="" type="checkbox"/>	=
Top Clearance (default)	200	=
Front Clearance (default)	800.0	=
Bottom Clearance (default)	30.0	=
<b>Other</b>		
Operating range degC - Cooling	18 - 32	=
Operating range degC-Heating	5 - 32	=
Operating range degC-Hot water	5 - 32	=
Compressor detail (Type)	-	=
Compressor detail (Motor output W)	-	=
Refrigerant information	R32	=
Weight (Kg)	1Zone: 157kg 2Zone:162kg	=
<b>Identity Data</b>		
Article Description	ESTIA R32	=
Article Type	HWT-1101F21ST9W-E	=
Base Family Version		=
CB-NL Class		=
Content Supplier URL	www.hcltech.com	=
Copyright	©Toshiba / HCL	= "@Toshiba / HCL"
Custom	<input checked="" type="checkbox"/>	=
EMCS	4	= "4"
ETIM Article Class	EC001213	= "EC001213"
Family Version		=
GLN		=
GTIN		=
Internal Art. No.		=
MEPcontent Class	HEATPUMP	= "HEATPUMP"
Manufacturer Art. No.	HWT-1101F21ST9W-E	=
Manufacturer URL	https://www.toshiba-carrier.co.jp/global/	=
Product Line	TCAE	= "TCAE"
Revit Version	2017	= "2017"
Stabu Code		=
Type Image		=
Keynote		=
Model	HWT-1101F21ST9W-E	=
Manufacturer	Toshiba	= "Toshiba"
Type Comments		=
URL	https://www.toshiba-carrier.co.jp/global/	=
Description	ESTIA R32	=
Assembly Code		=
Cost		=
Watermarked By		=



**Thank You**