

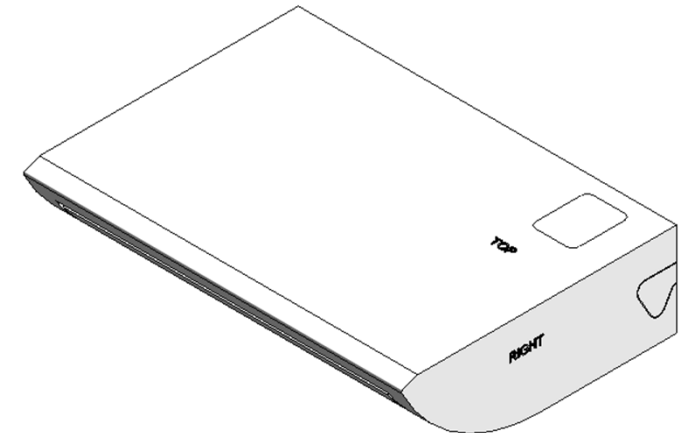

32- RAV_RM1CTP_40-56

11-02-2019

RAV_RM1CTP_40-56

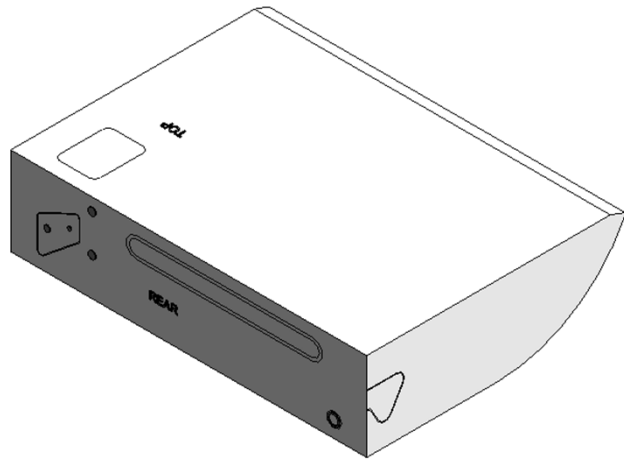
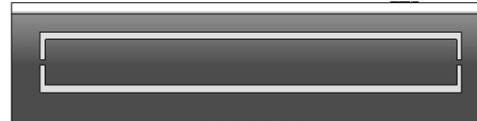
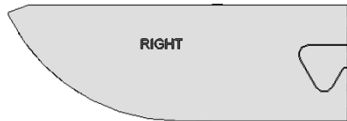

RAV_RM1CTP_40-56

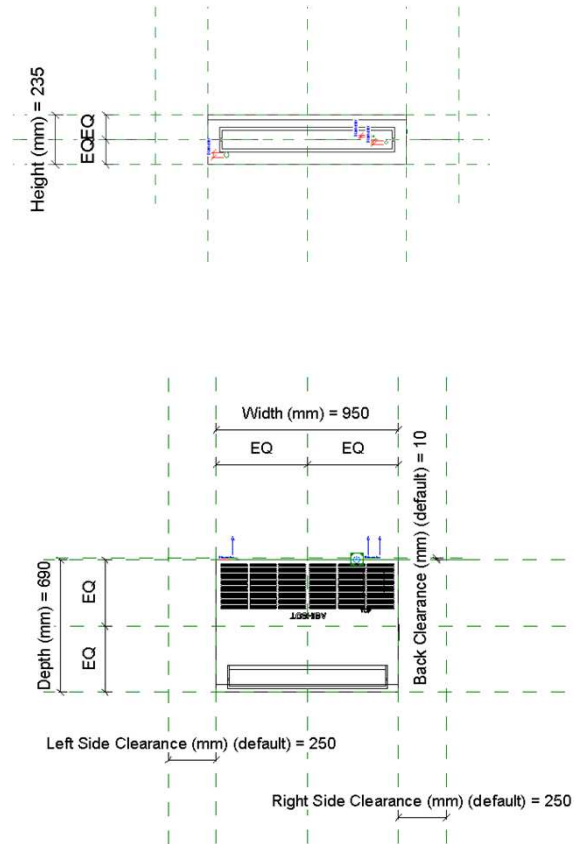

RAV_RM1CTP_40-56 Service Area

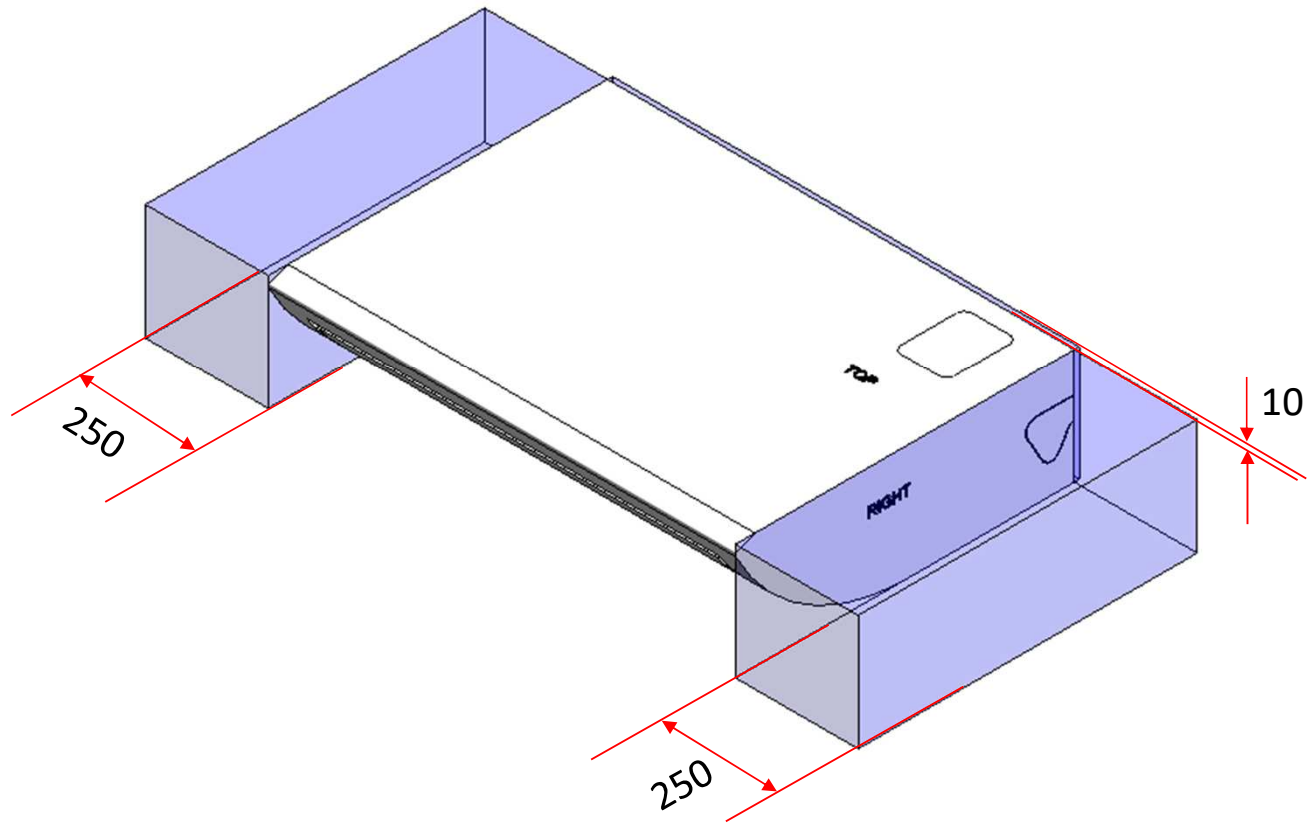

Electrical Connector

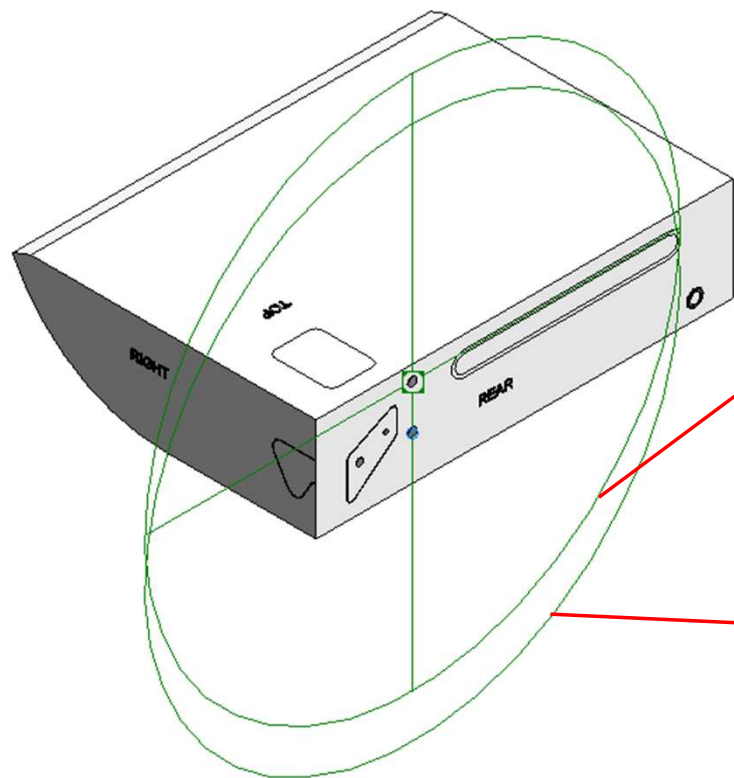

Properties	
R	
Connector Element (1) Edit Type	
Electrical - Loads	
System Type	Power - Unbalanced
Number of Poles	1
Power Factor State	Lagging
Load Classification	Other
Load Sub-Classification Motor	<input type="checkbox"/>
Voltage	0.00 V
Apparent Load Phase 1	0.00 VA
Apparent Load Phase 2	0.00 VA
Apparent Load Phase 3	0.00 VA
Power Factor	1.000000
Identity Data	
Utility	<input type="checkbox"/>
Connector Description	ELECTRICAL CONNECTION PORT

Properties	
R	
Connector Element (1) Edit Type	
Electrical - Loads	
System Type	Controls
Identity Data	
Utility	<input type="checkbox"/>
Connector Description	CONTROL CONNECTION PORT

Pipe Connectors

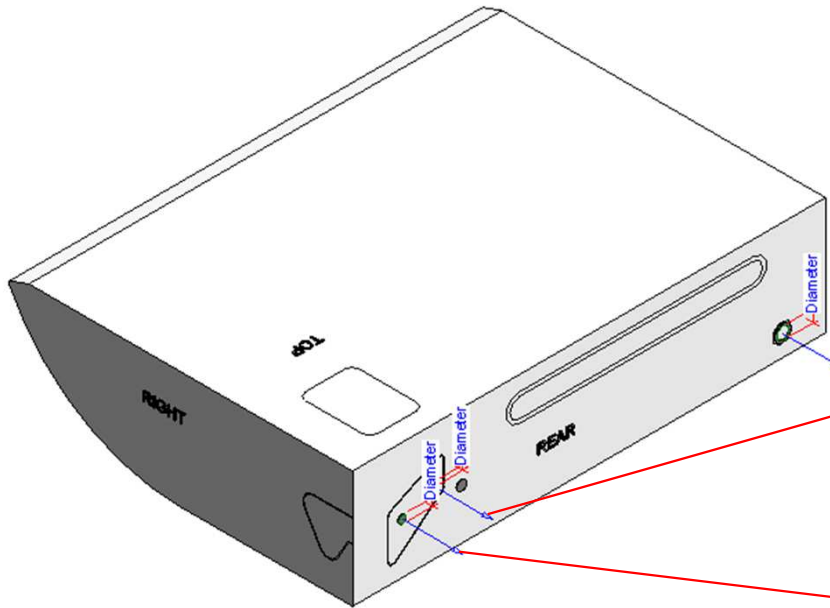

Properties

R

Connector Element (1) Edit Type

Dimensions	
Diameter	25.0
Mechanical	
K Coefficient	0.000000
Flow Factor	0.000000
Flow Configuration	Calculated
Flow Direction	Bidirectional
Loss Method	Not Defined
Allow Slope Adjustments	<input type="checkbox"/>
System Classification	Domestic Hot Water
Mechanical - Flow	
Fixture Units	0.000000
Flow	0.00 L/s
Pressure Drop	0.00 Pa
Identity Data	
Utility	<input type="checkbox"/>
Connector Description	

Properties

R

Connector Element (1) Edit Type

Dimensions	
Diameter	0.5
Mechanical	
K Coefficient	0.000000
Flow Factor	0.000000
Flow Configuration	Calculated
Flow Direction	Bidirectional
Loss Method	Not Defined
Allow Slope Adjustments	<input type="checkbox"/>
System Classification	Domestic Hot Water
Mechanical - Flow	
Fixture Units	0.000000
Flow	0.00 L/s
Pressure Drop	0.00 Pa
Identity Data	
Utility	<input type="checkbox"/>
Connector Description	

Properties

R

Connector Element (1) Edit Type

Dimensions	
Diameter	15.0
Mechanical	
K Coefficient	0.000000
Flow Factor	0.000000
Flow Configuration	Calculated
Flow Direction	Bidirectional
Loss Method	Not Defined
Allow Slope Adjustments	<input type="checkbox"/>
System Classification	Domestic Hot Water
Mechanical - Flow	
Fixture Units	0.000000
Flow	0.00 L/s
Pressure Drop	0.00 Pa
Identity Data	
Utility	<input type="checkbox"/>
Connector Description	

RAV-RM401CTP-E

Parameter	Value	Formula
Family Types		
Type name:	RAV-RM401CTP-E	
Search parameters		
Materials and Finishes		
Red	Colour- RGB-250 000 000	=
White	Colour- RGB 255 255 255	=
Electrical		
MOCP (A)	15	=
MCA (A)	-	=
Running current-Cooling (A)	4.10 - 3.75	=
Power consumption-Cooling (Kw)	0.83	=
Running current-Heating (A)	3.82 - 3.50	=
Power consumption-Heating (Kw)	0.78	=
Frequency (Hz)	50Hz	=
Voltage (V)	220-240V	=
Starting current (A)	9.15	=
Piping connection	Flare	=
Dimensions		
Height (mm)	235.0	=
Width (mm)	950.0	=
Depth (mm)	690.0	=
Hydronic Return Diameter (mm)	12.7	=
Hydronic Supply Diameter (mm)	6.4	=
Drain Pipe Diameter (mm)	26.0	=
Duct diameter (mm)	-	=
Weight (Kg)	23	=
Mechanical - Flow		
Static pressure (Pa)	-	=
Sound pressure - High (dB)	37	=
Sound pressure - Mid (dB)	35	=
Sound pressure - Low (dB)	28	=
Airflow (m3/h)	900	=
Air filter	Long life filter	=
Mechanical - Loads		
Rated Capacity-Cooling/Heating (kW)	3.6 / 4.0	=
Rated Power Consumption	0.83 / 0.78	=
Rated efficiency - EER / COP	4.34 / 5.13	=
Part load	-	=
Energy Analysis		
Energy Class-Cooling/Heating	A++ / A+++	=
Seasonal & Rated efficiency-EER/SCOP	6.34 / 5.10	=
Pdesign-Cooling/Heating	3.6 / 2.7	=

Visibility		
Service Area (default) (default)		=
Back Clearance (mm) (default)	10.0	=
Left Side Clearance (mm) (default)	250.0	=
Right Side Clearance (mm) (default)	250.0	=
Other		
Casing material	-	=
Operating range - Cooling (°C)	21 - 32	=
Operating range - Heating (°C)	0 - 28	=
Refrigerant Information	R410A / R32	=
Identity Data		
Article Description	R32 Ceiling	=
Article Type	RAV-RM401CTP-E	=
Base Family Version		=
CB-NL Class		=
Content Supplier URL	www.hcltech.com	=
Copyright	©Toshiba / HCL	"©Toshiba / HCL"
EMCS	4	"4"
ETIM Article Class	EC001213	"EC001213"
Family Version		=
GLN		=
GTIN		=
Internal Art. No.		=
MEPcontent Class	HEATPUMP	"HEATPUMP"
Manufacturer	Toshiba	"Toshiba"
Manufacturer Art. No.	RAV-RM401CTP-E	=
Manufacturer URL	https://www.toshiba-carrier.co.jp/global/	=
Product Line	TCTC	"TCTC"
Revit Version	2017	"2017"
Stabu Code		=
Type Image		=
Keynote		=
Model	RAV-RM401CTP-E	=
Type Comments		=
URL	https://www.toshiba-carrier.co.jp/global/	=
Description	R32 Ceiling	=
Assembly Code		=
Cost		=
Watermarked By		=
Wholesaler		=
Wholesaler Art. No.		=

RAV-RM561CTP-E

Family Types		
Type name:	RAV-RM561CTP-E	
Search parameters		
Parameter	Value	Formula
Materials and Finishes		
Red	Colour- RGB-250 000 000	=
White	Colour- RGB 255 255 255	=
Electrical		
MOCP (A)	15	=
MCA (A)	-	=
Running current-Cooling (A)	6.70 - 6.14	=
Power consumption-Cooling (Kw)	1.37	=
Running current-Heating (A)	6.71 - 6.15	=
Power consumption-Heating (Kw)	1.39	=
Frequency (Hz)	50	=
Voltage (V)	220-240	=
Starting current (A)	13.1	=
Piping connection	Flare	=
Dimensions		
Height (mm)	235.0	=
Width (mm)	950.0	=
Depth (mm)	690.0	=
Hydronic Return Diameter (mm)	12.7	=
Hydronic Supply Diameter (mm)	6.4	=
Drain Pipe Diameter (mm)	26.0	=
Duct diameter (mm)	-	=
Weight (Kg)	23	=
Mechanical - Flow		
Static pressure (Pa)	-	=
Sound pressure - High (dB)	37	=
Sound pressure - Mid (dB)	35	=
Sound pressure - Low (dB)	28	=
Airflow (m3/h)	900	=
Air filter	Long life filter	=
Mechanical - Loads		
Rated Capacity-Cooling/Heating (kW)	5.0 / 5.6	=
Rated Power Consumption	1.37 / 1.39	=
Rated efficiency - EER / COP	3.65 / 4.03	=
Part load	-	=
Energy Analysis		
Energy Class-Cooling/Heating	A++ / A++	=
Seasonal & Rated efficiency-EER/SCOP	6.76 / 4.70	=
Pdesign-Cooling/Heating	5.0 / 3.8	=

Visibility		
Service Area (default) (default)	<input type="checkbox"/>	=
Back Clearance (mm) (default)	10.0	=
Left Side Clearance (mm) (default)	250.0	=
Right Side Clearance (mm) (default)	250.0	=
Other		
Casing material	-	=
Operating range - Cooling (°C)	21 - 32	=
Operating range - Heating (°C)	0 - 28	=
Refrigerant Information	R32	=
Identity Data		
Article Description	R32 Ceiling	=
Article Type	RAV-RM561CTP-E	=
Base Family Version		=
CB-NL Class		=
Content Supplier URL	www.hcltech.com	=
Copyright	©Toshiba / HCL	= "©Toshiba / HCL"
EMCS	4	= "4"
ETIM Article Class	EC001213	= "EC001213"
Family Version		=
GLN		=
GTIN		=
Internal Art. No.		=
MEPcontent Class	HEATPUMP	= "HEATPUMP"
Manufacturer	Toshiba	= "Toshiba"
Manufacturer Art. No.	RAV-RM561CTP-E	=
Manufacturer URL	https://www.toshiba-carrier.co.jp/global/	=
Product Line	TCTC	= "TCTC"
Revit Version	2017	= "2017"
Stabu Code		=
Type Image		=
Keynote		=
Model	RAV-RM561CTP-E	=
Type Comments		=
URL	https://www.toshiba-carrier.co.jp/global/	=
Description	R32 Ceiling	=
Assembly Code		=
Cost		=
Watermarked By		=
Wholesaler		=
Wholesaler Art. No.		=



Thank You