

34- RAV_RM1CTP_110-140

11-02-2019

RAV_RM1CTP_110-140

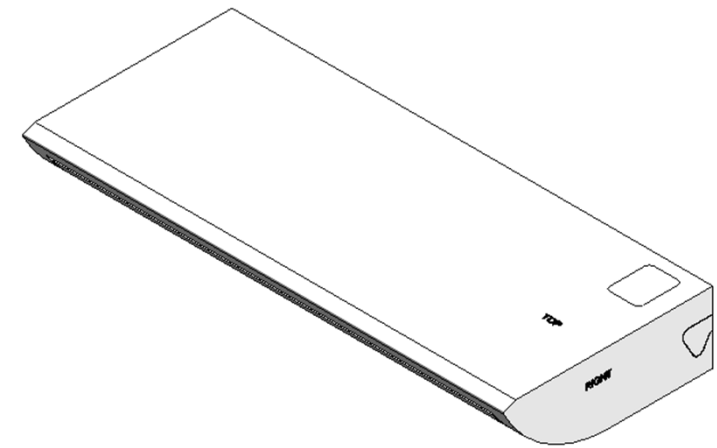
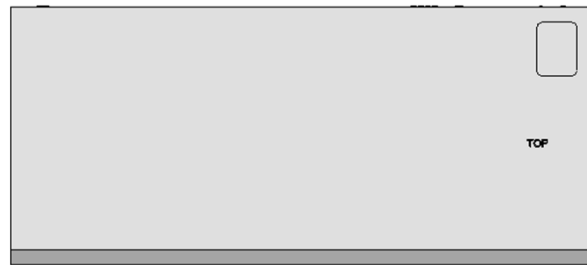
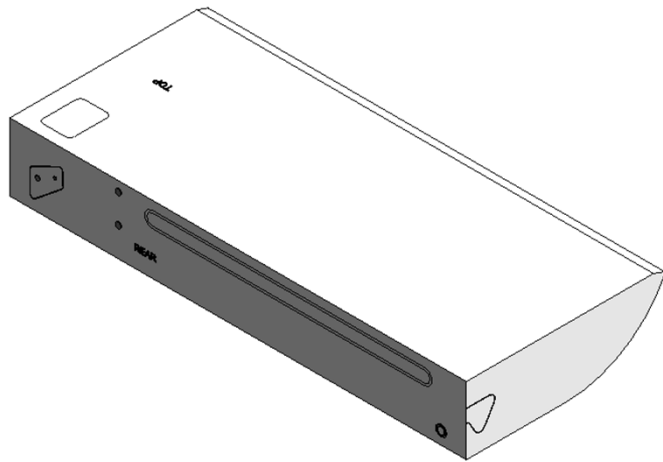

RAV_RM1CTP_110-140

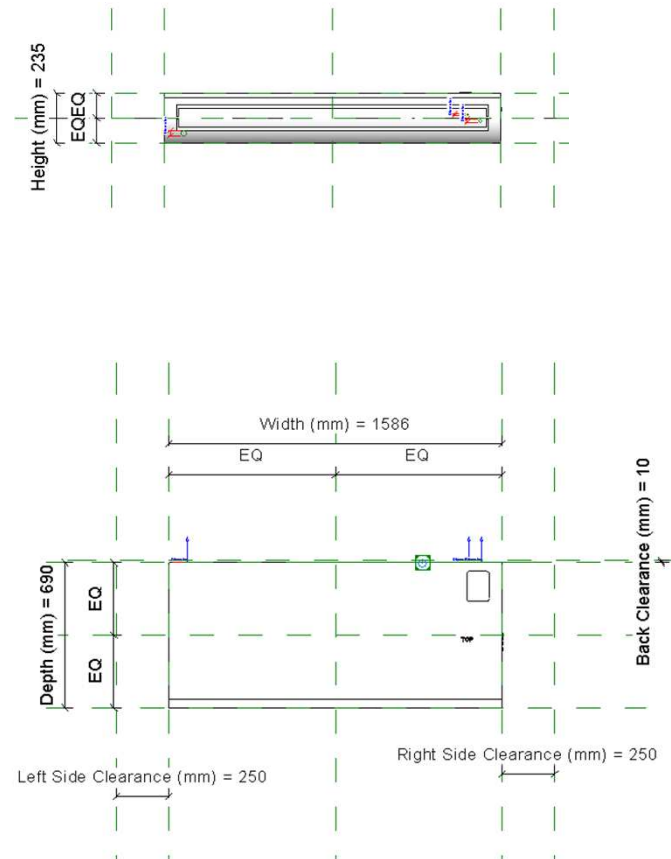

RAV_RM1CTP_110-140 Service Area

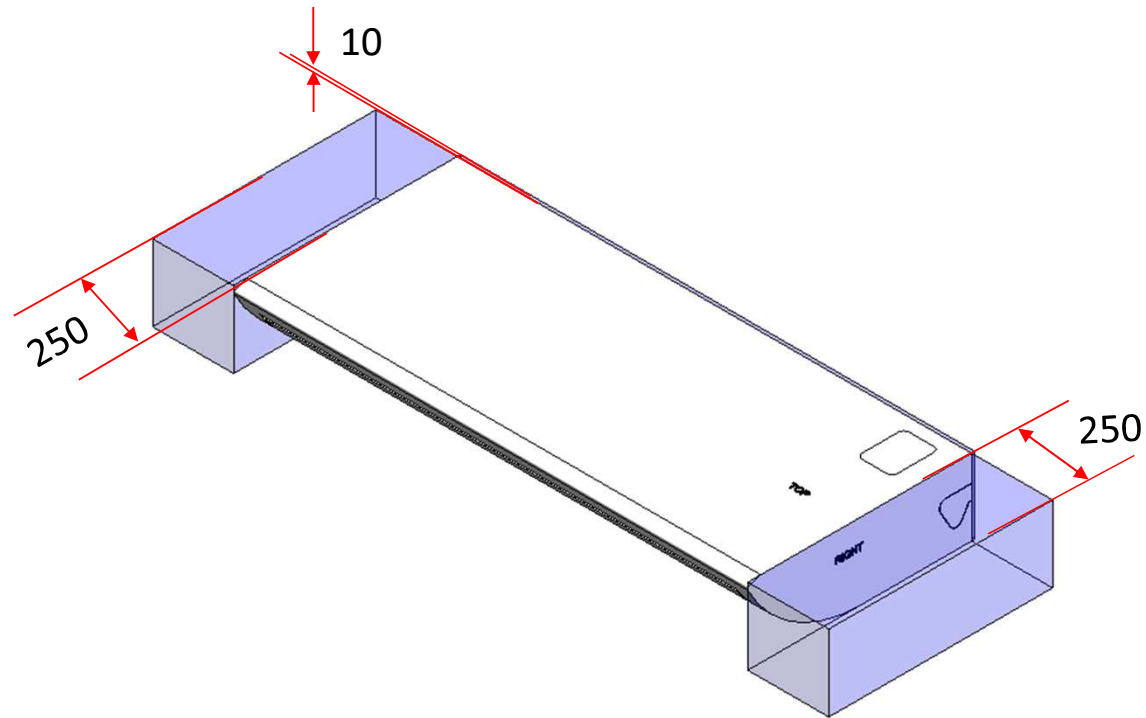

Electrical Connector

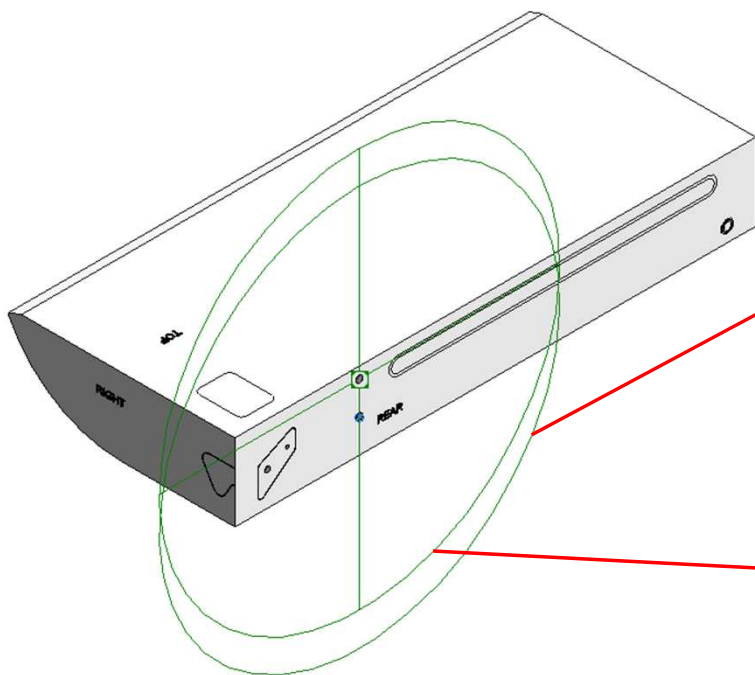

Properties	
R	
Connector Element (1) Edit Type	
Electrical - Loads	
System Type	Controls
Identity Data	
Utility	<input type="checkbox"/>
Connector Description	CONTROL CONNECTION PORT

Properties	
R	
Connector Element (1) Edit Type	
Electrical - Loads	
System Type	Power - Unbalanced
Number of Poles	1
Power Factor State	Lagging
Load Classification	Other
Load Sub-Classification Motor	<input type="checkbox"/>
Voltage	0.00 V
Apparent Load Phase 1	0.00 VA
Apparent Load Phase 2	0.00 VA
Apparent Load Phase 3	0.00 VA
Power Factor	1.000000
Identity Data	
Utility	<input type="checkbox"/>
Connector Description	ELECTRICAL CONNECTION PORT

Pipe Connectors

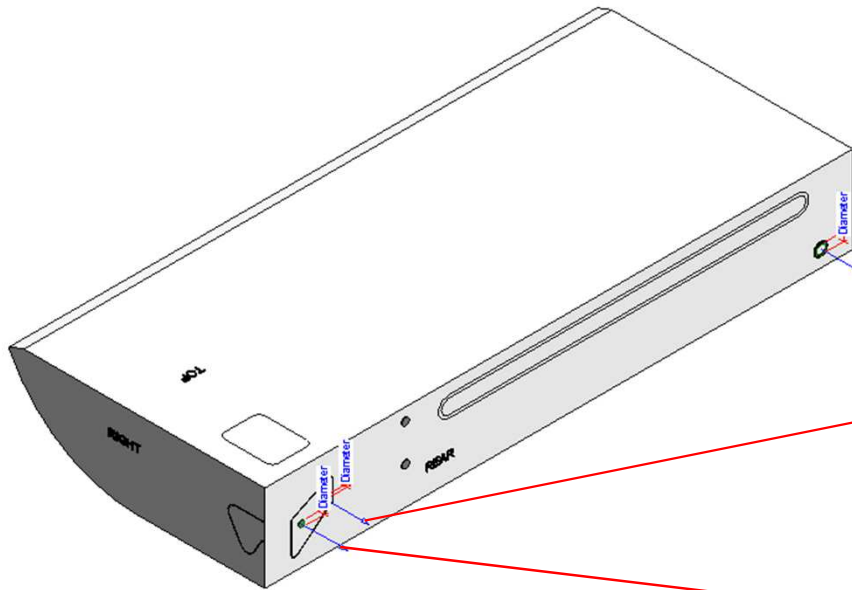

Properties	
R	
Connector Element (1)	✕ Edit Type
Dimensions	
Diameter	53.0
Mechanical	
K Coefficient	0.000000
Flow Factor	0.000000
Flow Configuration	Calculated
Flow Direction	Bidirectional
Loss Method	Not Defined
Allow Slope Adjustments	<input type="checkbox"/>
System Classification	Domestic Hot Water
Mechanical - Flow	
Fixture Units	0.000000
Flow	0.00 L/s
Pressure Drop	0.00 Pa
Identify Data	
Utility	<input type="checkbox"/>
Connector Description	

Properties	
R	
Connector Element (1)	✕ Edit Type
Dimensions	
Diameter	9.5
Mechanical	
K Coefficient	0.000000
Flow Factor	0.000000
Flow Configuration	Calculated
Flow Direction	Bidirectional
Loss Method	Not Defined
Allow Slope Adjustments	<input type="checkbox"/>
System Classification	Domestic Hot Water
Mechanical - Flow	
Fixture Units	0.000000
Flow	0.00 L/s
Pressure Drop	0.00 Pa
Identify Data	
Utility	<input type="checkbox"/>
Connector Description	

Properties	
R	
Connector Element (1)	✕ Edit Type
Dimensions	
Diameter	15.9
Mechanical	
K Coefficient	0.000000
Flow Factor	0.000000
Flow Configuration	Calculated
Flow Direction	Bidirectional
Loss Method	Not Defined
Allow Slope Adjustments	<input type="checkbox"/>
System Classification	Domestic Hot Water
Mechanical - Flow	
Fixture Units	0.000000
Flow	0.00 L/s
Pressure Drop	0.00 Pa
Identify Data	
Utility	<input type="checkbox"/>
Connector Description	

RAV-RM1101CTP-E

Family Types		
Type name:	RAV-RM1101CTP-E	
Search parameters		
Parameter	Value	Formula
Materials and Finishes		
Red	Colour RGB-250 000 000	=
White	Colour- RGB 255 255 255	=
Electrical		
MOCp (A)	25	=
MCA (A)	-	=
Running current-Cooling (A)	10.67 - 9.78	=
Power consumption-Cooling (Kw)	2.23	=
Running current-Heating (A)	11.39 - 10.44	=
Power consumption-Heating (Kw)	2.38	=
Frequency (Hz)	50Hz	=
Voltage (V)	220-240V	=
Starting current (A)	21	=
Piping connection	Flare	=
Dimensions		
Height (mm)	235.0	=
Width (mm)	1586.0	=
Depth (mm)	690.0	=
Hydronic Return Diameter (mm)	15.9	=
Hydronic Supply Diameter (mm)	9.5	=
Drain Pipe Diameter (mm)	26.0	=
Duct Diameter (mm)	-	=
Weight (Kg)	37	=
Mechanical - Flow		
Static pressure (Pa)	-	=
Sound pressure - High (dB)	44	=
Sound pressure - Mid (dB)	38	=
Sound pressure - Low (dB)	32	=
Airflow (m3/h)	1860	=
Air filter	Long life filter	=
Mechanical - Loads		
Rated Capacity -Cooling/Heating (kW)	9.5 / 11.2	=
Rated Power Consumption	2.95 / 2.94	=
Rated efficiency - EER / COP	3.22 / 3.81	=
Part load	-	=
Energy Analysis		
Energy Class- Cooling/Heating	A+ / A+	=
Seasonal & Rated efficiency-SEER / SCOP	5.86 / 4.27	=
Pdesign-Cooling/Heating	9.5 / 7.6	=

Visibility		
Service Area (default)	<input type="checkbox"/>	=
Back Clearance (mm) (default)	10.0	=
Right Side Clearance (mm) (default)	250.0	=
Left Side Clearance (mm) (default)	250.0	=
Other		
Casing material	-	=
Operating range - Cooling (°C)	21 - 32	=
Operating range - Heating (°C)	0 - 28	=
Refrigerant Information	R32 / R410A	=
Identity Data		
Article Description	R32 Ceiling	=
Article Type	RAV-RM1101CTP-E	=
Base Family Version		=
CB-NL Class		=
Content Supplier URL	www.hcltech.com	=
Copyright	©Toshiba / HCL	= "©Toshiba / HCL"
EMCS	4	= "4"
ETIM Article Class	EC001213	= "EC001213"
Family Version		=
GLN		=
GTIN		=
Internal Art. No.		=
MEPcontent Class	HEATPUMP	= "HEATPUMP"
Manufacturer	Toshiba	= "Toshiba"
Manufacturer Art. No.	RAV-RM1101CTP-E	=
Manufacturer URL	https://www.toshiba-carrier.co.jp/global/	=
Product Line	TCTC	= "TCTC"
Revit Version	2017	= "2017"
Stabu Code		=
Type Image		=
Keynote		=
Model	RAV-RM1101CTP-E	=
Type Comments		=
URL	https://www.toshiba-carrier.co.jp/global/	=
Description	R32 Ceiling	=
Assembly Code		=
Cost		=
Watermarked By		=
Wholesaler		=
Wholesaler Art. No.		=

RAV-RM1401CTP-E

Family Types		
Type name:	RAV-RM1401CTP-E	
Search parameters		
Parameter	Value	Formula
Materials and Finishes		
Red	Colour RGB-250 000 000	=
White	Colour- RGB 255 255 255	=
Electrical		
MOCP (A)	25	=
MCA (A)	-	=
Running current-Cooling (A)	17.13 - 15.70	=
Power consumption-Cooling (Kw)	3.58	=
Running current-Heating (A)	17.18 - 15.75	=
Power consumption-Heating (Kw)	3.59	=
Frequency (Hz)	50	=
Voltage (V)	220-240	=
Starting current (A)	21.6	=
Piping cconnection	Flare	=
Dimensions		
Height (mm)	235.0	=
Width (mm)	1586.0	=
Depth (mm)	690.0	=
Hydronic Return Diameter (mm)	15.9	=
Hydronic Supply Diameter (mm)	9.5	=
Drain Pipe Diameter (mm)	26.0	=
Duct Diameter (mm)	-	=
Weight (Kg)	37	=
Mechanical - Flow		
Static pressure (Pa)	-	=
Sound pressure - High (dB)	46	=
Sound pressure - Mid (dB)	41	=
Sound pressure - Low (dB)	35	=
Airflow (m3/h)	2040	=
Air filter	Long life filter	=
Mechanical - Loads		
Rated Capacity -Cooling/Heating (kW)	12.5 / 14.0	=
Rated Power Consumption	3.58 / 3.59	=
Rated efficiency - EER / COP	3.49 / 3.90	=
Part load	-	=
Energy Analysis		
Energy Class- Cooling/Heating	-	=
Seasonal & Rated efficiency-SEER / SCOP	-	=
Pdesign-Cooling/Heating	-	=

Visibility		
Service Area (default)	<input type="checkbox"/>	=
Back Clearance (mm) (default)	10.0	=
Right Side Clearance (mm) (default)	250.0	=
Left Side Clearance (mm) (default)	250.0	=
Other		
Casing material	-	=
Operating range - Cooling (°C)	21 - 32	=
Operating range - Heating (°C)	0 - 28	=
Refrigerant Information	R32 / R410A	=
Identity Data		
Article Description	R32 Ceiling	=
Article Type	RAV-RM1401CTP-E	=
Base Family Version		=
CB-NL Class		=
Content Supplier URL	www.hcltech.com	=
Copyright	© Toshiba / HCL	= "©Toshiba / HCL"
EMCS	4	= "4"
ETIM Article Class	EC001213	= "EC001213"
Family Version		=
GLN		=
GTIN		=
Internal Art. No.		=
MEPcontent Class	HEATPUMP	= "HEATPUMP"
Manufacturer	Toshiba	= "Toshiba"
Manufacturer Art. No.	RAV-RM1401CTP-E	=
Manufacturer URL	https://www.toshiba-carrier.co.jp/global/	=
Product Line	TCTC	= "TCTC"
Revit Version	2017	= "2017"
Stabu Code		=
Type Image		=
Keynote		=
Model	RAV-RM1401CTP-E	=
Type Comments		=
URL	https://www.toshiba-carrier.co.jp/global/	=
Description	R32 Ceiling	=
Assembly Code		=
Cost		=
Watermarked By		=
Wholesaler		=
Wholesaler Art. No.		=

RAV-RM1601CTP-E

Family Types		
Type name:	RAV-RM1601CTP-E	
Search parameters		
Parameter	Value	Formula
Materials and Finishes		
Red	Colour RGB-250 000 000	=
White	Colour- RGB 255 255 255	=
Electrical		
MOCP (A)	25	=
MCA (A)	-	=
Running current-Cooling (A)	7.60 - 6.96	=
Power consumption-Cooling (Kw)	4.50	=
Running current-Heating (A)	7.28 - 6.66	=
Power consumption-Heating (Kw)	4.31	=
Frequency (Hz)	3Phase , 50	=
Voltage (V)	380-415	=
Starting current (A)	16.1	=
Piping cnnction	Flare	=
Dimensions		
Height (mm)	235.0	=
Width (mm)	1586.0	=
Depth (mm)	690.0	=
Hydronic Return Diameter (mm)	15.9	=
Hydronic Supply Diameter (mm)	9.5	=
Drain Pipe Diameter (mm)	26.0	=
Duct Diameter (mm)	-	=
Weight (Kg)	37	=
Mechanical - Flow		
Static pressure (Pa)	-	=
Sound pressure - High (dB)	46	=
Sound pressure - Mid (dB)	42	=
Sound pressure - Low (dB)	36	=
Airflow (m3/h)	2040	=
Air filter	Long life filter	=
Mechanical - Loads		
Rated Capacity - Cooling/Heating (kW)	14.0 / 16.0	=
Rated Power Consumption	4.50 / 4.31	=
Rated efficiency - EER / COP	3.11 / 3.71	=
Part load	-	=
Energy Analysis		
Energy Class- Cooling/Heating	-	=
Seasonal & Rated efficiency-SEER / SCOP	-	=
Pdesign-Cooling/Heating	-	=

Visibility		
Service Area (default)	<input type="checkbox"/>	=
Back Clearance (mm) (default)	10.0	=
Right Side Clearance (mm) (default)	250.0	=
Left Side Clearance (mm) (default)	250.0	=
Other		
Casing material	-	=
Operating range - Cooling (°C)	21 - 32	=
Operating range - Heating (°C)	0 - 28	=
Refrigerant Information	R410A	=
Identity Data		
Article Description	R410A Ceiling	=
Article Type	RAV-RM1601CTP-E	=
Base Family Version		=
CB-NL Class		=
Content Supplier URL	www.hcltech.com	=
Copyright	©Toshiba / HCL	"©Toshiba / HCL"
EMCS	4	"4"
ETIM Article Class	EC001213	"EC001213"
Family Version		
GLN		=
GTIN		=
Internal Art. No.		=
MEPcontent Class	HEATPUMP	"HEATPUMP"
Manufacturer	Toshiba	"Toshiba"
Manufacturer Art. No.	RAV-RM1601CTP-E	=
Manufacturer URL	https://www.toshiba-carrier.co.jp/global/	=
Product Line	TCTC	"TCTC"
Revit Version	2017	"2017"
Stabu Code		=
Type Image		=
Keynote		=
Model	RAV-RM1601CTP-E	=
Type Comments		=
URL	https://www.toshiba-carrier.co.jp/global/	=
Description	R410A Ceiling	=
Assembly Code		=
Cost		=
Watermarked By		=
Wholesaler		=
Wholesaler Art. No.		=



Thank You