

# ARTU

## BASES DE TOMA SERIE ARTU OUTLETS ARTU SERIES PRISES D'ARRIVÉE SÉRIE ARTU

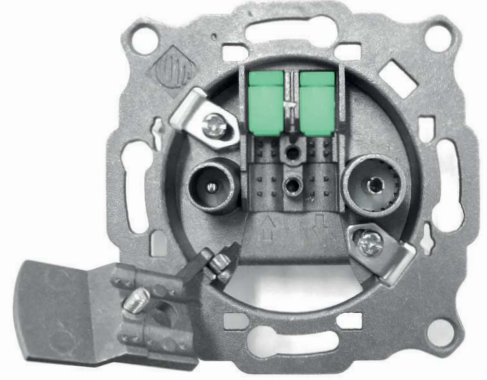

- Bases de toma filtradas para montaje individual y en cascada.
- Amarre rápido del cable gracias a la brida basculante.
- Conexión fácil a través del sistema para inserción del vivo.
- Mínimas pérdidas de paso.
- Paso de corriente por el conector C2, salida SAT.
- Compatible con las principales placas embellecedoras del mercado.

- Filtered outlet sockets for individual or cascade assembly.
- Fast clamping of the cable thanks to the swivel flange.
- Easy connection using the system to insert live product.
- Minimum current losses.
- Current flow through the C2 connector, SAT output.
- Compatible with the main wall-covering plates on the market.

- Prises d'arrivée filtrées pour montage individuel et en cascade.
- Fixation rapide du câble grâce à la bride basculante.
- Connexion simplifiée par le système d'insertion du câble phase.
- Pertes de passage réduites au minimum.
- Passage de courant dans le connecteur C2, sortie SAT.
- Compatible avec les principales plaques de finition du marché.

**Instalaciones MATV**  
**MATV installations**  
**Installations MATV**

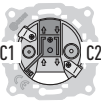
Modelo Model Modèle		ARTU008		ARTU081
Ref.		2574		2576
Instalación Installation Installation		Final End Finale		
Tipo Type Type		Puenteada Bridget Ponté	Resistiva Resistive Résistance	
Conector Connector Connecteur		C1	IEC macho IEC male IEC mâle	
		C2	IEC hembra IEC female IEC femelle	
Rango de frecuencias Frequency range Bande passante	MHz	C1	5 - 862	5 - 1000
		C2		
Atenuación de conexión Transfer loss Atténuation de connexion	dB	TV	< 1,5	< 3
		RD	< 1,5	< 10
Desacople C1-C2 C1-C2 Isolation Découplage C1-C2	dB	TV	-	< 15
		RD	-	> 10
Pérdidas de retorno Return losses Pertes de retour	dB	TV	-	> 10
		RD	-	> 10
Garras de fijación Fixing hooks Griffes de fixation			Sí Yes Oui	
Unidades / Embalaje Units / Packaging Unités / Emballage			10 / 100	
Peso embalado Packed weight Poids emballé	kg	0,872 / 9,5		
Dimensiones embalaje Packing dimensions Dimensions d'emballage	mm	170x70x130 / 780x160x180		

**Ejemplos de instalación**  
**Installation examples**  
**Exemples d'installation**

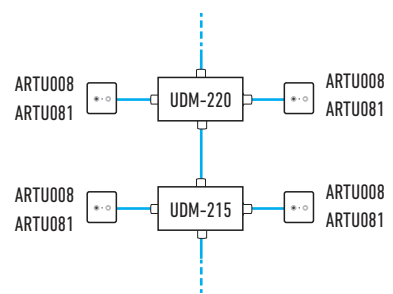
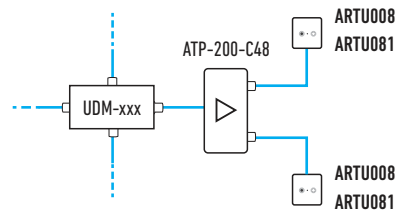
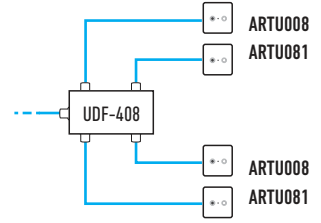

Modelo Model Modèle		ARTU088	ARTU068
Ref.		2570	2571
Instalación Installation Installation		Individual Single Individuel	
Tipo Type Type		Filtrada Filtered Filtré	
Conector Connector Connecteur		C1	IEC macho IEC male IEC mâle
		C2	IEC hembra IEC female IEC femelle
Rango de frecuencias Frequency range Bande passante	MHz	C1	5 - 862      5 - 694
		C2	950 - 2400
Atenuación de conexión Transfer loss Atténuation de connexion	dB	TV	< 1
		SAT	< 1,5
Desacoplo C1-C2 C1-C2 Isolation Découplage C1-C2	dB	TV	> 25
		SAT	> 25
Selectividad Selectivity Sélectivité	dB	TV	> 15
		SAT	> 20
Pérdidas de retorno Return losses Pertes de retour	dB	TV	> 10
		SAT	> 6
Paso de corriente C2 DC transit C2 Passage de courant C2	VDC	24	
	mA	500	
	Tono/Tone/Ton	22 kHz / DiSEqC	
Garras de fijación Fixing hooks Griffes de fixation	Sí	Yes	No
	Yes	Yes	No
	Oui	Oui	Non
Unidades / Embalaje Units / Packaging Unités / Emballage		10 / 100	
Peso embalado Packed weight Poids emballé	kg	0,872 / 9,5	
Dimensiones embalaje Packing dimensions Dimensions d'emballage		170x70x130 / 780x160x180	

Ejemplos de instalación  
 Installation examples  
 Exemples d'installation

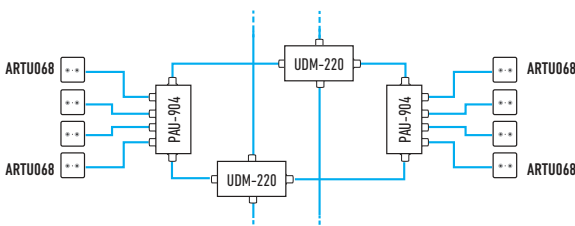
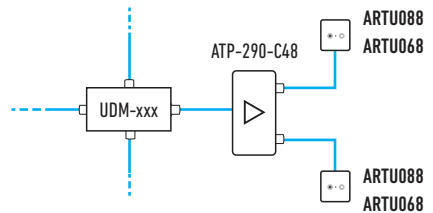
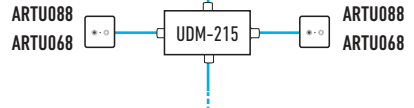
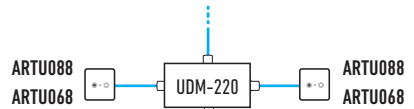
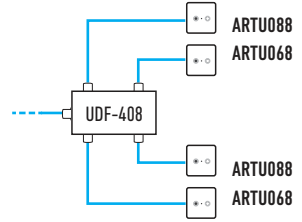

**Instalaciones SMATV**  
**SMATV installations**  
**Installations SMATV**

Modelo Model Modèle		ARTU980	ARTU981	ARTU982	ARTU983	
REF.		2578	2579	2580	2575	
Instalación Installation Installation		Final End Finale	Intermedia Intermediate intermédiaire	Intermedia Intermediate intermédiaire	Intermedia Intermediate intermédiaire	
Tipo Type Type		Inductiva Inductive Inductive				
Conector Connector Connecteur		C1	IEC macho IEC male IEC mâle			
		C2	IEC hembra IEC female IEC femelle			
Rango de frecuencias Frequency range Bande passante	MHz	C1	5 - 862 / 950 - 2400			
Atenuación de conexión Transfer loss Atténuation de connexion	dB	TV+RD	< 4,5 en C1 < 6 en C2	< 9	< 13	< 20
		SAT		< 10	< 14	< 24
Atenuación de paso Through loss Atténuation de passage	dB	TV+RD	-	< 2	< 1,2	< 0,5
		SAT	-	< 3	< 2	< 1,2
Desacoplo C1-C2 C1-C2 Isolation Découplage C1-C2	dB	TV+RD	> 16	> 25	> 25	> 25
		SAT				
Selectividad Selectivity Sélectivité	dB	TV+RD	-			
		SAT				
Pérdidas de retorno Return losses Pertes de retour	dB	TV+RD	> 10			
		SAT	> 6			
Paso de corriente C2 DC transit C2 Passage de courant C2	VDC	24				
	mA	500				
	Tono/Tone/Ton	22 kHz / DiSEqC				
Garras de fijación Fixing hooks Griffes de fixation			Sí Yes Oui			
Unidades / Embalaje Units / Packaging Unités / Emballage			10 / 100			
Peso embalado Packed weight Poids emballé	kg	0,872 / 9,5				
Dimensiones embalaje Packing dimensions Dimensions d'emballage	mm	170x70x130 / 780x160x180				

Ejemplos de instalación  
 Installation examples  
 Exemples d'installation

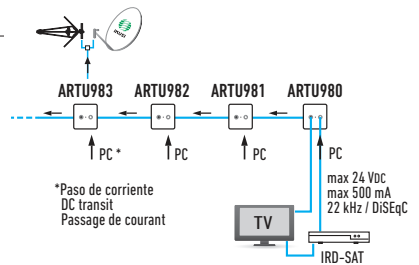
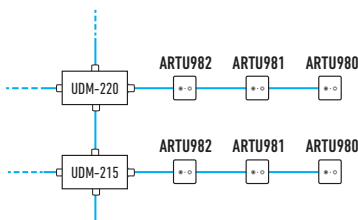
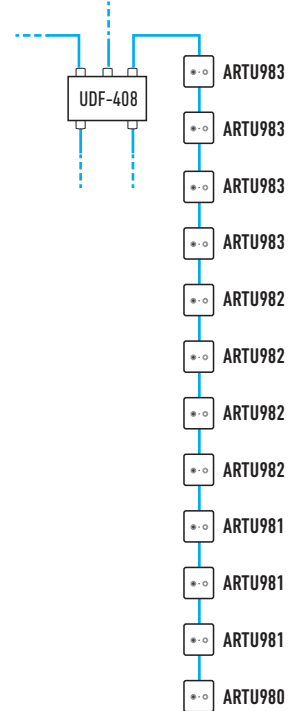

\*Paso de corriente  
 DC transit  
 Passage de courant

**Instalaciones CATV**  
**CATV installations**  
**Installations CATV**

Modelo Model Modèle		ARTU111	
REF.		2573	
Instalación Installation Installation		Individual Single Individuel	
Tipo Type Type		Filtrada Filtered Filtré	
Conector Connector Connecteur		C1	IEC macho IEC male IEC mâle
		C2	IEC hembra IEC female IEC femelle
Rango de frecuencias Frequency range Bande passante	MHz	C1	5 - 68 / 118 - 1000
		C2	88 - 108
Atenuación de conexión Transfer loss Atténuation de connexion	dB	TV	< 0,5
		RD	< 3
Desacoplo C1-C2 C1-C2 Isolation Découplage C1-C2	dB	TV	> 10
		RD	
Selectividad Selectivity Sélectivité	dB	TV	> 15
		RD	
Pérdidas de retorno Return losses Pertes de retour	dB	TV	> 13
		RD	> 15
Garras de fijación Fixing hooks Griffes de fixation		Sí Yes Oui	
Unidades / Embalaje Units / Packaging Unités / Emballag		10 / 100	
Peso embalado Packed weight Poids emballé	kg	0,872 / 9,5	
Dimensiones embalaje Packing dimensions Dimensions d'emballage	mm	170x70x130 / 780x160x180	

**Ejemplos de instalación**  
**Installation examples**  
**Exemples d'installation**

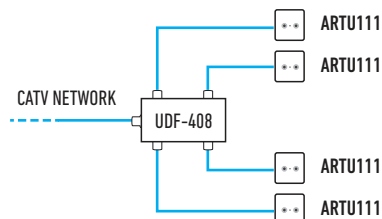

**Placas embellecedoras**  
**Coverplates**  
**Plastrons**

Modelo Model Modèle		PBT-980	PBT-990	PBT-480
REF.		2488	2489	2490
Descripción Description		TV+SAT - TV+SAT	TV+RD - SAT	TV - RD
Para la Base de toma For Outlet Pour la Prise d'arrivée	Ref.	2578 ; 2579 ; 2580 ; 2575	2570 ; 2571	2574 ; 2576 ; 2573
Unidades / Embalaje Units / Packaging Unités / Emballage		10		
Peso embalado Packed weight Poids emballé		g 172		
Dimensiones embalaje Packing dimensions Dimensions d'emballage		mm 104 x 85 x 80		



**Accesorios**  
**Accessories**  
**Accessoires**

Modelo Model Modèle		ABT-210	
REF.		1460	
Descripción Description Description		Zócalo para montaje en superficie, adaptable a cualquier base de toma Mounting of the outlets without embedding the body in the wall Socle pour montage de prises en saillie	
Unidades / Embalaje Units / Packaging Unités / Emballage		1 / 50	
Peso embalado Packed weight Poids emballé		kg	0,245 / 1,445
Dimensiones embalaje Packing dimensions Dimensions d'emballage		mm	80 x 80 x 25 / 360 x 290 x 30



**Garras de fijación**  
Fixing hooks  
Griffes fixation

**Terminales de conexión**  
Terminals connection  
Bornes de conection

**C1**  
Conector macho  
Male connector  
Connecteur mâle

**C2**  
Conector hembra  
Female connector  
Connecteur femmelle

**Brida basculante de amarre**  
Mooring swing clamp  
Bride d'amarriage

**Preparación del cable**  
Preparing the cable  
Préparation du câble

**Vista posterior**  
Rear view  
Vue arrière

**Conexión del cable en la base de toma ARTU**  
**Connecting the cable to the ARTU outlet**  
**Connexion du câble à la prise d'arrivée ARTU**

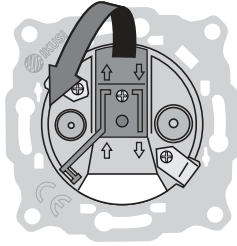

**Abrir la brida de amarre**  
**Open the mooring clamp**  
**Ouvrez la pince d'amarrage**

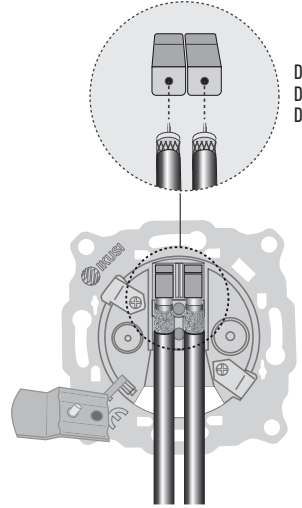
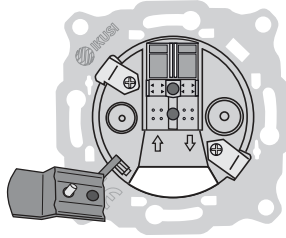

**Detalle**  
**Detail**  
**Détail**

**Introducir el conductor interno del cable**  
**Insert the internal conductor of the cable**  
**Insérez le conducteur interne du câble**

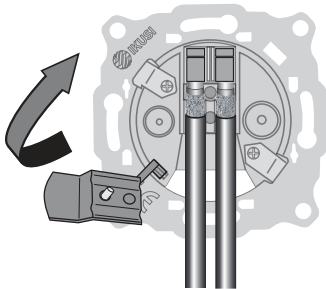

**Cerrar la brida de amarre**  
**Close the clamp**  
**Fermer la pince d'amarrage**

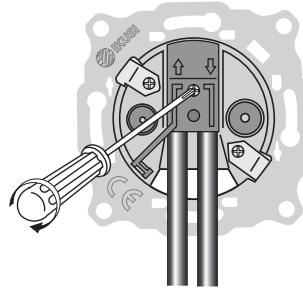

**Apretar el tornillo**  
**Tightening the screw**  
**Serrer la vis**

# PSE-300

## BASE DE TOMA PARA TV y RADIO OUTLET FOR TV and RADIO PRISE D'ARRIVÉE POUR TV et RADIO



### Instalaciones SMATV SMATV installations Installations SMATV

Modelo Model Modèle	PSE-300							
REF.	5360							
Tipo Type Type	Final End Finale							
Conector Connector Connecteur		<table border="1"> <tr> <td>C1</td> <td>IEC macho IEC male IEC mâle</td> </tr> <tr> <td>C2</td> <td>IEC hembra IEC female IEC femelle</td> </tr> <tr> <td>C3</td> <td>F</td> </tr> </table>	C1	IEC macho IEC male IEC mâle	C2	IEC hembra IEC female IEC femelle	C3	F
C1	IEC macho IEC male IEC mâle							
C2	IEC hembra IEC female IEC femelle							
C3	F							
Rango de frecuencias Frequency range Bande passante	MHz	<table border="1"> <tr> <td>C1</td> <td>5 - 68 y/and/et 125 - 862</td> </tr> <tr> <td>C2</td> <td>88 - 108</td> </tr> <tr> <td>C3</td> <td>950 - 2300</td> </tr> </table>	C1	5 - 68 y/and/et 125 - 862	C2	88 - 108	C3	950 - 2300
C1	5 - 68 y/and/et 125 - 862							
C2	88 - 108							
C3	950 - 2300							
Atenuación de conexión Transfer loss Atténuation de connexion	dB	<table border="1"> <tr> <td>TV</td> <td>≤ 2</td> </tr> <tr> <td>RD</td> <td>≤ 2</td> </tr> <tr> <td>SAT</td> <td>≤ 3</td> </tr> </table>	TV	≤ 2	RD	≤ 2	SAT	≤ 3
TV	≤ 2							
RD	≤ 2							
SAT	≤ 3							
Desacoplo TV-RD y TV-SAT TV-RD and TV-SAT isolation Découplage TV-RD et TV-SAT	dB	> 18						
Desacoplo SAT y RD SAT and RD isolation Découplage SAT et RD	dB	> 18						
Paso de corriente (C3) DC transit (C3) Passage de courant (C3)	dB	Sí Yes Oui						
Placa embellecedora + Zócalo Coverplate + Frame Plastron + Socle		Sí Yes Oui						
Unidades / Embalaje Units / Packaging Unités / Emballage		1 / 58						
Peso embalado Packed weight Poids emballé	kg	1 ud 58 uds 0,170 / 9,8						
Dimensiones embalaje Packing dimensions Dimensions d'emballage	mm	1 ud 58 uds 48 x 80 x 80 / 400 x 29,5 x 24,5						

### Ejemplos de instalación Installation examples Exemples d'installation

